



Nutan Bidyut (Bangladesh)  
Limited (NBBL)

# Environment and Social Impact Assessment Report (ESIA) Addendum – Change in Design (CID) of Bhola 225MW Combined Cycle Power Project

28 January 2020

Project No.: 0518816

Document details	
Document title	Environment & Social Impact Assessment Addendum - Change in Design (CID) of Bhola 225MW Combined Cycle Power Project
Document subtitle	Final Report
Project No.	0518816
Date	28 January 2020
Version	0
Author	
Client Name	Nutan Bidyut Bangladesh Limited (NBBL)

#### Document history

Version	Revision	Author	Reviewed by	ERM approval to issue		Comments
				Name	Date	
Final	00	Salil Das Subhradeb Pramanik Dwaipayan Dutta	Debanjan Bandyopadhyay Rutuja Tendolkar	Debanjan Bandyopadhyay	28.01.20	Text

---


Signature Page

28 January 2020

# Environment & Social Impact Assessment (ESIA) Addendum – Change in Design (CID) of Bhola 225MW Combined Cycle Power Project

Final Report

---



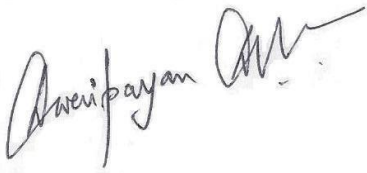
Salil Das  
Principal Consultant

---



Subhradeb Pramanik  
Principal Consultant

---



Dwaipayan Dutta  
Consultant

---



Debanjan Bandyopadhyay  
Partner

## ERM India Private Limited

Building 10A

4th Floor, DLF Cyber City

Gurgaon, NCR – 122002

Tel: 91 124 417 0300

© Copyright 2020 by ERM Worldwide Group Ltd and / or its affiliates ("ERM").  
All rights reserved. No part of this work may be reproduced or transmitted in any form,  
or by any means, without the prior written permission of ERM

## CONTENTS

<b>1.</b>	<b>INTRODUCTION .....</b>	<b>5</b>
1.1	Project Background .....	5
1.1.1	Revision of the Bulk HSD Storage Location.....	5
1.1.2	Construction & Operation of Temporary Gas Pipeline & RMS .....	9
1.1.3	Decommissioning of Temporary Jetty .....	12
1.1.4	Additional Environmental & Social (E&S) Studies .....	12
1.2	Project Location .....	13
1.3	Purpose and Scope of the Study .....	15
1.3.1	Purpose of the Study .....	15
1.3.2	Scope of ESIA Studies.....	15
1.4	Approach and Methodology .....	16
1.4.1	Addendum Study on E&S Implications of CID .....	16
1.4.2	Updating of the ESMP .....	17
1.5	Limitations.....	17
1.6	Structure of the Report .....	18
<b>2.</b>	<b>PROJECT DESCRIPTION &amp; CONTEXT .....</b>	<b>19</b>
2.1	Project.....	19
2.2	Plant Configuration .....	19
2.2.1	Power Block.....	19
2.2.2	Balance of Plant (BOP) system .....	19
2.3	Land Footprint.....	21
2.3.1	Original Plant Layout.....	21
2.3.2	Modified Plant Layout .....	21
2.3.3	Land Procurement Details .....	22
2.3.4	Additional Land Procurement Process and Compensation.....	22
2.4	Execution of the Project.....	24
2.4.1	EPC Contractor.....	24
<b>3.</b>	<b>BASELINE ENVIRONMENT (ADDITIONAL) .....</b>	<b>25</b>
3.1	Site Land Use .....	25
3.2	Sediment Quality .....	26
3.2.1	Interpretation of Monitoring Results .....	26
3.3	Fisheries .....	30
3.3.1	Fish Diversity .....	30
3.3.2	Protected Fish Species .....	30
3.3.3	Fish Catch Assessment .....	30
3.3.4	Socioeconomic Study: Fishermen Community.....	31
<b>4.</b>	<b>IMPACT ASSESSMENT &amp; MITIGATION MEASURES.....</b>	<b>33</b>
4.1	Introduction .....	33
4.2	Impact Assessment Methodology and Approach.....	33
4.2.1	Prediction of Impacts .....	34
4.2.2	Evaluation of Impacts.....	34
4.2.3	Identification of Mitigation and Enhancement Measures.....	38
4.2.4	Residual Impact Evaluation .....	38
4.3	Potential Impact on Land Use due to procurement of Additional Land .....	39
4.4	Potential Impact on Soil & Sediment Quality.....	40
4.5	Impact on Surface Water Quality due to Thermal Discharge .....	42
4.6	Impact on Surface Water Quality and aquatic ecology due Accidental Oil Spill in the River.....	45
4.7	Impact on Community Health & Safety Due charge of HSD Storage area and Temporary Natural Gas (NG) supply Arrangement .....	49

4.8	Impact on Livelihood due to Land Procurement.....	50
<b>5.</b>	<b>RISK ASSESSMENT.....</b>	<b>53</b>
5.1	RA Study Objective.....	53
5.2	RA Methodology .....	53
5.3	Safety Measures for Proposed Flammable Storages & Pipeline .....	54
5.4	Hazard Identification .....	55
5.4.1	Hazards from Flammable Liquid Storages and Gas Pipelines .....	55
5.5	Frequency Analysis .....	56
5.5.1	Frequency Analysis – Diesel Storage .....	57
5.5.2	Frequency Analysis – Pipeline .....	59
5.6	Consequence Analysis .....	63
5.6.1	Consequence Analysis – Tankages.....	64
5.6.2	Consequence Analysis – Pipelines .....	69
5.7	Additional Mitigation Measures for CID.....	75
<b>6.</b>	<b>STAKEHOLDER CONSULTATION AND PARTICIPATION.....</b>	<b>76</b>
6.1	Introduction .....	76
6.2	Stakeholder Mapping and Analysis.....	76
6.3	Stakeholder Consultation for Additional Land .....	77
<b>7.</b>	<b>ADDENDUM ENVIRONMENTAL AND SOCIAL MANAGEMENT PLAN.....</b>	<b>82</b>
7.1	Introduction .....	82
7.2	Mitigation Measures.....	82
7.3	Environmental Management System .....	87
7.3.1	Commitments & Policies .....	87
7.3.2	ESMP Implementation, Roles and Responsibility .....	87
7.4	ESMP Monitoring & Audit .....	89
7.4.1	Introduction .....	89
7.4.2	Monitoring .....	89
7.4.3	Audit.....	89
7.4.4	Performance Indicators & Management Review .....	89
7.4.5	Reporting .....	92
7.4.6	Contractor Monitoring Reporting.....	92
7.4.7	Company Monitoring Reporting .....	92
7.4.8	Reporting Requirement.....	93
7.4.9	Training, Awareness and Competency .....	93
7.4.10	Stakeholder Engagement .....	93
7.5	ESMP Budget .....	94

## List of Tables

Table 2.1	Break-up of Land Requirement & procurement details.....	22
Table 2.2	Additional (Total) Compensation Amount Paid to PAPs.....	23
Table 3.1	Sediment Quality Monitoring Results.....	26
Table 3.2	Catch per Unit Effort (CPUE)-during Study Period.....	31
Table 3.3	Fish Captured Per Day from Kutuba Canal.....	32
Table 4.1	Impact Prediction Criteria.....	35
Table 4.2	Assessing Magnitude of Impact.....	35
Table 4.3	Sensitivity/Importance/ Vulnerability Criteria.....	37
Table 4.4	Mixing Zone Dimensions Based on Plume Center-line for Each Scenario.....	43
Table 4.5	Oil Spill Release Scenarios and Potential Impact Zone.....	46
Table 5.1	Frequency Categories and Criteria.....	56
Table 5.2	Tank Failure Frequency.....	57
Table 5.3	Primary Gas Pipeline Failure Frequency.....	60
Table 5.4	Primary Failure Frequency based on Diameter Class (1970-2013).....	61
Table 5.5	Natural Gas Pipeline - Failure Frequency.....	61
Table 5.6	Temporary Natural Gas Pipeline –Jet Fire Probability.....	62
Table 5.7	Severity Categories and Criteria.....	63
Table 5.8	Risk Matrix.....	64
Table 5.9	Risk Criteria and Action Requirements.....	64
Table 5.10	Diesel Storage Tank – Risk Modelling Scenarios.....	65
Table 5.11	Temporary Gas Pipeline Risk Modelling Scenarios.....	71
Table 6.1	Stakeholders and Key Points Discussed.....	78
Table 7.1	Environmental and Ecological Management Plan of the Project.....	83
Table 7.2	ESMP Monitoring Programme.....	90
Table 7.3	SLNG Reporting Requirement.....	93
Table 7.4	ESMP Budget.....	94

## List of Figures

Figure 1.1	Site Layout Plan (Initial Plan).....	6
Figure 1.2	Site Layout Plan (Final Plan).....	7
Figure 1.3	Final PlantLayout Plan –showing the Modification.....	8
Figure 1.4	Proposed Pipeline Route Map.....	10
Figure 1.5	Temporary Gasline and RMS.....	11
Figure 1.5	Plant Location Map.....	14
Figure 3.1	Historical Images of Land Cover of the Project Site.....	25
Figure 3.2	Sediment Oxygen Demand in Monitoring Locations.....	27
Figure 3.3	Total Organic Carbon in Monitoring Locations.....	28
Figure 3.4	Loss on Ignition in Monitoring Locations.....	29
Figure 4.1	Impact Assessment Process.....	34
Figure 4.2	Assessing Significance of Impact due to Proposed Project Related Activities.....	37
Figure 4.3	Thermal Plume for the Worst Case Downstream Scenario (Scenario 2).....	44
Figure 4.4	Oil Spill Trajectory Scenarios.....	47
Figure 5.1	Risk Assessment Methodology.....	54
Figure 5.2	Event Tree Analysis - Tank Failure.....	59
Figure 5.3	Gas Pipeline Failure – Distribution of Incident & Causes.....	60
Figure 5.4	Threat Zone Plot –50mm leak.....	66
Figure 5.5	Threat Zone Plot –100mm leak.....	67
Figure 5.6	Threat Zone Plot –300 mm leak (Worst Case).....	68
Figure 5.7	Natural Gas Release – Potential Consequences.....	71

Figure 5.8	Threat Zone Plot – Temporary Gas Pipeline Leak (25mm dia) .....	72
Figure 5.9	Threat Zone Plot – Temporary Gas Pipeline Leak (50mm dia) .....	73
Figure 5.10	Threat Zone Plot – Temporary Gas Pipeline Rupture.....	74
Figure 6.1	Photographs of Stakeholder Consultation .....	76
Figure 7.1	Organogram Structure of NBBL for Construction and Operation Phase of the Project.	88

### List of Appendix

<b>APPENDIX A</b>	<b>SEDIMENT QUALITY MONITORING REPORT</b>
<b>APPENDIX B</b>	<b>FISHERY STUDY REPORT</b>
<b>APPENDIX C</b>	<b>THERMAL DISCHARGE MODELLING REPORT</b>
<b>APPENDIX D</b>	<b>OIL SPILL RESPONSE PLAN</b>
<b>APPENDIX E</b>	<b>LRDP</b>
<b>APPENDIX F</b>	<b>EHS POLICY</b>

## 1. INTRODUCTION

### 1.1 Project Background

Shapoorji Pallonji Infrastructure Capital Company Private Ltd (SPICCPPL), India submitted a proposal to Government of Bangladesh (GOB) on Build-Own-Operate (BOO) basis for a dual fuel combined cycle power plant (CCPP) of capacity 220 MW (Gas) / 212 MW (HSD) to be located at Bhola island in Barisal division of Bangladesh.

GOB represented by Ministry of Power, Energy and Mineral Resources (MPEMR) approved SPICCPPL, as the 'Project Sponsor', on 31 March 2016 under the Quick Enhancement of Power and Energy Supply (Special Provision) Act 2010 (amended 2015) to implement the Project. Consequently, Bangladesh Power Development Board (BPDB) issued a Letter of Intent (LOI) dated 18 April 2016 to SPICCPPL to form a Company which shall be a Special Purpose Vehicle (SPV) with 100% shareholding by SPICCPPL. Nutan Bidyut Bangladesh Limited (NBBL), a SPV Company was formed to set up an Independent Power Plant (IPP) in Bhola District of Barisal Division, Bangladesh.

Environmental & Social Impact Assessment (ESIA) study was submitted for the project in March 2017 by ERM India Pvt. Limited. NBBL had submitted the ESIA report to Department of Environment (DOE), Govt. of Bangladesh for approval of EIA. The same was approved by DOE and project has received Environment Clearance (EC); dated January 31 2018. Subsequently, ESIA was updated in Jan. 2018 to incorporate AIIB Safeguard Standards.

Present report covers the potential environmental, health, safety and social impacts associated with changes in the project layout and Gas Pipeline.

#### 1.1.1 Revision of the Bulk HSD Storage Location

As per ESIA report (March 2017), the land requirement for the Project was estimated to be approximately 22.78 acres. The component wise land requirement is (i) main plant – 11.5 acres; (ii) additional land for laydown area & site access road- 5.78 acres and (iii) ROW for gas pipeline 4.64 acres. It was informed by NBBL that approximately 12.89 acres of land was already earmarked by Bangladesh Power Development Board (BPDB) for the project and same was handed over to NBBL after execution of Land Lease Agreement. NBBL has purchased additional 17.5 acres of land for the project. The socio-economic impact for procurement of additional land was assessed in the ESIA report submitted in Jan. 2018.

As per original site layout plan, HSD storage facility was located in Main plant Area (demarcated as main power plant site). In the revised site layout, HSD storage facility has been shifted to additional land procured for the project. However, storage capacity will remain same. The risk assessment and potential impact zone need to be re-assessed for shifting of HSD storage facility.

The Initial site layout plan has been presented in **Figure 1.1**. The Final Layout plan has been presented in **Figure 1.2**. The Final Layout Plan with showing the modification has been presented in **Figure 1.3**.



Figure 1.1 Site Layout Plan (Initial Plan)

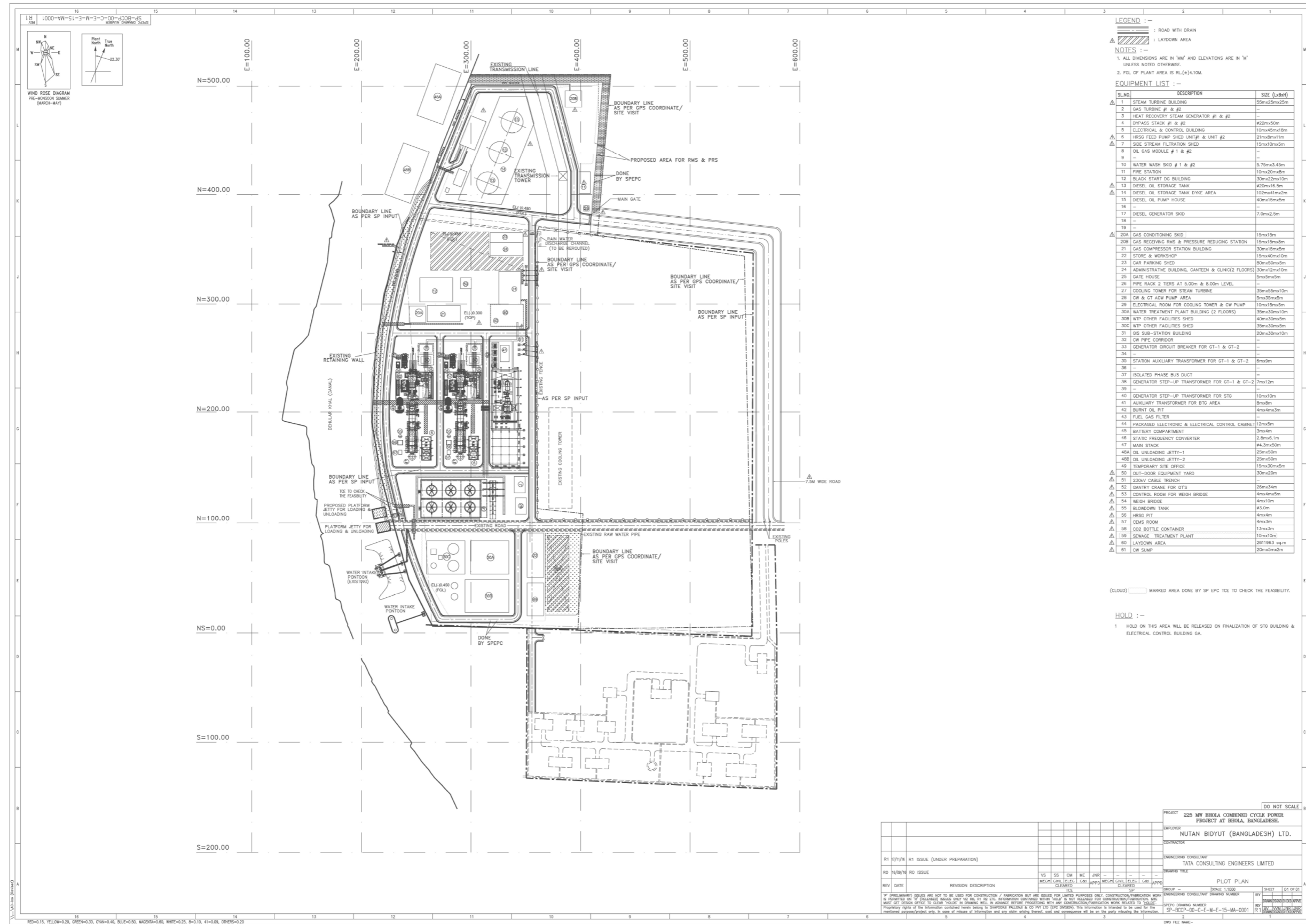
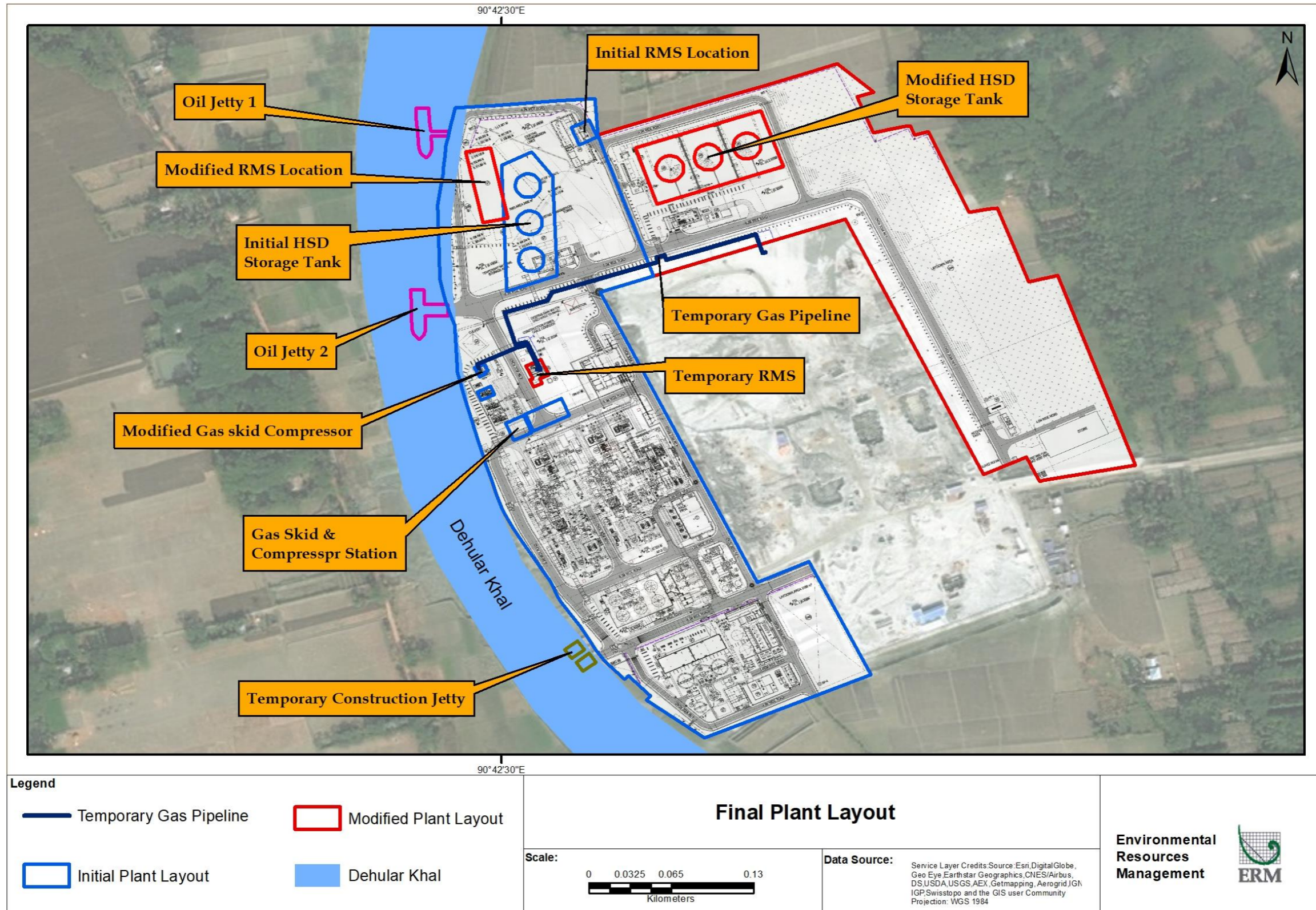


Figure 1.2 Site Layout Plan (Final Plan)



Figure 1.3 Final PlantLayout Plan –showing the Modification



### 1.1.2 Construction & Operation of Temporary Gas Pipeline & RMS

As discussed in the ESIA report dated March 2017, the natural gas for the plant will be sourced from Shabazpur Gas field, which is located at a distance of 6.70 km from the project site. The Gas will be supplied by Sundarban Gas Company Ltd. (SGCL) (a company of Petrobangla). SGCL is responsible for laying of the gas pipeline for the project. Land required for RoW, measuring 4.64 acres will be procured by SGCL. A Regulating and Metering Station (RMS) will be constructed inside the plant at North-East corner. The proposed pipeline route map has been presented in Figure 1.4. A Regulating and Metering Station (RMS) will be constructed inside the proposed plant at North-East corner. As per initial plant layout map, the RMS location was North-eastern side. The RMS in Final layout plan has been shifted to north-western side. The initial RMS location and final location has been presented in **Figure 1.3**.

NBBL has reported that, laying of gas pipeline will take approximately 12 months for completion and expected to be completed by Nov/Dec 2020. Hence as an interim arrangement, NBBL plans to lay a temporary gas pipeline of approximate 315 meters and RMS (Refer Figure 1.3) from BPDB's existing 225MW Combined Cycle Power Plant (CCPP) RMS off-take point to test, commission and operate the proposed NBBL Bhola Project. This temporary RMS and pipeline is scheduled to be completed by end of February 2020 with power project expected to be operational by March 2020. It may be further noted, that no additional land is required for laying and construction of this temporary gas supply infrastructure onsite. Details with respect to approval/permission for the aforesaid temporary gas supply arrangement including evaluation of potential risks and additional mitigation measures has been discussed under section 4.7 of this report. The temporary gas pipeline and RMS has been presented in Figure 1.3 and Figure 1.5.

Figure 1.4 Proposed Pipeline Route Map

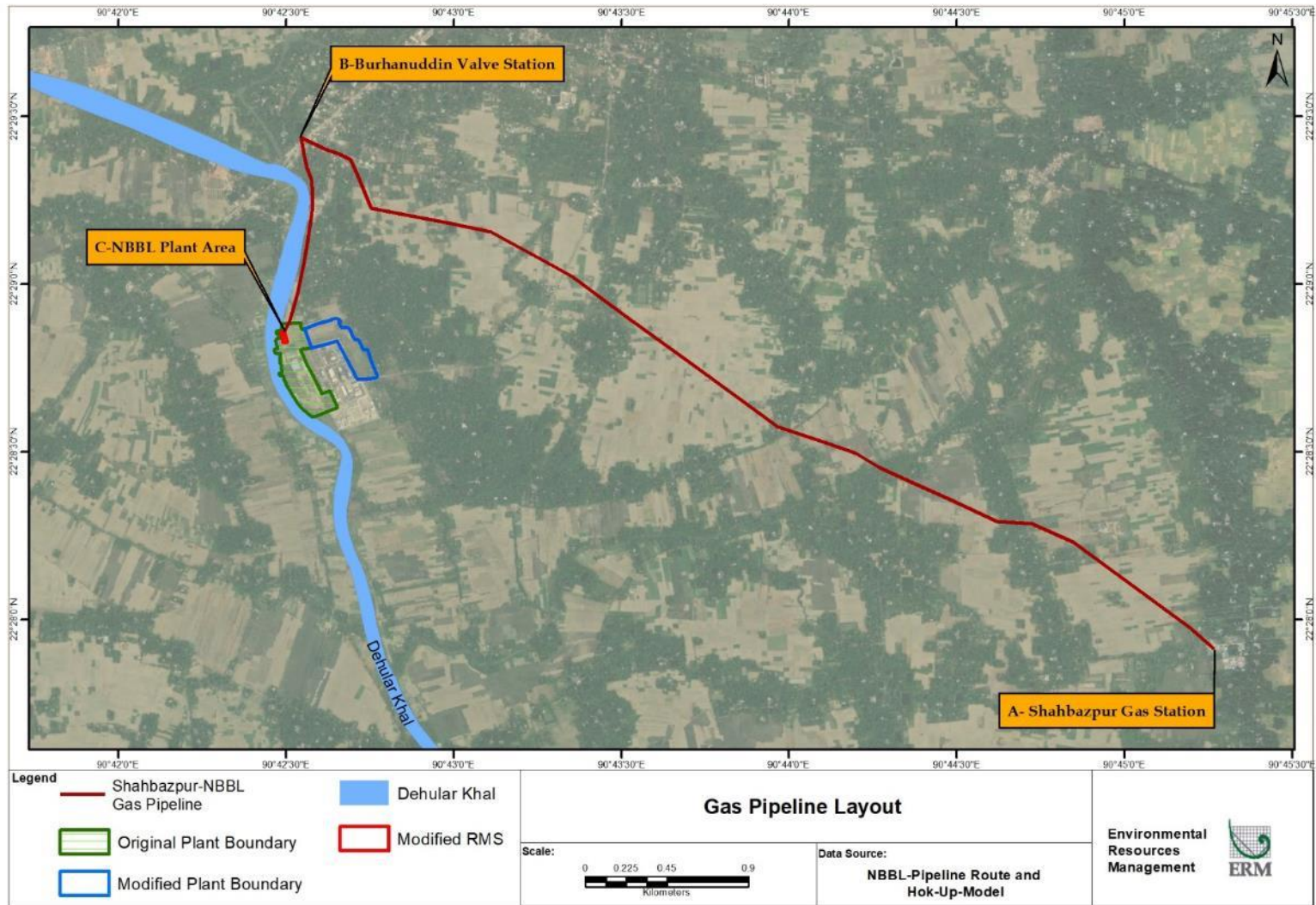
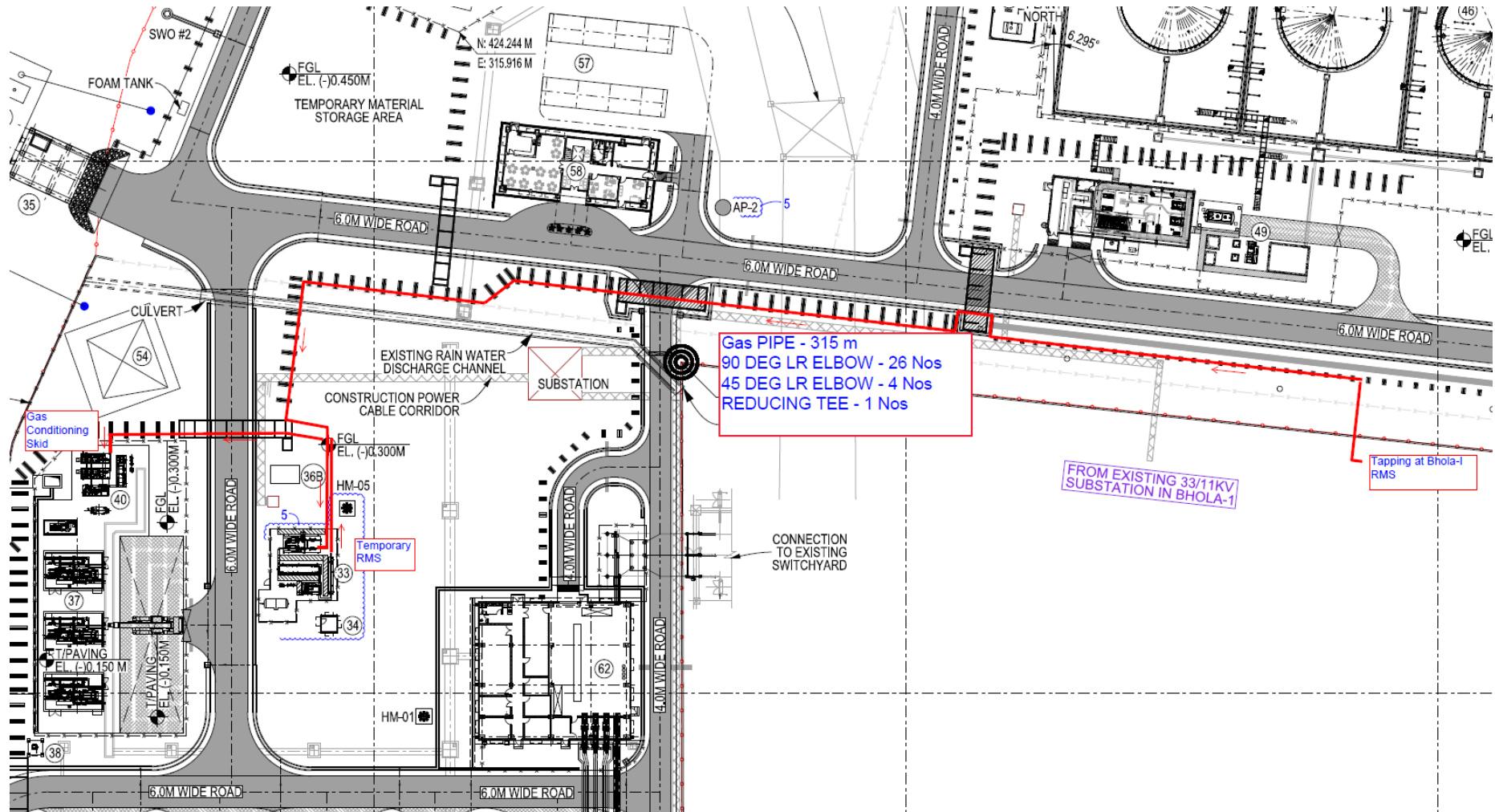


Figure 1.5 Temporary Gasline and RMS



### 1.1.3 Decommissioning of Temporary Jetty

NBBL has constructed a temporary jetty on Dehular Khal for transportation of construction materials, plants and equipment. This temporary jetty will be decommissioned after completion of construction work. The impact associated with decommissioning of jetty need to be assessed. The temporary construction jetty is located at southern side of the proposed plant (Refer Figure 1.3).

PI include Fig to show location of Temporary Jetty. Also provide details of size of jetty.

### 1.1.4 Additional Environmental & Social (E&S) Studies

NBBL has undertaken additional E&S studies based on the recommendation of the independent Environment & Social Advisor appointed for the project. This includes

- **Oil Spill Risk Assessment** - The Plant will operate on natural gas as its primary fuel and is designed to operate on HSD as alternate/back-up fuel. The HSD required for the plant will be delivered by Bangladesh Petroleum Corporation (BPC) on oil tankers to the jetty, which is being constructed on Dehular Khal. The oil spill modelling study has not been carried out in the EIA report. NBBL has carried out the oil spill modelling study under additional studies.
- **Thermal Plume Discharge Modelling** - The induced draft cooling tower system is provided for the proposed plant. Cooling tower blow down will be quenched and treated to meet environmental requirements before discharging to the Dehular Khal. Considering this, thermal plume modelling study has not been undertaken in the EIA study. However, NBBL has carried out the cumulative thermal plume modelling study for Bhola I and Bhola II CCGP under additional studies.
- **Sediment Sampling & Reporting** - The baseline sediment quality in Dehular Khal (2 locations-up stream and down-stream of on the proposed Bhola II) was assessed in the EIA report. The parameters like (i) Sediment Oxygen Demand (SOD); (ii) Total Organic Carbon (TOC); (iii) Loss on Ignition (LOI) and Total Petroleum Hydrocarbon (TPH) was not considered in the EIA study. NBBL has carried out sediment quality for SOD, TOC, LOI and TPH in five locations in three seasons (pre-monsoon, monsoon and post-monsoon) under additional studies.
- **Fishing Area Surveys** - The proposed Bhloa II CCGP is situated on the eastern bank of Dehular Khal, beside an existing 225 MW combined cycle gas based power plant of the BPDB. Dehular Khal is ultimately connected with Tetulia River (west) and Meghna River (east). Fish is an important resources in the project Area of Influence (AOI). To assess the impact of fish resources due to proposed project NBBL is now conducting quarterly fisheries studies in the AOI.
- **Climate Change Assessment for Flooding Risk**: The Bhola II of NBBL's plan is located at Kutba Union of Burhanuddin Upazilla in Bhola District. Hhola district is considered severely prone to flooding risk and climate change impacts, including land loss, soil erosion and ingress due to sea level rise. This increases the the risk of the area getting inundated over the coming decades due to ingress of raising sea levels. The site has been raised around 3.5 m to match the level with adjacent BPDP's Bhola I operational power plant. The current site level is around 4.3 AMSL. However, it remain unknown whether this finished level is higher than the high flood level (HFL) including impacts due to climate change I precipitation, storm surge and sea level rise due to climate change related events. Considering this NBBL has conduted Climate Change Assessment for Flooding Risk to proposed power plant project.

ERM India Pvt. Ltd (ERM) was appointed by NBBL to prepare an addendum to the earlier ESIA report to assess and evaluate the project design related changes with respect to E&S and propose additional mitigation measures, where appropriate. The addendum also includes review and update

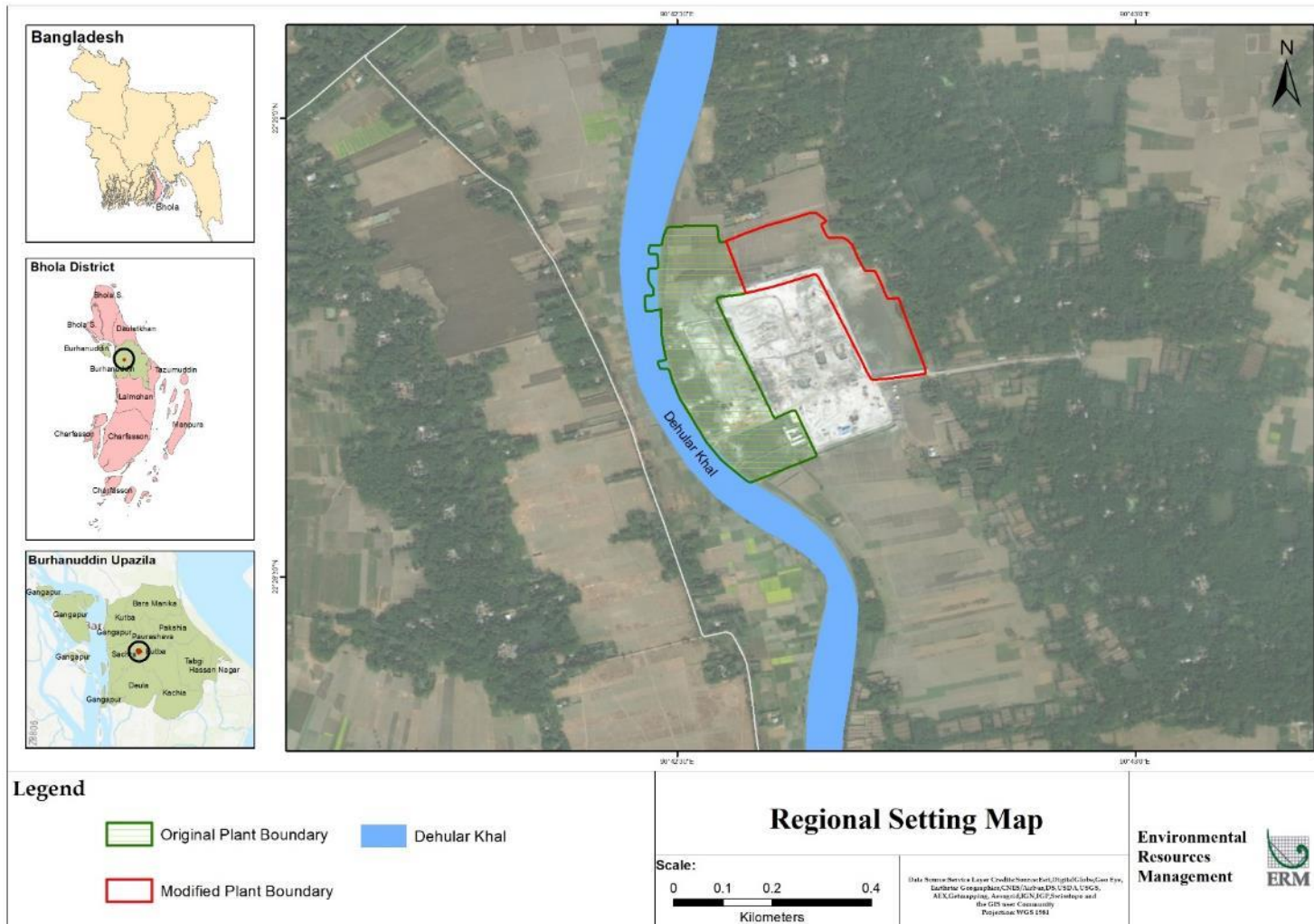
the existing Environmental & Social Management Plan (ESMP) resulting from the change in design (CID) and additional studies undertaken by NBBL in consistent with applicable national regulatory provision and international industry best practices.

## 1.2 Project Location

The Project site is located at Kutba Union of Burhanuddin Upazilla in Bhola District of Bangladesh. A location map of the project site is presented in *Error! Reference source not found.*. The project site is situated on the right bank of Dehular Khal, beside an existing 225 MW combined cycle gas based power plant of the BPDB. The nearest town is Burhanuddin, which is at a distance of 3 Km from the proposed project and Bhola District Headquarters is about 28 km north (road distance).



Figure 1.6 Plant Location Map



## 1.3 Purpose and Scope of the Study

### 1.3.1 Purpose of the Study

It is understood that NBBL has changed the initial layout of the plant related HSD storage facility and has planned temporary arrangement for sourcing gas from Bhola-I RMS. NBBL is planning to decommission construction jetty. Change in design also includes procurement of additional land. The project lenders have requested NBBL to assess and evaluate any potential environment and social impacts of the project resulting from the aforesaid changes and accordingly develop as addendum ESIA to January 2018 report.

In addition several other studies fisheries, land compensation audit oil spill management thermal plume modelling, cumulative impact assessment, High Flood Level Modelling, sediment monitoring) have been carried out. Hence, there is need to review, revise and update the Environmental and Social Management Plan (ESMP) of the proposed project.

### 1.3.2 Scope of ESIA Studies

The scope of Addendum ESIA

- Review the Change in Design (CID) of the project particularly with respect to additional land requirement and procurement process, stakeholder/landowners likely to be affected, identification of any socio-economic, cultural sensitivities, if any in the purchased and abutting property etc.
- Identify and assess any potential additional E&S impacts resulting from the change in location of Gas RMS and HSD tankages and additional purchase of land. This shall include but not limited to the following:
  - Economic/livelihood losses through material impacts caused by restricting access to and use of natural resources, if any;
  - Livelihood losses through non-material impacts related to social, recreational, cultural, knowledge and educational values of the land/resource to be restricted, if any.
  - Impacts related to reduced access to any social services such as education or health services by prohibiting or limiting physical access to places where those services are delivered;
  - Disturbances to patterns of social relations and community cohesion;
  - Impacts on human health and safety including injuries or death considering proximity to socio-cultural sensitivities
- Identify, assess and evaluate the potential impacts of the jetty decommissioning with respect to following as may be applicable – disruption of fishing activity, disposal of wastes, impact of aquatic flora and faunal habitat etc and develop a management plan for the decommissioning activity.
- Revisit the quantitative risk assessment considering the revised location of the bulk HSD tankages and Gas RMS station.
- Review and update the ESMP and Disaster Management Plan (DMP) in order to mitigate any E&S impacts identified (owing to the project CID) in consistent with the national regulatory requirements and international best practices/standards/guidelines.
- **Provide recommendations on safety distances between storage tanks and sensitive receptors, stakeholder engagement on Emergency Response Plan catering to matters of, soil & groundwater monitoring requirements specific to the site conditions** (i.e. in elevation above receptors; backfill/soil composition, stability and permeability; monsoon v. dry season; etc.) (and if required suggest a supplementary Resettlement Action Plan);

The scope of Addendum ESMP

- Review and update the existing ESMP taking the project's current lifecycle and outcomes of studies commissioned since January 2018;

- Prepare stakeholder engagement material to engage with relevant parties on impacts and mitigation measures, and conduct relevant stakeholder engagement during the ESIA Addendum preparation along with a public consultation meeting on the revised ESMP.

## 1.4 Approach and Methodology

The approach and methodology for the study has been discussed in the following section.

### 1.4.1 Addendum Study on E&S Implications of CID

#### *Discussion with NBBL Team*

- To understand the Project, current status of the project
- Collation of relevant project documents and reports. ERM team had submitted the information checklist to NBBL for relevant information.

#### *Desk Based Documentation Review*

A desk based documentation review studies that have been carried out for the proposed project. This shall include but not limited to the following:

- Livelihood Restoration and Development Plan for 225 MW Dual Fuel (Gas and HSD based) Combined Cycle Power Plant – Bhola; January 11, 2020; AECOM India Private Limited
- Land Acquisition & Resettlement Plan, External Monitoring and Evaluation Report for Bhola II Combined Cycle Power Plant, Bhola, Bangladesh; January 15, 2020; AECOM India Private Limited
- 220 MW Dual Fuel Combined Cycle Power Plant Project, Bhola, Bangladesh; 4<sup>th</sup> Construction Monitoring Report; May 3 2019; Mott MacDonald
- Thermal Plume Modelling using CORMIX for NBBL's Bhola Combined Cycle Power Plant, January 2020; ERM India Pvt. Ltd.
- Oil Spill Response and Control Plan of 225MW Dual Fuel Combined Cycle Power Plant, Bhola District, Bangladesh; October 2019, ERM India Pvt. Ltd.
- Sediment Quality Monitoring Report, January 2020; ERM India Pvt. Ltd.
- Discharge/Fisheries Study for 225 MW Dual Fuel (Gas and HSD based) Combined Cycle Power Plant (Bhola-II): Burhanuddin, Bhola District, Bangladesh; December 2019, EQMS
- Climate Change Assessment for Flooding Risk: 225 MW Combined Cycle Power Plant, Bhola, Bangladesh; May 2019; ERM India Pvt. Ltd.
- Environmental and Social Impact Assessment of 225 MW Dual Fuel (Gas and HSD based) Combined Cycle Power Plant (Bhola II): Burhanuddin, Bhola District, Bangladesh; March 2017, ERM India Pvt. Ltd.
- Revised project layout plan vis-à-vis the previous layout;
- ESIA Report and ESMP;
- Quantitative Risk Assessment Study Report;
- On-site Emergency Plan for Operational Phase; Nutan Bidyut (Bangladesh) Ltd (NBBL)
- Copy of applicable permits/licenses/agreement particularly Explosives Storage License, Environmental Clearance, Gas Supply Agreement etc.
- Existing information on land, social impacts and the current status of land procurement for the additional 10 acres of land.

#### *Site Visit & Interviews*

ERM team site visit for stakeholder consultation for assessment of impact due to additional land procurement for the plant. ERM also visited the project site to understand the proposed facility planned in the main power plant site and additional land. Stakeholder consultation includes following stakeholders:

- Land sellers
- Sharecroppers and Agricultural labours
- NBBL

### *Preparation of E&S Impact Assessment of CID*

Following completion of above mentioned study, E&S implication assessment report has been prepared. This report identifies, assesses and evaluates the potential E&S impacts resulting from the change in location of Gas RMS and HSD tankages, additional purchase of land and jetty decommissioning.

#### **1.4.2 Updating of the ESMP**

The ESMP to mitigate any E&S impacts identified (owing to the project CID) is consistent with the national regulatory requirements and international best practices/standards/guidelines. The ESMP has also furnished recommendation on safe distances between storage tanks and sensitive receptors, stakeholder engagement on emergency response planning, environmental monitoring requirements including the E&S indicators that need to be periodically monitored to measure the effective implementation of the ESMP.

While updating the ESMP, ERM referred to the outcome of the following studies being undertaken since 2019:

- Thermal Plume Discharge Modelling;
- Oil Spill Risk Assessment & Response Planning;
- AECOM Land Audit Report (June 2019);
- Involuntary Resettlement Audit Report (June 2019);
- Fisheries Study Report (May 2019);
- Project CID - E&S Implications Assessment Report;
- Revised Quantitative Risk Assessment Report.

### **1.5 Limitations**

ERM would like to highlight the following limitations to this ESIA document:

The construction activities have been going on from August 2018 and same were noted to have continued during ERM team site visit. NBBL has provided the information related construction activities and mitigation measures adopted during this phase. The present ESIA considers the current project configuration along with information provided by NBBL for construction phase of the project.

#### *Uses of this Report*

The Client acknowledges that report provided by ERM in relation to the provision of Services is delivered to the Client solely for the Client's benefit. ERM, its officers, employees, contractors, and agents shall owe no duties, obligations or liabilities to any persons in connection with any use of or reliance on the Project information provided by NBBL. We make no warranties, express or implied, including without limitation, warranties as to merchantability or fitness for a particular purpose.

ERM is not engaged in social and environmental, health & safety consulting and reporting for the purposes of advertising, sales promotion, or endorsement of any client's interests, including raising investment capital or recommending investment decisions, or other publicity purposes. The client acknowledges that the report prepared by ERM are for exclusive use of the client and agrees that ERM's reports or correspondence will not be used or reproduced in full or in part for such promotional purposes, and may not be used or relied upon in any prospectus or offering circular. The client also agrees that none of its advertising, sales promotion, or other publicity matter containing any

information obtained from these assessments or reports, either in parts or entirety, will make reference to ERM's trade name.

Nothing contained in this report shall be construed as a warranty or affirmation by ERM that the site and property described in the report are suitable collateral for any loan or that acquisition of such property by any lender through foreclosure proceedings or otherwise will not expose the lender to potential environmental or social liability.

## 1.6 Structure of the Report

- Section 1: **Introduction** (present chapter)
- Section 2: **Project Description:** This chapter describes the Project elements, including descriptions of: existing facilities; and construction, commissioning and operational processes.
- Section 3: **Baseline Environment:** The additional baseline section includes change of land use, sediment quality, project affected families and fisheries.
- Section 4: **Environmental Impacts and Mitigation Measures.** This chapter presents the assessment of potential environmental impacts, including identification of mitigation measures.
- Section 5: **Stakeholder Consultation:** This section identifies the primary and the secondary stakeholders and describes the consultation mechanism that has been undertaken for procurement of additional land
- Section 6: **Environmental and Social Management Plan.** This chapter describes the approaches to environmental and social management that are adopted in order to ensure that environmental and social performance is managed in an integrated manner across all Project activities and throughout the life of the Project.

## 2. PROJECT DESCRIPTION & CONTEXT

### 2.1 Project

The Project consists of 2 Gas Turbine Generators, 2 Heat Recovery Steam Generators and 1 Steam Turbine Generator along with Balance of Plant with net generating capacity 220 MW (net) on gas and 212 MW (net) on HSD in combined cycle operation at reference site conditions

### 2.2 Plant Configuration

#### 2.2.1 Power Block

##### *Gas Turbine*

The gas turbine is of GE make, equipped with dual fuel (Gas/Fuel Oil) combustion system. The gas turbines will use low NOx combustor for gas fuel and do not require DM Water/ Steam injection for NOx control on gas. However, the gas turbines are equipped with DM water injection system for NOx control on Fuel Oil firing.

The gas turbine comprises multi-stage axial compressor section. The air intake system will receive, filter and direct the ambient air flow into the inlet of the compressor. The intake system will consist of filter house having weather hood, bird screen, weather louver, coalesce, pre-filter and fine filter. The gas turbine exhaust system will consist of the exhaust gas diffuser, which connects the gas turbine with bypass stack.

The gas turbine configuration and location is as per original plan.

##### *Heat Recovery Steam Generator*

The Heat Recovery Steam Generator (HRSG) is a dualpressure, unfired, natural circulation and horizontal type supplied by GE. The hot exhaust flue gas from gas turbine will flow to the HRSG which will extract heat energy from the flue gas to produce superheated steam which will run the steam turbine at rated output. The flue gas after HRSG will be led to atmosphere through main stack located at the end of HRSG.

The configuration and location of HRSG is as per original plan.

##### *Steam Turbine*

The steam turbine (ST) is 3000 RPM, non-reheat, condensing type, coupled directly to a two (2) pole cylindrical rotor, closed circuit, air cooled generator that delivers power at a voltage of 11 kV. The ST exhaust and condenser configuration will be in accordance to manufacturer's standard design. The ST is sized to pass the steam generated by the HRSG over the full range of ambient temperatures as specified.

The configuration and location of ST is as per original plan.

#### 2.2.2 Balance of Plant (BOP) system

Balance of Plant (BOP) system consists of Fuel Gas System, Fuel Oil System, Water and Waste Water Treatment System, Cooling Water System and Auxiliary Cooling Water System, Compressed Air System, Fire Protection System, etc.

##### *Natural Gas System*

The gas will be supplied from Shabajpur gas field of Sundarban Gas Company Limited. A pipe line approximately 6.7 km from Shabajpur gas field to the plant will be laid for this purpose by SGCL. As per original plan; the permanent Regulating and Metering Station (RMS) will be constructed inside of

the proposed plant at North-East corner. NBBL has reported that, laying of gas pipeline and installation of permanent RMS will take approximately one years (I.e. end 2020). An interim arrangement will be made for supply of gas from Bhola I power plant. Approximately 315 m pipeline will be constructed from Bhola I RMS to NBBL temporary RMS. The temporary RMS system has been presented in **Figure 1.5**.

As per Gas Supply agreement approx. 3500 sq. m area has to be provided for the installation of the permanent RMS system. Initially, NBBL has considered the space less than that (but sufficient for the skid and Control room). However, Sundarban Gas Company did not agree for the same proposal. So additional space is required to accommodate the Gas company requirement. The additional space has been provided in the modified site layout plan.

High Speed Diesel (HSD) as Fuel Oil is envisaged as alternate or back-up fuel to Natural gas. The power plant receives fuel oil from the Bangladesh Petroleum Corporation (BPC). Fuel oil is envisaged to be transported in the oil tankers to the power plant by barges through waterways. The fuel oil will be unloaded by unloading pumps from the tanker/barge and will be stored in storage tanks in the power plant. The storage capacity of HSD is  $3 \times 5400 \text{ m}^3$ .

In the original plot plan the location of HSD storage facility was on the north-eastern side of the proposed plant. In the initial Plot Plan, Fuel storage area was proposed and utilized the space optimally. However while carrying out the detailed Engineering activity, some of the HSD dyke area was falling under the overhead transmission lines safe distance zone. In view of this and also to accommodate Fuel Oil pump house, foam pump house and oil water separator, are relocated to new location.

As per modified plan the HSD storage tanks will be shifted in the additional procured land; i.e. towards, eastern side. The modified storage location has been presented in **Figure 1.3**. The oil unloading jetty will remain same as proposed in original plan.

### Water Systems

Water for a combined cycle plant is required for condenser cooling, cooling of various GTG/STG/HRSG auxiliaries, for plant service water, for potable water, fire water systems and for production of DM water for power cycle make-up and Injection Water for Gas Turbines (during liquid fuel operation). The total consumptive water requirement for the 220 MW (Net) CCPP is estimated to be  $345 \text{ m}^3/\text{hour}$ . Source of water for this plant is Dehular Khal (canal) flowing adjacent to the Site.

A pre-treatment plant will be installed to clarify the raw water & the clarified water will be used for Cooling Tower make-up, service water, potable water and input water to the DM Plant. The sludge from the water pre-treatment plant will be treated and disposed of suitably. Sludge rejection from clarifier will be sent to plant waste water treatment facility.

The water requirement for the plant, source of water and treatment system is per original plan.

### Cooling Water System

The main cooling water system will provide cooling water to the steam turbine condenser by means of cooling water pumps installed in the cooling water pump house. The induced draft cooling tower will be provided with the capacity for maximum heat rejection duty under all steam turbine operation conditions for the design conditions specified. The cooling tower shall have sufficient cells to allow for one cell to remain in standby under reference operating conditions.

The cooling tower will contain clarified water. A cooling tower chemical injection system will be provided to maintain the appropriate cooling tower chemistry. Cooling tower blow down will be quenched and treated to meet environmental requirements before being sent to the Dehular Khal. There is modification proposed in the cooling system.

### *Effluent Treatment Plant*

All the effluent from DM plant, HRSG blowdown, Cooling tower blowdown, STG building floor wash, oily waste from transformer yard will be collected in a water collection/settling tank and will be discharged after proper treatment in effluent treatment plant. Effluents will be collected at CMB, which will act as an equalization basin having at least four (4) hours detention period. Acid and alkali dosing facility is provided at CMB to maintain the pH, BOD and COD. Treated effluent from CMB/ Guard Pond will be either discharged to the local water body or will be used for plantation/ green areas.

No modification has been proposed in the modified plan.

### *Air System*

Compressed air plant will be provided to meet instrument and service air requirement of gas turbines, steam turbine, HRSGs and other plant utilities. The location of the air system will remain same as proposed in the original plan.

### *Fire Protection System*

For protection of the plant against fire, all plant will be protected by any one or a combination of the following systems:

- Hydrant system (also includes the required number of hydrant pumps electrical motor driven and diesel engine driven).
- Automatic high velocity and medium velocity sprinkler system.
- Portable and mobile chemical extinguishers.
- Inert gas system
- Fire detection and alarm system
- 1 Fire Tender

Clarified water as supplied to the plant will be used for fire-fighting purposes. Dedicated firewater storage of two hours' fire-fighting requirement will be maintained in the Clarified Water Reservoir itself for fire-fighting purpose. There no modification proposed in the fire protection system.

### *Power Evacuation*

Power will be evacuated through proposed gas insulated switchyard of the proposed plant to the existing 230kV air insulated switchyard and from there it will be evacuated to Barisal substation through existing 230 KV transmission line.

The original plant layout plan and modified plant layout plan has been presented in Figure 1.1 and Figure 1.2 respectively.

## **2.3 Land Footprint**

### **2.3.1 Original Plant Layout**

As per original plan, the land requirement for the Project was approximately 22.78 acres. The main plant area was 17.20 acre. Approximately 12.89 acres of land was leased from BPDB for the project. Additional 5.78 acres of land will be acquired for the project including the access road. Furthermore, about 5.5 acres of right of way (RoW) will be required for the gas pipeline.

### **2.3.2 Modified Plant Layout**

As per modified plan, the land requirement for the Project is approximately 35.29 acres. The main plant area was 18.67 acre. Jetty installation area is 0.28 acres, infrastructure installation area – 0.05 acre, laydown area -11.65 acre. In addition, 4.64 acres of land for right of way (RoW) for gas pipeline will be procured by SGCL.



### 2.3.3 Land Procurement Details

The land procurement details has been presented in following table.

**Table 2.1 Break-up of Land Requirement & procurement details**

S. No.	Project Area	Area (Acre)	Ownership Status	Remark
<b>A</b>	<b>Leased Land</b>			
A.1.	Main plant area	12.89	Bangladesh Power Development Board (BPDB)	Lease agreement is on yearly renewal basis
A.2.	Jetty area	0.28	Bangladesh Inland Waterway Transport Authority (BIWTA)	Lease agreement is on yearly renewal basis
A.3.	Infrastructure Installations area	0.05	BIWTA	Lease agreement is on yearly renewal basis
	<b>Total Leased Land</b>	<b>13.22</b>		
<b>B</b>	<b>Private land procured by NBBL</b>			
B.1	Main plant area	5.78	Private land owners of Chor Gazipur and South Chota Monika villages	NBBL has been purchased the land from 42 land owners from Chor Gazipur villagers and 24 land owners from Chota Monika villagers
B.2	Laydown Area	9.815	Private land owners of South Chota Monika village	NBBL has been purchased the land from 54 land owners from Chota Monika villagers
B.3	Laydown Area	1.53	Private land owners of South Chota Monika village	Bisho Infra Projects Limited <sup>1</sup> has been purchased the land from 6 land owners from Chota Monika villagers
B.4	Laydown Area	0.305	Private land owners of South Chota Monika village	NBBL will purchase the land
9	<b>Total Private land for Power plant and laydown area</b>	<b>17.43</b>		
C	Gas Pipeline ROW	4.64	Private land owners of Kachia, Chagla, Kutuba and South Choto Monika villages	Land is to be acquired from potentially 550 landowners for the 7km gas pipeline route by SGCL.
	<b>Total land for the project (A+B+C)</b>	<b>35.29</b>		

[Source: Involuntary Resettlement Audit for Bhola II Combined Cycle Power Plant, Bhola, Bangladesh; AECOM India Private Limited; June 2019].

### 2.3.4 Additional Land Procurement Process and Compensation

NBBL informed that, BPDB has acquired 32.84 acres of land for setting up of power plant. The BPDB has acquired the land in 2012. BPDB has set up Bhola I power plant on 19.95 acre of acquired land. BPDB has leased 12.89 acres of land to NBBL for Bhola II power plant (from its land bank under its IPP process for Bhola I).

<sup>1</sup> M/s Bisho Infra Projects Limited is the EPC Contractor for NBBL

- It was presumed that land sellers were reluctant to sell the land, as the land being the source of livelihood resulting in produce of two to three crops in a season and land being an asset which could have been probably transferred over generations.
- The initial land value assessment process was completed in December 2016. The Ward Commissioners acted as the land consolidators for the process of land acquisition.
- As informed by the affected titleholders during the site visit, the payment amount received after sale of land being lesser than the market value, the said amount as productive investment was not sufficient to purchase land in adjoining area in the village due to the prevailing higher cost of land.
- The compensation amount worked out for the lands to be procured for the project was based on BDT 15,000 per decimal (the calculation was only for the mainland area, where the original reimbursement amount calculated earlier was BDT 5000 – 7000 per decimal).
- The calculation was done sometimes in 2016, even though the total amount calculated was more than three times but by the time the procurement process had started, the land values had gone up, as a result another 5000 was added making it upto BDT 20,000 per decimal).
- This process was adopted for all land procured for NBBL and Bisho from 2016 to 2019 excluding the gas pipeline which is under the jurisdiction of District Commissioner's Office with the applicability of The Acquisition and Requisition of Immovable Property Act, 2017.
- It was reported by the land sellers that the Ward Commissioner informed the land sellers that the land procurement was for the power plant and the land is to be given to the authorities either through direct purchase at the rate of BDT 20,000 per decimal or otherwise land acquisition mediated through Deputy Commissioner will be initiated (as was in the case for BPDB's Bhola I). Given this, the land sellers speculated that the direct sale is more economically beneficial and less time consuming as compared to other option provided and hence the land sellers agreed to sell land at the decided rate. It was further mentioned that another reason for sale of land was due to the fact that the neighbouring land seller were selling their land and as such the land sellers did not have a choice but to also sell their land parcels.
- All land sellers confirmed that they received the compensation at BDT 20,000 per decimal, in cash from the Ward Commissioner directly, in the presence of Revenue Office Representative. No commission for sale of land, sale tax, and land registration was charged from the land sellers, reportedly.

#### Additional Compensation:

The action plan given in the Land Audit Report was strictly followed while carrying out the disbursement process of 130 PAPs. A budget of **BDT 41,009,819.49/-** was earmarked as compensation amount to be paid to PAPs against their land selling, payment against standing crops, trees & loss of livelihood.

**Table 2.2 Additional (Total) Compensation Amount Paid to PAPs**

Number of Seller	Total Land Sold (in Acres)	Total Payment as per Procured Land (in BDT)	Total Payment of Standing Crops (in BDT)	Total Payment of Loss of Livelihood (in BDT)	Total Payment
130	17.425 + 0.305	29,537,033	11,47,331.8	10,325,455.08	<b>41,009,819.49</b>

**Note:** Payment of disbursement amount is nearly complet. Only for one PAP, the additional payment for trees, standing crops and livelihood is pending.

Source: NBBL, Bisho Infra Projects Limited

## **2.4 Execution of the Project**

### **2.4.1 EPC Contractor**

The Project is being executed through the following three EPC Contracts by two EPC contractors, Global Infra FZCO and Bisho Infra:

- Offshore Supply Contract
- Onshore Works Contract
- Onshore Service Contract.

All three EPC Contracts have been executed on 21st September 2017. The Offshore Supply Contract has been awarded to Global Infra FZCO. Onshore Works Contract and Onshore Service Contract have been awarded to Bisho Infra Project Ltd. Scope of Global Infra, the offshore supply contract, is to procure and deliver equipment up to Bangladesh sea port, Mongla. The scope of Bisho Infra, the onshore contractor, is to deliver equipment from Mongla port to site and construct the plant.

### 3. BASELINE ENVIRONMENT (ADDITIONAL)

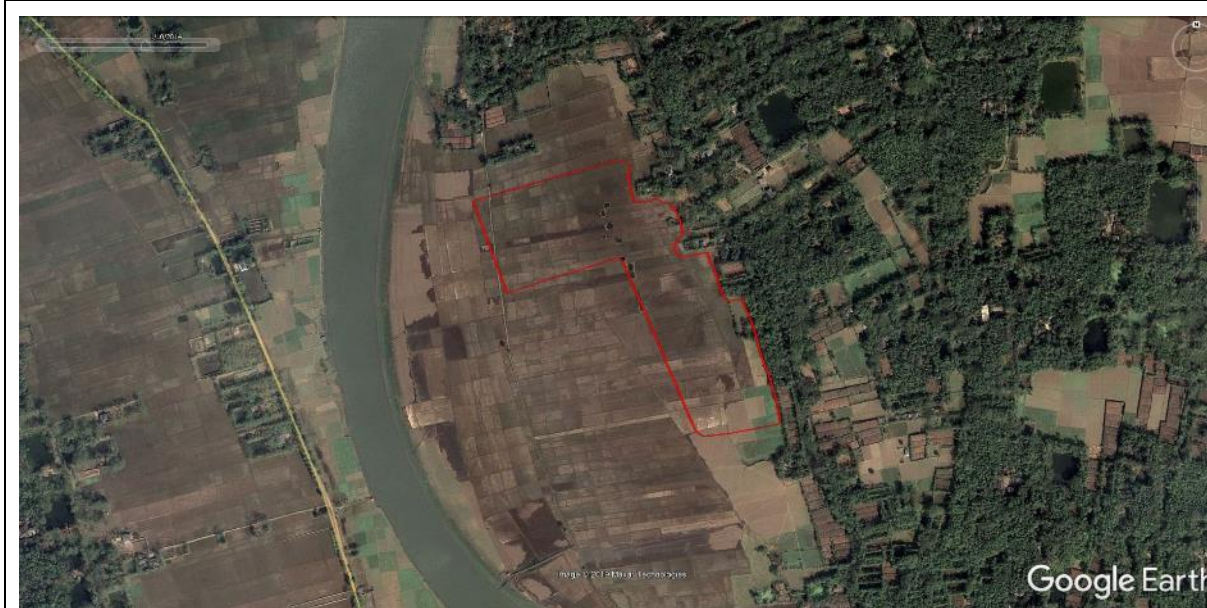
#### 3.1 Site Land Use

The total land required for Bhola II Power plant is 30.735 acres of land; additionally 4.64 acres of land is required for ROW of proposed gas pipeline. As discussed in section 2.3.3 of this report 13.22 acres of land has been taken on lease from BPDB and Bangladesh Inland Water Transport Authority (BIWTA). NBBL has procured 17.515 acres of private land for the power plant. As per land record, 17.515 acres of land is *Nall* land (agricultural land). In the original plant layout, 5.87 acres of agricultural land has been planned for the power project. Due to modification of plant layout, additional 11.645 acres of agricultural land has been procured for the project. The historical land use of the proposed project site reveals that NBBL procured land NBBL leased land was agricultural land. The historical satellite images of the project site has been presented in following **Figure 3.1**.

**Figure 3.1 Historical Images of Land Cover of the Project Site**



Land use and land cover of 2010



Land use and land cover of 2014



Land use and land cover of 2019

### 3.2 Sediment Quality

The baseline sediment quality in Dehular Khal (2 locations- up stream and down-stream of on the proposed Bhola II) was assessed in the ESIA report. The parameters like (i) Sediment Oxygen Demand (SOD); (ii) Total Organic Carbon (TOC); (iii) Loss on Ignition (LOI) and Total Petroleum Hydrocarbon (TPH) was not considered in the ESIA study. NBBL has carried out sediment quality for SOD, TOC, LOI and TPH in five locations in three seasons (pre-monsoon, monsoon and post-monsoon) under additional studies. The monitoring results of pre-monsoon, monsoon and post-monsoon seasons has been presented in below.

**Table 3.1 Sediment Quality Monitoring Results**

S. No.	Parameters	SD-1			SD-2			SD-3			SD-4			SD-5		
		PM	M	P	PM	M	P	PM	M	P	PM	M	P	PM	M	P
1	SOD (g/m <sup>2</sup> )	0.22	0.30	0.2	0.28	0.32	0.34	0.21	0.28	0.28	0.25	0.22	0.29	0.27	0.26	0.36
2	TOC (%)	0.29	0.43	0.23	0.12	0.50	0.40	0.47	0.44	0.30	0.21	0.36	0.34	0.51	0.50	0.45
3	LOI (%)	2.3	2.7	2.6	2.0	4.0	3.1	2.9	3.9	3.2	2.2	3.4	3.5	2.3	2.8	3.4
4	TPH (mg/kg)	<1.0	<1.0	<1.0	<1.0	<1.0	<1.0	<1.0	<1.0	<1.0	<1.0	<1.0	<1.0	<1.0	<1.0	<1.0

PM: Pre-Monsoon Season; M: Monsoon Season; P: Post Monsoon Season

The sediment quality monitoring reports has been provided in **Appendix A**.

#### 3.2.1 Interpretation of Monitoring Results

##### 3.2.1.1 Sediment Oxygen Demand

###### Pre-monsoon Season

The Sediment Oxygen Demand (SOD) ranged from 0.21 (SD-3) to 0.28 g/m<sup>2</sup> (SD-2) in the samples collected during pre-monsoon season. The higher SOD was recorded in SD-2 (0.28 g/m<sup>2</sup>) and SD-5 (0.27 g/m<sup>2</sup>) and can be attributed to presence of higher nutrients at these locations or because of higher intake of oxygen by the benthic organisms.

### Monsoon Season

The Sediment Oxygen Demand (SOD) ranged from 0.22 (SD-4) to 0.32 g/m<sup>2</sup> (SD-2) in the samples collected during monsoon season. The higher SOD was recorded in SD-2 (0.32 g/m<sup>2</sup>) and SD-1 (0.30 g/m<sup>2</sup>) and can be attributed to presence of higher nutrients at these locations or because of higher intake of oxygen by the benthic organisms.

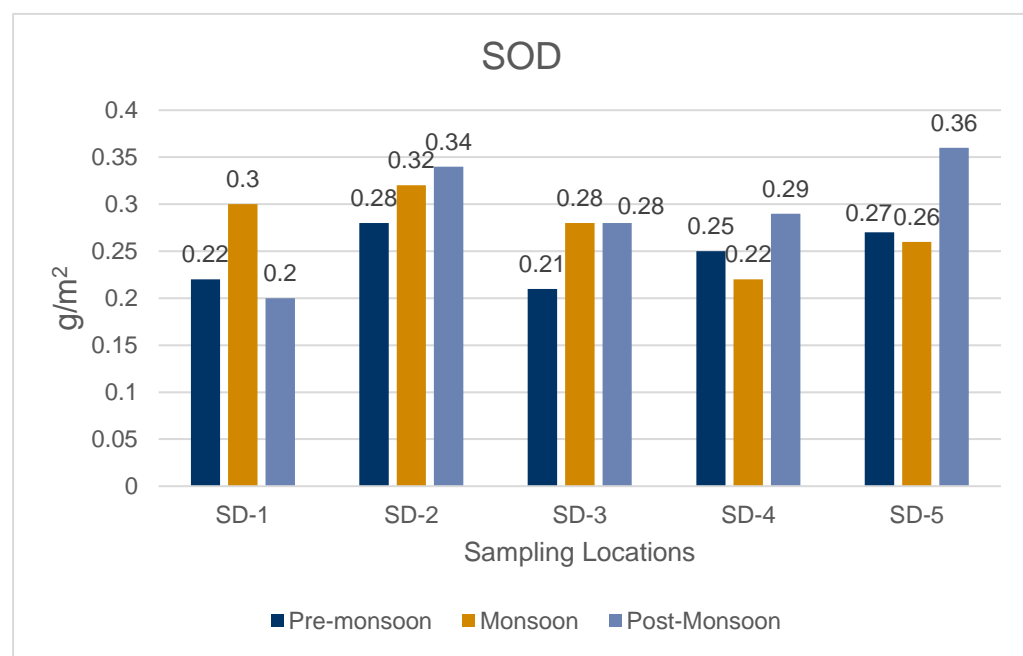
### Post Monsoon Season

The Sediment Oxygen Demand (SOD) ranged from 0.2 (SD-1) to 0.36 g/m<sup>2</sup> (SD-4) in the samples collected during post- monsoon season. The higher SOD was recorded in SD-4 (0.36 g/m<sup>2</sup>) and SD-2 (0.34 g/m<sup>2</sup>) and can be attributed to presence of higher nutrients at these locations or because of higher intake of oxygen by the benthic organisms.

It was observed that SOD values during monsoon season, in samples SD-1, SD-2 and SD-3 were increased whereas in samples SD-4 and SD-5 the values were decreased compared to pre-monsoon season. The higher values of SOD during monsoon season can be attributed to surface run-off with higher concentration of decomposable materials.

SOD values for SD-2, SD-4 and SD-5 samples show highest value in post-monsoon season compared to the 2 seasons. The higher concentration SOD during post-monsoon are due to low inflows of water during post-monsoon and low wind turbulence which reduces the chance of oxygen mixing through the water column (Terry et. al., 2016 ). All the sampling location except SD-1 shows higher or equal concentration SOD during post-monsoon season compared to monsoon season. The monitoring location wise SOD concentrations are presented in **Figure 3.2**.

**Figure 3.2 Sediment Oxygen Demand in Monitoring Locations**



#### 3.2.1.2 Total Organic Carbon

##### Pre Monsoon Season

The Total Organic Carbon (TOC) ranged from 0.12% (SD-2) to 0.51% (SD-5) for the samples collected during pre-monsoon. The influence of discharge from drainage channel near SD-5 and

BPDP Power Plant and NBBL construction site (SD-3) may have contributed to higher percentage of TOC in SD-5 (0.51% and SD-4 (0.47%). The other monitoring locations (SD-1, SD-2 and SD-4) have no direct discharge into the river and has been characterised by lower concentrations of TOC.

### Monsoon Season

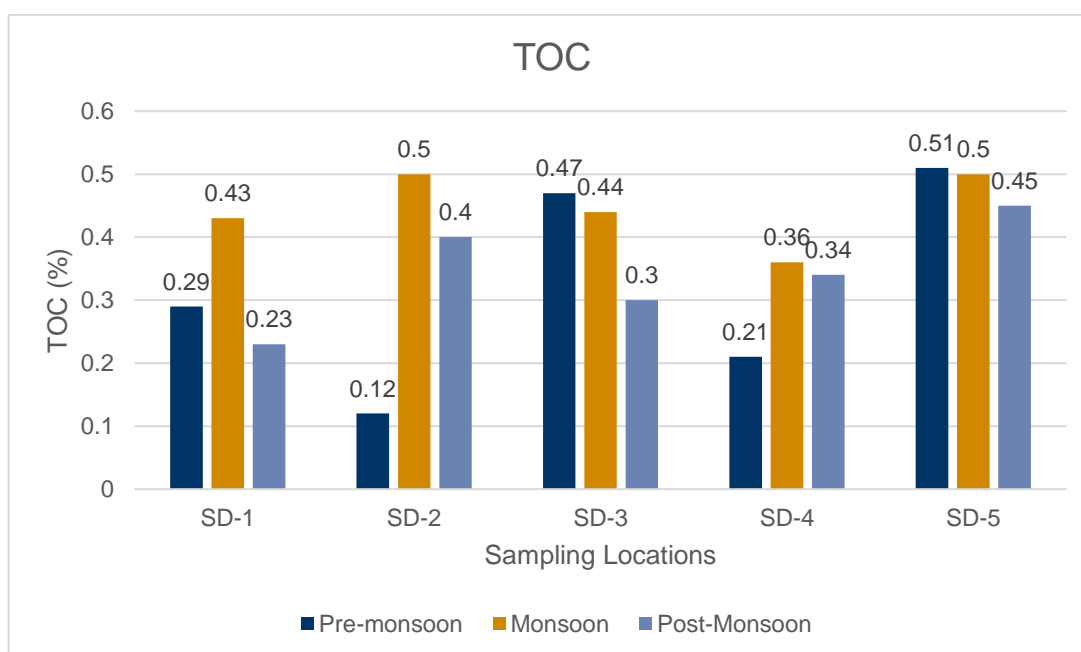
The Total Organic Carbon (TOC) ranged from 0.36% (SD-4) to 0.50% (SD-2 & SD-5) for the samples collected during monsoon. The highest value of TOC was observed at SD-4 and SD-5.

### Post Monsoon Season

The Total Organic Carbon (TOC) ranged from 0.23% (SD-1) to 0.45% (SD-5) for the samples collected during post monsoon. The highest value of TOC was observed at SD-5.

It was observed that TOC values during monsoon season, in samples SD-1, SD-2 and SD-4 were increased whereas in samples SD-3 and SD-5 the values were decreased compared to pre-monsoon season. The increased TOC values in SD-1, SD-2 and SD-3 are due to the surface run-off from nearby agricultural land. The discharge from drainage channel near SD-5 and BPDP Power Plant and NBBL construction site (SD-3) may be reason for high and almost similar TOC concentration in the area. TOC values of all the samples show lower values during post-monsoon season compared to monsoon season as a result of low inflow of water into the streams during post-monsoon season. The monitoring location wise TOC concentrations is presented in **Figure 3.3**.

**Figure 3.3 Total Organic Carbon in Monitoring Locations**



#### 3.2.1.3 Loss on Ignition

In sediments, there are three basic forms of carbon that may be present. They are: elemental C, inorganic C, and organic C. The quality of organic matter in sediments is critical to the partitioning and bioavailability of sediment-associated contaminants. The loss-on-ignition (LOI) method for the determination of organic matter involves the heated destruction of all organic matter in the sediment.

### Pre Monsoon Season

The Loss on Ignition (LOI) ranged from 2.0% (SD-2) to 2.9% (SD-3) for the samples collected during pre-monsoon; it indicates higher organic carbon is presence.

### Monsoon Season

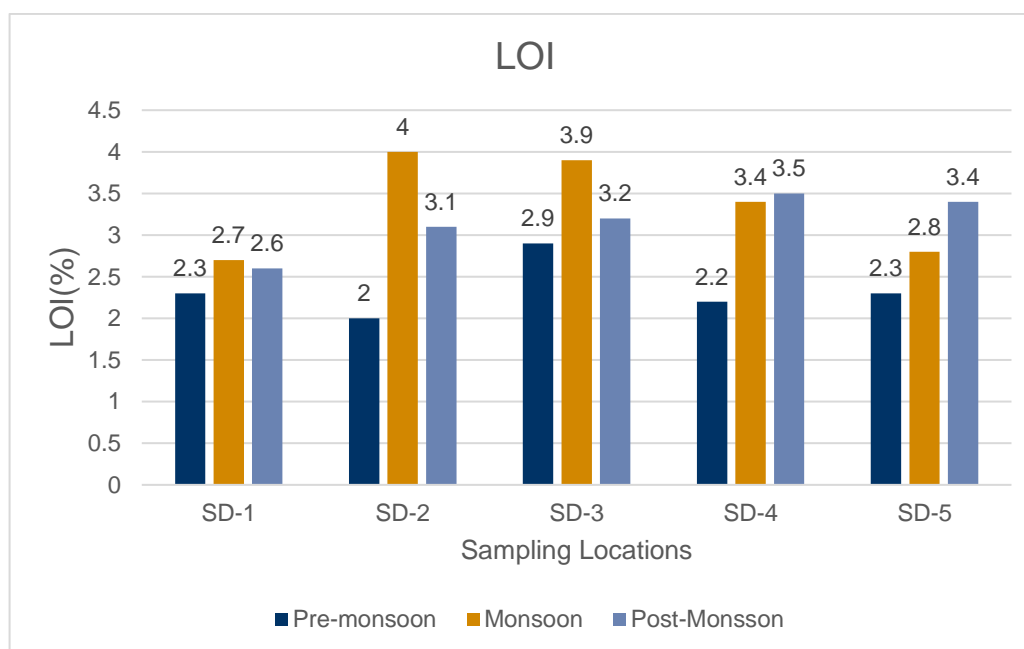
The loss-on-ignition (LOI) method for the determination of organic matter involves the heated destruction of all organic matter in the sediment. The Loss on Ignition (LOI) ranged from 2.7% (SD-1) to 4.0% (SD-2) for the samples collected during monsoon; it indicates higher organic carbon is presence.

### Post Monsoon Season

The loss-on-ignition (LOI) method for the determination of organic matter involves the heated destruction of all organic matter in the sediment. The Loss on Ignition (LOI) ranged from 2.6% (SD-1) to 3.5% (SD-4) for the samples collected during post monsoon; it indicates higher organic carbon is presence.

It was observed that LOI values in all samples during monsoon and post-monsoon season were increased compared to pre-monsoon season. It was observed that LOI values in SD-1, SD-2 and SD-3 during post-monsoon season were decreased compared to monsoon season while SD-4 and SD-5 values increased compared to monsoon season. The monitoring location wise LOI is presented in **Figure 3.4**.

**Figure 3.4 Loss on Ignition in Monitoring Locations**



#### 3.2.1.4 Total Petroleum Hydrocarbon

The Total Petroleum Hydrocarbon (TPH) in all the monitoring locations was found to be less than <1.0 mg/kg for pre-monsoon, monsoon and post-monsoon season. The monitoring results indicates that discharge sources in the study area has minimal or no presence of TPH.



### 3.3 Fisheries

NBBL has engaged EQMS Consulting Limited, Bangladesh for carrying out the fisheries study. The study area for fishery survey is 2 km radius area; which includes (i) 2 km upstream and downstream of Kutuba Canal (Dehular Khal) and ponds (2 ponds). Three season survey October (Autumn), January (winter), and April (Summer) will be conducted for this study. One season fishery study report (i.e. summer) has been available for review.

The key findings of fishery survey has been presented in the following section.

#### 3.3.1 Fish Diversity

##### 3.3.1.1 Kutuba Canal (Dehular Khal)

A total of seventy two (72) fish species were identified in the Kutuba Canal based on consultation with the fishermen, fishing ground analysis and fish market survey. The common fish species were Kavashi Tengra (*Mystus cavasius*), Lal Chewa (*Odontamblyopus rubicundus*), Gulsha/Nuna Tengra (*Mystus gulio*), Phasa (*Setipinna phasha*), Chapila (*Gudisia chapra*), Bacha (*Eutropiichthys vacha*), Poa (*Johnius argentatus*), Boal (*Wallago attu*), Shol (*Channa striata*), Magur (*Clarias batrachus*), Chapila (*Gudisia chapra*), Rui (*Labeo rohita*), Catla (*Catla catla*), Shing (*Heteropneustes fossilis*), Koral (*Lates calcarifer*), Pabda (*Ompok pabda*), Pangas (*Pangasius pangasius*) etc.

##### 3.3.1.2 Closed Water Aquaculture Pond

A total of twenty eight (28) fish species were identified in the ponds and canal based on consultation with the fishermen, fishing ground analysis and fish market survey. The common fish species were Bata (*Labeo bata*), Gulsha/Nuna Tengra (*Mystus gulio*), Jat-puti (*Puntius sophore*), Kalbasu (*Labeo kalbasu*), Koi (*Anabas testudineus*), Rui (*Labeo rohita*), Silver Carp (*Hypopophthalmichthys molitricus*), Tilapia (*Oreochromis niloticus*), etc.

#### 3.3.2 Protected Fish Species

Among 72 species, Pabda (*Ompok pabda*), Pangas (*Pangasius pangasius*), Rita (*Rita rita*), Gojar (*Channa marulius*), Chital (*Chitala chitala*), Gharua Bacha (*Clupisoma garua*), Shal Baim (*Mastacembalus armatus*) species are considered as Endangered (EN) whereas Chapila (*Gudisia chapra*), Bele (*Eugnathogobius oligactis*), Shil Biala (*Awaous grammepomus*), Pholi (*Notopterus notopterus*), Boal (*Wallgu Attu*), Air (*Sperata aor*), Guijja Ayre (*Sperata seenghala*), Kuchia (*Monopterus kuchia*), Baim (*Anguilla bengalensis*), are categorized as Vulnerable (VU) and Kavashi Tengra (*Mystus cavasius*), Gulsha/Nuna Tengra (*Mystus gulio*), Phulo chela (*Salmostoma phulo*), Tara Baim (*Macrogathus aculeatus*), and Shar Puti (*Systomus sarana*) species are listed as nearly threatened (NT) according to IUCN Red List of Bangladesh (2015)..

#### 3.3.3 Fish Catch Assessment

Fish catch assessment study was conducted to estimate the production of a particular waterbody. The Primary survey was done fortnightly. During the field visit, (December, 2018- November, 2019), a total of 28.199 kg of fishes were recorded from 102 efforts of Haul in Kutuba Canal. The fish catch was varied from 0 kg (5<sup>th</sup> Survey, 25<sup>th</sup> February to 28<sup>th</sup> February 2019) to 3.511 kg (20<sup>th</sup> Survey during 10<sup>th</sup> to 12<sup>th</sup> October).

##### 3.3.3.1 Catch per Unit Effort (CPUE)

In fisheries and conservation biology, the catch per unit effort (CPUE) is an indirect procedures of the abundance of species. Changes in the catch per unit effort are inferred to signify changes to the target species true abundance. A decreasing CPUE indicates overexploitation, while an unchanging CPUE indicates sustainable harvesting. The maximum weight of fishes Caught is 3.51 kg whereas the

average weight of fishes Caught during the whole study period is 1.22 kg. The average fish catch per haul is 0.26 kg or 260 grams.

**Table 3.2 Catch per Unit Effort (CPUE)-during Study Period**

Survey no.	Number of Haul	Total weight of fishes	CPUE
Survey 1	9	0.8 kg	0.089
Survey 2	7	2.1 kg	0.3
Survey 3	3	0.375 kg	0.125
Survey 4	6	0.95 kg	0.158
Survey 5	2	0 kg	0
Survey 6	2	0.72 kg	0.36
Survey 7	2	0.200 kg	0.100
Survey 8	4	1.200 kg	0.3
Survey 9	7	1.76 kg	0.25
Survey 10	3	1.600 kg	0.53
Survey 11	6	3.5 kg	0.58
Survey 12	3	0.200 kg	0.06
Survey 13	5	1.600 kg	0.32
Survey 14	5	2.38 kg	0.47
Survey 15	4	0.220 kg	0.05
Survey 16	4	0.725 kg	0.18
Survey 17	3	0.125 kg	0.04
Survey 18	5	0.945 kg	0.18
Survey 19	5	1.365 kg	0.27
Survey 20	6	3.511 kg	0.59
Survey 21	4	1.6 kg	0.40
Survey 22	3	0.957kg	0.32
Survey 23	4	1.286 kg	0.32

[Source: Fisheries Study for 225 MW Dual Fuel (Gas and HSD based) Combined Cycle Power Plant (Bhola-II): Burhanuddin, Bhola District, Bangladesh; EQMS Dec. 2019.]

### 3.3.4 Socioeconomic Study: Fishermen Community

During Fishery study period, team conducted Socio-economic Survey in the households of fishermen within the 2 km upstream and 2 km downstream of the power plant adjacent Kutuba Canal. The team surveyed 235 fishmen families. Among the total surveyed population, 86.4% are full-time and rest 13.6% are part-time fishermen who capture fishes in the Kutuba Canal and Tetulia River. The survey also reveals that 73.2% fishermen go to the Kutuba Canal for fishing. On the other hand, 26.8% fishermen go to both the Kutuba Canal and Tetulia River.

**Fish Captured Per Day from Kutuba Canal** The stakeholder consultations with fishermen and fish traders) were carried out during fishery study. On an average, fishermen captured fish 31.4 kg/day in 5 years ago but now they are capturing 7.4 kg/day. Five years ago, they captured fish minimum 4 kg/day and maximum 90 kg/day, but at present the amount is 0 kg and 35 kg/day respectively. It has been identified from the survey that the surveyed fishermen (235 person) used to capture fish 7376 kg/day, but at present the amount is 1742 kg/day.

**Table 3.3 Fish Captured Per Day from Kutuba Canal**

	5 Years Ago (kg)	Present (kg)
Mean	31.4	7.4
Minimum	4	0
Maximum	90	35
Sum	7376	1742

[Source: Fisheries Study for 225 MW Dual Fuel (Gas and HSD based) Combined Cycle Power Plant (Bhola-II): Burhanuddin, Bhola District, Bangladesh; EQMS Dec. 2019.]

#### 3.3.4.1 Monthly Gross Income from Fishing in Peak Season

Study finds that in the peak season, the monthly Gross Income of 6.8% of fishermen is equals or less than BDT 10,000. It also finds that the monthly Gross Incomes of 23.4%, 34.0%, 19.1% and 8.5% of fishermen are within the range of BDT 10001 – 20000, BDT 20001 – 30000, BDT 30001 – 40000 and BDT 40001 – 50000 respectively. On the contrary, the monthly Gross Income of 8.2% of fishermen is more than BDT 50000.

Fisheries Study Report has been attached in **Appendix B**.

## 4. IMPACT ASSESSMENT & MITIGATION MEASURES

### 4.1 Introduction

This section identifies and assesses the potential impacts on environment and socio-economic component due to proposed power plant project. As mentioned in *Section 2.4* construction activity I being carried out. The impacts due to the Project activities across different phases have been identified and assessed.

- a. Construction Phase including Residual Impact
- b. Operational Phase

Impacts are identified and predicted based on the analysis of the information collected from the following:

- Project information (as outlined in Section 2);
- Baseline information (as outlined in Section 3).

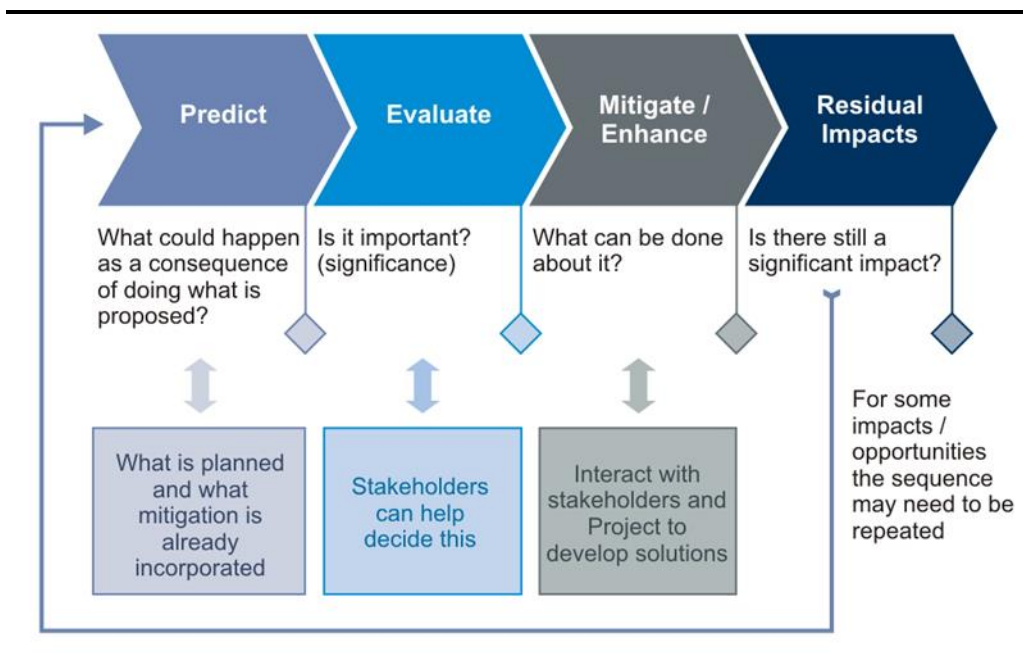
The impact assessment methodology; identification of potential impacts due to the proposed project related activities and their potential impacts have been worked out in the following sections.

### 4.2 Impact Assessment Methodology and Approach

Impact identification and assessment starts with scoping and continues throughout the remainder of the impact assessment process (IAP). The principal impact assessment (IA) steps are comprises of:

- **Impact identification:** based on the project activities and related aspects, potential impacts are identified. The impacts were identified based on interaction of proposed activities/aspects on various resources/receptors prevailing in critical habitat and fishermen livelihood components;
- **Impact prediction:** to determine what could potentially happen to resources/receptors as a consequence of the Project and its associated activities;
- **Impact evaluation:** to evaluate the significance of the predicted impacts by considering their magnitude and likelihood of occurrence, and the sensitivity, value and/or importance of the affected resource/receptor;
- **Mitigation and enhancement:** to identify appropriate and justified measures to mitigate negative impacts and enhance positive impacts;
- **Residual impact evaluation:** to evaluate the significance of impacts assuming effective implementation of mitigation and enhancement measures.

**Figure 4.1 Impact Assessment Process**



### 4.2.1 Prediction of Impacts

Prediction of impacts is essentially an objective exercise to determine what could potentially happen to the environment as a consequence of the project and its associated activities. This is essentially a repeat of the process undertaken during scoping, whereby the potential interactions between the Project and the baseline environment are identified. From these potential interactions, the potential impacts to the various resources/receptors are identified, and are elaborated to the extent possible. The diverse range of potential impacts considered in the IA process typically results in a wide range of prediction methods being used including quantitative, semi-quantitative and qualitative techniques. The nature and types of impacts that has been addressed in this EIA is defined below.

#### **Box 4.1 Nature & Types of Impacts Considered for Impact Assessment**

**Negative:** when impact is considered to represent adverse change from the baseline or introduced a new undesirable factor;

**Positive or beneficial:** when impact is considered to represent improvement to baseline or introduced a new desirable factor;

**Direct:** impacts that result from a direct interaction between the project and a resource/ receptor;

**Indirect:** impacts that follow on from the direct interactions between the project and its environment as a result of subsequent interactions within the environment; and

**Induced:** impacts that result from other activities (which are not part of the project) that happen as a consequence of the project.

### 4.2.2 Evaluation of Impacts

Evaluation of significance of an impact is assessed by ascertaining (a) magnitude and (b) sensitivity/vulnerability/importance of resource/receptor likely to be impacted as defined in the following description:

#### 4.2.2.1 Determining Magnitude of an Impact

Magnitude, i.e. severity of an impact or degree of change caused by a project activity is a function of interaction characteristics of Scale, Extent and Duration. The criteria that have been evolved for each of these key elements resulting in degree of change with corresponding ranking/level of impacts (low, medium and high) on the environmental component are presented in **Table 4.1**.

**Table 4.1 Impact Prediction Criteria**

Impact Elements	Criteria	Ranking
Scale: Degree of damage that may be caused to the environmental components concerned	<ul style="list-style-type: none"> <li>Irreversible damage to natural environment and/or likely difficult or may not to revert back to earlier stage with mitigation;</li> <li>Major changes in comparison to baseline conditions and / or likely to regularly or continually exceed the standard;</li> </ul>	High
	<ul style="list-style-type: none"> <li>Reversible damage to natural environment but likely to easily revert back to earlier stage with mitigation;</li> <li>Perceptible change from baseline conditions but well within acceptable norms.</li> </ul>	Medium
	<ul style="list-style-type: none"> <li>Effect is within the normal range of natural variation;</li> <li>No perceptible or readily measurable change from baseline conditions;</li> </ul>	Low
Extent: Spatial or geographical extent of impact due to a project and related activities	Project site and the entire study area i.e. beyond Project influence area (10.0 km from plant)	National
	Project site and its surroundings (5.0 km from proposed plant)	Regional
	Project site and its immediate vicinity (0.5 km from plant)	Local
Duration: Temporal scale of the impact in terms of how long it is expected to last	Spread beyond the lifecycle of the project	Long term
	Spread across several phases of the project lifecycle	Medium term
	Only during particular activities or phase of the project lifecycle	Short term

Magnitude essentially describes the intensity of the change that is predicted to occur in the resource/receptor as a result of the impact. The magnitude combines the impact characteristics of Extent, Duration and Scale and is a multiplicative factor of these three criteria set. Based on the above understanding magnitude of impact is assessed as per **Table 4.2**.

**Table 4.2 Assessing Magnitude of Impact**

Scale	Extent	Duration	Magnitude
Low	Local	Short Term	Negligible
Low	Regional	Short Term	Small
Low	Local	Medium term	
Medium	Local	Short Term	
Low	National	Short Term	

Scale	Extent	Duration	Magnitude
Low	Local	Long term	Small
High	Local	Short Term	
Low	Regional	Medium term	
Medium	Regional	Short Term	
Medium	Local	Medium term	
Low	National	Medium term	Medium
Medium	National	Short Term	
Low	Regional	Long term	
High	Regional	Short Term	
Medium	Local	Long term	
High	Local	Medium term	
Medium	Regional	Medium term	
Low	National	Long term	
High	National	Short Term	
High	Local	Long term	
Medium	National	Medium term	Large
Medium	Regional	Long term	
High	Regional	Medium term	
Medium	National	Long term	
High	National	Medium term	
High	Regional	Long term	
High	National	Long term	

#### 4.2.2.2 Determining Sensitivity/ Importance/ Vulnerability of Receptor

In addition to ascertaining magnitude of impact, the other principal step necessary to assign significance for an impact is to define the sensitivity/ vulnerability/ importance of the impacted resources/ receptor. There are a range of factors to be taken into account when defining the sensitivity/ vulnerability/ importance of the resource/ receptor, which may be physical, biological, cultural or human as per the following understanding:

- Where the resources/ receptor is biological or cultural (for example, sea turtle habitat and nesting site), its importance (for example local, regional or national importance) and its sensitivity to the specific type of impact are considered;
- Where the receptor is human, the vulnerability of the individual, community or wider societal group is considered.

Definition as defined in has been adopted to determine sensitivity/ importance/ vulnerability of environmental resources or receptor.

**Table 4.3 Sensitivity/Importance/ Vulnerability Criteria**

Sensitivity	Contributing Criteria
<b>High</b>	<ul style="list-style-type: none"> <li>■ Ecologically sensitive/ protected area, provides habitat for globally protected species;</li> <li>■ Profound or multiple levels of vulnerability that undermine the ability to adapt to changes brought by the project.</li> <li>■ Human receptors/ vulnerable community are located within the project footprint and directly affected by the project</li> <li>■ Resource exclusive for community use</li> </ul>
<b>Medium</b>	<ul style="list-style-type: none"> <li>■ Natural habitat provides habitat for wildlife, which are protected under National regulations;</li> <li>■ Some, but few areas of vulnerability; retaining an ability to at least in part adapt to change brought by the project.</li> <li>■ Human receptors/ vulnerable community are located adjacent the project site and likely to be affected by the project</li> <li>■ Alternative resource available with community</li> </ul>
<b>Low</b>	<ul style="list-style-type: none"> <li>■ Modified habitat provides habitat for common species;</li> <li>■ Minimal vulnerability; consequently with a high ability to adapt to changes brought by the Project and opportunities associated with it.</li> <li>■ Human receptors are located away and are not likely to be affected due to the project related activities</li> </ul>

#### 4.2.2.3 Evaluating Significance of Impacts

Based on interaction of magnitude of impact and sensitivity/ vulnerability/ importance of resource/ receptor likely to be impacted, the significance of impact is assigned for each impact using the matrix shown in **Figure 4.2**

**Figure 4.2 Assessing Significance of Impact due to Proposed Project Related Activities**

		Sensitivity /Vulnerability / Important Resource / Receptor		
		Low	Medium	High
Magnitude of Impact	Negligible	Negligible	Negligible	Negligible
	Small	Negligible	Minor	Moderate
	Medium	Minor	Moderate	Major
	Large	Moderate	Major	Major

The context of various impact significance ratings is defined in **Box 4.2**.



## Box 4.2 Context of Impact Significance

An impact of **negligible** significance is one where a resource/receptor (including people) will essentially not be affected in any way by a particular activity or the predicted effect is deemed to be 'imperceptible' or is indistinguishable from natural background variations.

An impact of **minor** significance is one where a resource/receptor will experience a noticeable effect, but the impact magnitude is sufficiently small (with or without mitigation) and/or the resource/receptor is of low sensitivity/ vulnerability/ importance. In either case, the magnitude should be well within applicable standards.

An impact of **moderate** significance has an impact magnitude that is within applicable standards, but falls somewhere in the range from a threshold below which the impact is minor, up to a level that might be just short of breaching a legal limit. Clearly, to design an activity so that its effects only just avoid breaking a law and/or cause a major impact is not best practice. The emphasis for moderate impacts is therefore on demonstrating that the impact has been reduced to a level that is as low as reasonably practicable (ALARP). This does not necessarily mean that impacts of moderate significance have to be reduced to minor, but that moderate impacts are being managed effectively and efficiently.

An impact of **major** significance is one where an accepted limit or standard may be exceeded, or large magnitude impacts occur to highly valued/sensitive resource/receptors. An aim of IA is to get to a position where the Project does not have any major residual impacts, certainly not ones that would endure into the long-term or extend over a large area. However, for some aspects there may be major residual impacts after all practicable mitigation options have been exhausted (i.e. ALARP has been applied). An example might be the visual impact of a facility. It is then the function of regulators and stakeholders to weigh such negative factors against the positive ones, such as employment, in coming to a decision on the Project.

### 4.2.3 Identification of Mitigation and Enhancement Measures

Once the significance of an impact is assessed, the next step is to evaluate what mitigation and enhancement measures are warranted. In this EIA, following Mitigation Hierarchy has been adopted:

- **Avoid or Reduce at Source:** avoiding or reducing at source through the design of the project;
- **Abate on Site:** add something to the design to abate the impact;
- **Abate at Receptor:** if an impact cannot be abated on-site then control measures can be implemented off-site;
- **Repair or Remedy:** some impacts involve unavoidable damage to a resource and these impacts can be addressed through repair, restoration or reinstatement measures;
- **Compensate in kind,** compensate through other means: where other mitigation approaches are not possible or fully effective, then compensation for loss, damage and disturbance might be appropriate.

The priority in mitigation is to first apply mitigation measures to the source of the impact (i.e., to avoid or reduce the magnitude of the impact from the associated Project activity), and then to address the resultant effect to the resource/receptor via abatement or compensatory measures or offsets (i.e., to reduce the significance of the effect once all reasonably practicable mitigations have been applied to reduce the impact magnitude).

### 4.2.4 Residual Impact Evaluation

Once mitigation and enhancement measures are declared, the next step in impact assessment process is to assign residual impact significance. This is essentially a repeat of the impact

assessment steps discussed above, considering the assumed implementation of the additional declared mitigation and enhancement measures.

### 4.3 Potential Impact on Land Use due to procurement of Additional Land

#### Source of Impact

- Additional land for power plant
- Land for pipeline ROW

#### Impact Assessment

As discussed in Section 2.3; the total land required for the project is 30.65 acres. Out of the total land 13.22 acres of land has been taken on lease from BPDB and BIWTA and remaining 17.43 acres of private land has been procured for the project. The land use study of the project site reveals that private land was 2-3 cropped agricultural land. With the setting up of power plant the agricultural land will be permanently converted into industrial land. Additionally, 4.64 acres of land will be procured for ROW of pipeline.

The land use/ land cover study of 10 km radius area reveals that, the predominant land use was homestead plantation & vegetation (33.27%) and agriculture land (31.65%). This is followed by river (20.40%), mudflat (11.23%). Other category land-use and land cover in the study area includes industry, settlement, brick-kiln, waterbody, road, etc (Refer ESIA Report). The conversion of agricultural land to industrial land (0.07% of the total agricultural land in 10 km radius study area) – is assessed **low** scale of impact. The duration of impact is **long term**, as up to life of the project. The extent of impact is assessed to be **local**, as it limited to project footprint like power plant, and pipeline corridor. The resource/ receptor sensitivity is assessed to be **medium**, as number of people in the union are depends on agricultural land for livelihood. The impact on land use is assessed to be **minor**.

Procure of agricultural land may have impact on livelihood of the project affected families, same has been discussed in SE impact section of the report.

#### Mitigation Measures

The mitigation measures to minimize the above mentioned impact include:

- Immediate restoration of land to its best achievable original state after completion of the buried pipeline laying activity, thus to merge it with the best achievable surrounding land use.
- Restrict the all the construction activity within the acquired land for plant

Impact	Land Use Impact due to acquisition of land for power plant, and pipeline ROU			
	Impact Nature	Negative	Positive	
Impact Type	Direct	Indirect		Induced
Impact Duration	Short Term	Medium Term		Long Term
Impact Extent	Local	Regional		National
Impact Scale	Low	Medium		High
Impact Magnitude	Negligible	Small	Medium	Large
Resource/ Receptor Sensitivity	Low	Medium		High
Impact Significance (Without Mitigations)	Negligible		Minor	Moderate
	Significance of impact is considered <b>Minor</b>			

Impact Magnitude (With Mitigations)	Negligible	Small	Medium	Large
Impact Significance (With Mitigations) i.e. Residual Impact	Significance of impact is considered <b>Minor</b>			

### *Residual Impact*

Considering the implementation of above mentioned mitigations measures, the significance of residual impact is assessed as **Minor**.

## 4.4 Potential Impact on Soil & Sediment Quality

### *Source of Impact*

- Surface runoff from construction site (additional area)
- Discharge of waste water from construction site
- Decommissioning of Construction jetty

### *Embedded control measures*

The embedded control measures are as follows:

#### Construction Phase

- Fuel, chemical and lubricant will be stored in paved storage areas.
- Construction waste (non-hazardous) will be utilised for filling of site;
- Hazardous wastes generated from the construction will be disposed through approved vendor.

### *Impact Assessment*

Soil & Sediment contamination due accidental spillage and surface runoff: Fuels, lubricant, paints, etc., would be stored at designated paved areas. Thus the contamination of soil and sediment can happen only due to accidental spillage of fuel, lubricants and paints from storage areas and during the transfer of fuels and chemicals; and discharge through surface runoff into nearby Dehular Khal. The contamination of fuel, lubricants, and paints may affect the sediment quality and benthos (micro-macro benthos) which lead to impact on fishes. The restoration of the contaminated sediment will be difficult and time taking activity.

Soil contamination from waste handling: Soil and may become contaminated due to improper handling and storage of waste (construction waste and jetty decommissioning wastes). The majority of the generated wastes will be non-hazardous. General construction waste will comprise of surplus or off-specification materials such as concrete, steel cuttings/filings, wooden planks, packaging paper or plastic, wood, plastic pipes, metals, etc. During the construction phase of the Project, solid waste generation will mainly be concrete waste and bitumen. The inert wastes will be stored in the laydown area. The hazardous wastes will be disposed off to licensed contractors. Domestic wastes consisting of food waste, plastic, glass, aluminium cans and waste packages will also be generated by the construction workforce.

The following hazardous wastes will be generated during construction phase:

- Used paint, engine oils, hydraulic fluids and waste fuel;
- Spent solvents from equipment cleaning activities; and
- Spent batteries or spent acid/alkali from the maintenance of machinery on site.

If improperly managed, hazardous waste may create impacts on land. The construction contractor will handle, store and dispose off all waste in accordance with applicable GOB guidelines. Concrete waste of inert nature will be stored near the concrete batching plant and will be reused. Any bitumen waste will be stored separately in lined areas to be disposed-off to licensed contractors. There is a potential for direct, long-term negative impacts to soil quality from improper waste handling.

*Decommissioning of Jetty:* The existing construction jetty is barge mounted with associated structures. The Decommissioning of jetty would generate the wastes like steel cuttings/filings, wooden planks. Improper handling of these waste may have impact on soil and sediment quality.

The contamination of fuel, lubricants, and paints may affect the soil microbes and bacterial growth, which leads change of soil/ sediment quality. The restoration of the contaminated soil/ sediment will be difficult and time taking activity.

Soil and sediment samples analysis indicates that the soil at the Project site is not contaminated. (*Refer EIA report and Section 3.2 of Addendum ESIA*). The potential impact on soil and sediment quality due to contamination– is assessed to be **low** scale of impact. The duration of impact is **medium term**, as restoration of the contaminated soil/ sediment will be difficult and time taking activity. The extent of impact is assessed to be **local** (for compaction and contamination), as it limited to project footprint like power plant. The resource/ receptor sensitivity is assessed to be **medium**, as project site and its surrounding is prime agricultural land and fish habitat. The impact on soil/ sediment quality is assessed to be **minor**.

### *Mitigation measures*

Potential impacts to soil and sediment during the construction phase are attributed to contamination from spills and leaks and wastes.

The following measures will be implemented for the storage and handling of chemicals and to minimise impacts to soil/sediment:

- Fuel tanks and chemical storage areas will be sited on sealed areas and provided with locks to prevent unauthorized entry;
- Use of spill or drip trays to contain spills and leaks;
- Use of spill control kits to contain and clean small spills and leaks.
- The storage areas of oil, fuel and chemicals will be surrounded by bunds or other containment device to prevent spilled oil, fuel and chemicals from percolating into the ground or reaching the receiving waters;
- The EPC Contractor will prepare unloading and loading protocols for the and train staff to prevent spills and leaks
- The EPC Contractor will prepare guidelines and procedures for immediate clean-up actions following any spillages of oils, fuels or chemicals;
- A site specific Emergency Response Plan will be prepared by the EPC Contractor for soil clean-up and decontamination; and
- The construction contractor will implement a training program to familiarise staff with emergency procedures and practices related to contamination events.

The measures in place to properly manage waste and thereby minimize any impacts to soil and sediment quality are:

- Design processes to prevent/minimise quantities of wastes generated and hazards associated with the waste generated;
- Training labourers for waste disposal in designated areas and use of sanitation facilities;

- Proper storage of the construction materials and wastes to minimise the potential damage or contamination of the materials; and
- Implementation of construction materials inventory management system to minimise over-supply of the construction materials, which may lead to disposal of the surplus materials at the end of the construction period.
- Segregation of hazardous and non-hazardous waste and provision of appropriate containers for the type of waste type (e.g. enclosed bins for putrescible materials to avoid attracting pests and vermin and to minimise odour nuisance);
- Storage of wastes in closed containers away from direct sunlight, wind and rain;
- Storage of waste systematically to allow inspection between containers to monitor leaks or spills;
- Ensuring that storage areas have impermeable floors and containment, of capacity to accommodate 110% of the volume of the largest waste container; and
- Disposal of waste by licensed contractors.

<b>Impact</b>	Impact on Soil Quality due to site development and construction of site access road			
Impact Nature	Negative	Positive		Neutral
Impact Type	Direct	Indirect		Induced
Impact Duration	Short Term	Medium Term		Long Term
Impact Extent	Local	Regional		National
Impact Scale	Low	Medium		High
Impact Magnitude	Negligible	Small	Medium	Large
Resource/ Receptor Sensitivity	Low	Medium		High
Impact Significance (Without Mitigations)	Negligible	Minor	Moderate	Major
	Significance of impact is considered <b>Minor</b>			
Impact Magnitude (With Mitigations)	Negligible	Small	Medium	Large
Impact Significance (With Mitigations) i.e. Residual Impact	Significance of impact is considered <b>negligible</b>			

### *Residual Impact*

Considering the implementation of above mentioned mitigations measures, the significance of residual impact is assessed as **negligible**.

## **4.5 Impact on Surface Water Quality due to Thermal Discharge**

### *Source of Impact*

- Discharge of cooling blow down water

### *Embedded Control Measures*

- Induced draft cooling system

### Impact Assessment

The cooling water blowdown at Bhola II is proposed to be routed to a guard pond, where it will be mixed with other water sources and fed to the effluent treatment plant, before ultimately being discharged to the Dehular Khal. The cooling water blowdown is designed to be at or marginally above (<1°C) the ambient temperature of the Khal.

Approximately 72 meters from the Bhola II discharge, the existing Bhola I plant has a discharge to the Khal of similar configuration. Though by design, Bhola II will discharge at or marginally above the ambient water temperature, modelling was conducted to consider the cumulative impacts of the Bhola I and Bhola II discharges for a theoretical temperature increase of 3.5°C above ambient from each discharge. The CORMIX module used is CORMIX3 for Buoyant Surface Discharges. ERM modelled the extent of the thermal plume for worst-case discharge conditions, which consists of the cooling water blowdown. Discharge flow is 0.19 m<sup>3</sup>/s and Initial temperature differential (°C) +3.5.

For the purpose of the modelling study a total of three (3) scenarios were used to model the thermal plume under varying ambient flow conditions.

1. Scenario-1 : Ambient flow rate- 5 m<sup>3</sup>/s
2. Scenario-2 : Ambient flow rate- 62 m<sup>3</sup>/s
3. Scenario-3 : Ambient flow rate- 124 m<sup>3</sup>/s

CORMIX Model Results: Table 4.4 summarizes the extent of the various resulting plumes (3°C temperature rise or reduction) in multiple dimensions, as characterized by three (3) indicators

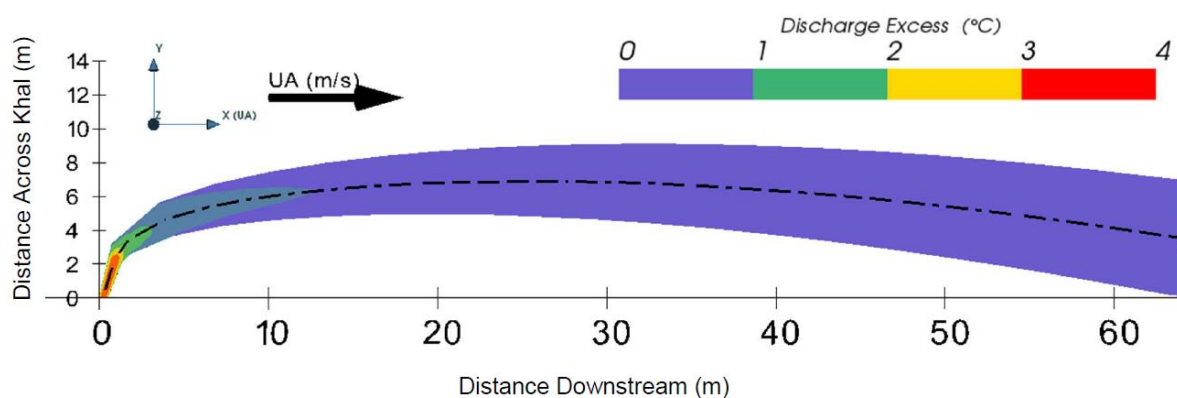
- Length of the plume (center -ine);
- Width of the plume; and
- Depth of plume.

**Table 4.4 Mixing Zone Dimensions Based on Plume Center-line for Each Scenario**

Scenario	Plume Length (m)	Width (m)	Thickness (m)
1	0.37	9.60	0.75
2	1.03	3.0	0.52
3	0.68	1.90	0.65

In all of the three (3) modelling scenarios, the IFC standards were met within ~1 m downstream. The centerline temperature is the maximum at each transect and temperatures decrease away from the centerline. The detailed plume behavior for the worst case downstream scenario (Scenario 2) is presented in following figure.

**Figure 4.3 Thermal Plume for the Worst Case Downstream Scenario (Scenario 2)**



All of the three (3) scenarios modelled meet the IFC standard of less than 3°C change within 100 m from either discharge. The farthest distance that either individual plume travels in any direction and in any scenario before meeting less than a 3°C change is 9.6 m across the Khal.

The overlap analysis demonstrates that the IFC standard of less than 3°C change within 100 m is met when considering the cumulative impacts of the Bhola I and Bhola II discharges. The excess temperature 100 m downstream from the Bhola II discharge is approximately 0.72°C.

The receptors within the small mixing zone of 9.6 m will have impact of change in temperature of 3°C or above. The receptors sensitivity within the small mixing zone has been considered as Medium. The significance of impact of cold water and machine cooling water will be **Minor**.

**Mitigation Measures:** It is suggested to further minimize impact of cooling blowdown discharge, following mitigation measures to be followed:

- Temperature checks to be performed regularly before discharge of cooling blowdown from plant.

Impact	Impact of cooling blowdown discharge on river water quality and biota.			
Impact Nature	Negative	Positive	Neutral	
Impact Type	Direct	Indirect	Induced	
Impact Duration	Short Term	Medium Term	Long Term	
Impact Extent	Local	Regional	National	
Impact Scale	Low	Medium	High	
Impact Magnitude	Negligible	Small	Medium	Large
Resource/ Receptor Sensitivity	Low	Medium	High	
Impact Significance (Without Mitigations)	Negligible	Minor	Moderate	Major
	Significance of impact is considered <b>Minor</b>			
Impact Magnitude (With Mitigations)	Negligible	Small	Medium	Large

Impact Significance (With Mitigations)

Significance of impact is considered **Minor**.

### *Residual Impact*

Considering the implementation of above mentioned mitigation measures, the significance of residual impact of cooling blowdown discharge on river water quality and biota is assessed as **Minor**.

The Thermal discharge modelling report has been provided in **Appendix C**.

## **4.6 Impact on Surface Water Quality and aquatic ecology due Accidental Oil Spill in the River**

### *Source of Impact*

- Accidental spillage of HSD during transportation.

### *Embedded Control Measures*

- Safety measures as per Bangladesh Petroleum Rules 1937 for transportation of petroleum product

### *Impact Assessment*

The proposed project will use HSD as backup fuel and HSD will be transported through oil tankers in waterways (Tetulia River and Dehular Khal). During transportation of oil, accidental spillage may occur due to leakage or rupture of oil tanker. NBBL has conducted oil spill modelling to assess the potential impact of river water quality and aquatic ecology of the area.

When oil is spilled on water it normally spreads out and moves on the water surface with wind and current while undergoing a number of chemical and physical changes. These processes are collectively termed weathering and determine the fate of the oil. Some of these processes, like natural dispersion of the oil into the water, lead to the removal of the oil from the sea surface, and facilitate its natural breakdown in the marine environment. Others, particularly the formation of water-in-oil emulsions, cause the oil to become more persistent, and remain at sea or on the shoreline for prolonged periods of time.

The weathering of the hypothetical spill volumes of HSD resulting from the proposed project during berthing and/or vessel collision has been modelled using *ADIOS (Automated Data Inquiry for Oil Spills)* online tool.

Confluence of Tetulia River and Dehular Khal - 22°29'1.14"N & 90°39'18.09"E area has been considered for modelling study. The two spill volumes have been considered:

- 150 MT, representing the upper end of an accidental spill such as a process leak;
- 300 MT, considered the largest instantaneous volume that would be spilled in the event of a side-on collision resulting in the rupture of a full tank.

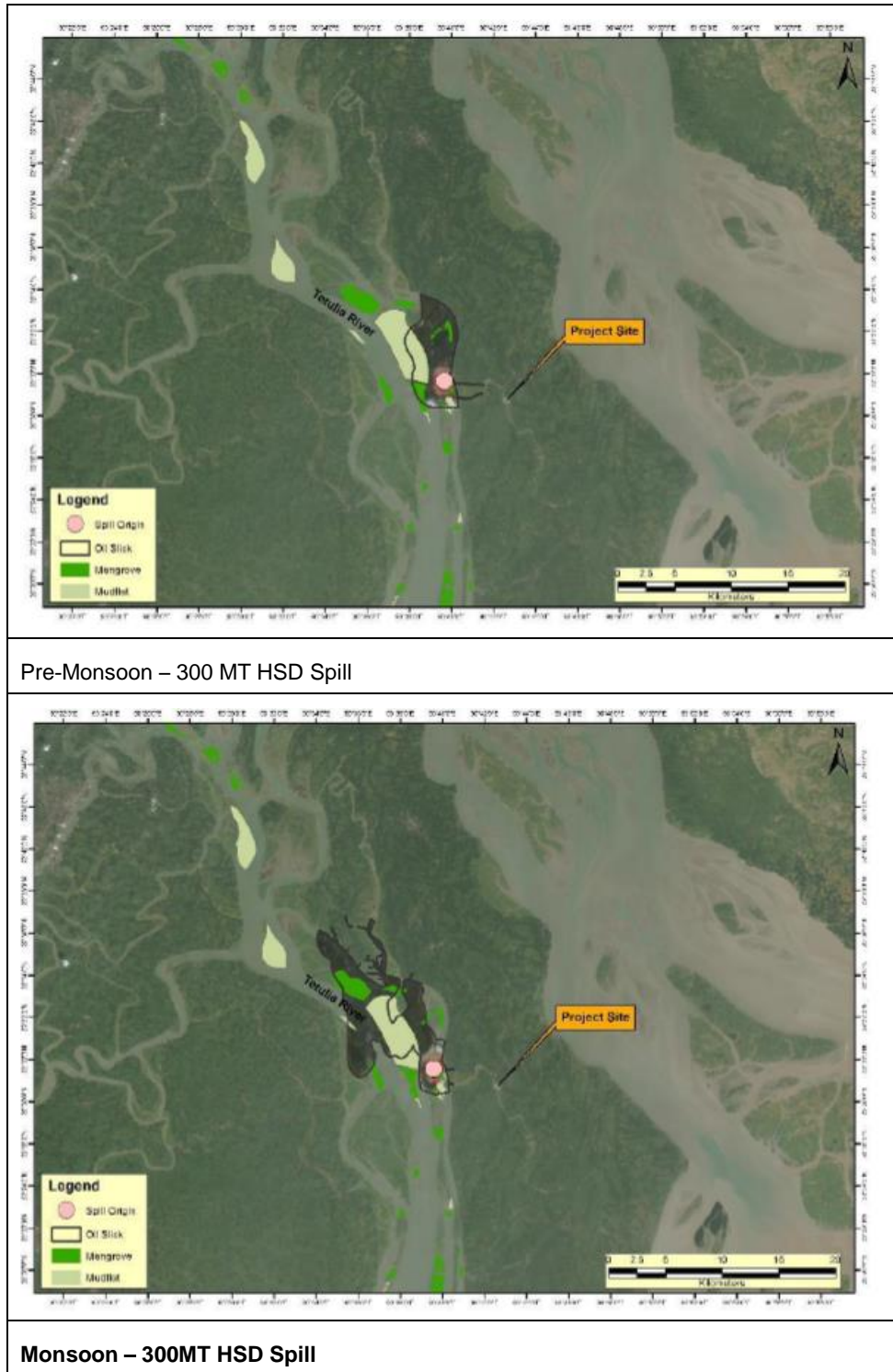
Oil Spill Release Scenarios and potential impacted area has been presented in Table 4.5. The Oil Spill Trajectory of worst case scenario has been presented in **Figure 4.4**.

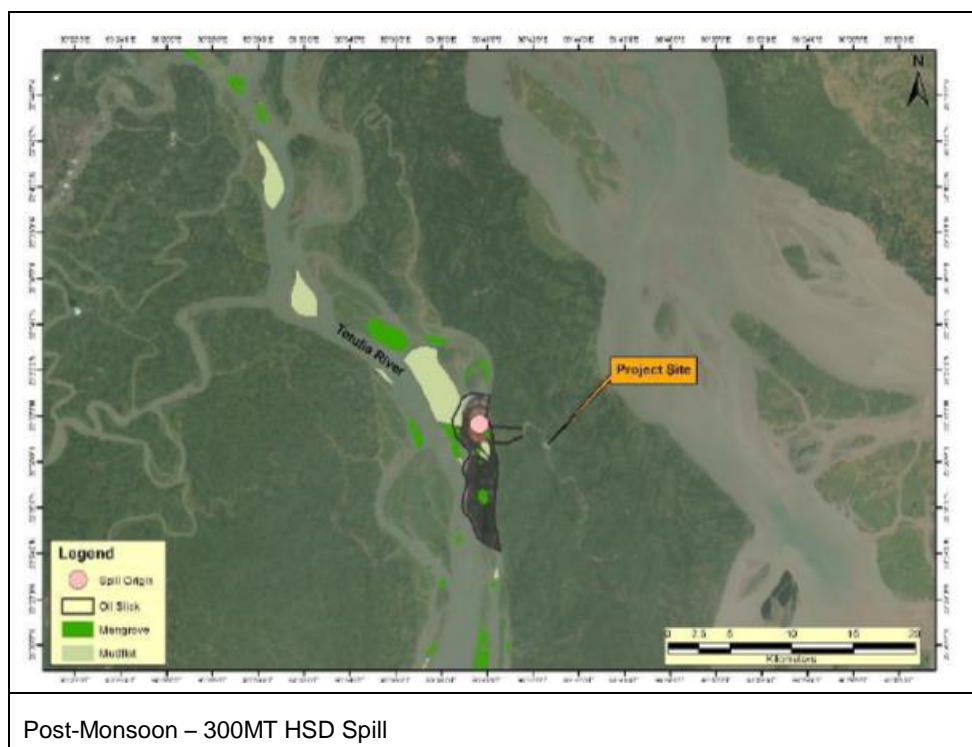


**Table 4.5 Oil Spill Release Scenarios and Potential Impact Zone**

Scenario	Oil Type	Season	Release Duration	Release Hour	Volume Released (MT)	Area of Impact
1	HSD	Pre- monsoon	Instantaneous	24 hrs	150	Oil spill of 150 MT during pre-monsoon on Tentulia River is likely to spread to a maximum distance of ~11km towards the north affecting small patches of mangroves, mud flats, shoreline and agricultural lands of nearby villages.
2	HSD	Pre- monsoon	Instantaneous	24 hrs	300	Oil spill of 300 MT during pre-monsoon on Tentulia River. The spill assessed to be spreading to a maximum distance of ~11km towards the north affecting small patches of mangroves, mud flats, shoreline and agricultural land of nearby villages.
3	HSD	Monsoon	Instantaneous	24 hrs	150	Oil spill of 150 MT during monsoon on Tentulia River is likely to spread to a maximum distance of ~14km towards the north-west affecting patches of mangroves, mud flats and shoreline of nearby villages on either side of the river.
4	HSD	Monsoon	Instantaneous	24 hrs	300	Oil spill of 300 MT during monsoon on Tentulia River is likely to spread to a maximum distance of ~17km towards the north-west affecting patches of mangroves, mud flats and shoreline of nearby villages on either side of the river.
5	HSD	Post monsoon	Instantaneous	24 hrs	150	Oil spill of 150 MT during post-monsoon on Tentulia River is likely to spread to a maximum distance of ~11km towards the south affecting patches of mangroves, mud flats and shoreline of nearby villages viz. Nazirpur and Bara Pata.
6	HSD	Post monsoon	Instantaneous	24 hrs	300	Oil spill of 300 MT during post-monsoon on Tentulia River is likely to spread to a maximum distance of ~12km towards the south affecting patches of mangroves, mud flats and shoreline of nearby village's viz. Nazirpur and Bara Pata.

Figure 4.4 Oil Spill Trajectory Scenarios





The potential impact on surface water quality and aquatic ecology including fishery and mangrove vegetation due to accidental oil spill in the river– is assessed to be **high** scale of impact. The duration of impact is **short term**, only during accidental discharge and such impact is likely to be exhibited during the first 24 hours of instantaneous release. The extent of impact is assessed to be beyond the 10 km from the place of release; however considering the potential spill location is located at a radial distance of 5km from the project location, NBBL shall not be able to control the spill in isolation but through a mutual aid scheme with nearby industries and support from regulatory authorities viz. Bangladesh Coast Guard, Bangladesh Inland Waterways Authority (BIWTA). The resource/ receptor sensitivity is assessed to be **high**, as project site fish habitat, mangrove vegetation and other aquatic fauna. The impact on soil/ sediment quality is assessed to be **major**.

### Mitigation measures

- Implementation of oil spill response measures as suggested Oil Spill Response and Control Plan.

<b>Impact</b>	Impact on river quality and aquatic ecology and mangrove due to accidental oil spill			
Impact Nature	Negative	Positive	Neutral	
Impact Type	Direct	Indirect	Induced	
Impact Duration	Short Term	Medium Term	Long Term	
Impact Extent	Local	Regional	National	
Impact Scale	Low	Medium	High	
Impact Magnitude	Negligible	Small	Medium	Large
Resource/ Receptor Sensitivity	Low	Medium		High
Impact Significance (Without Mitigations)	Negligible	Minor	Moderate	Major
	Significance of impact is considered <b>Major</b>			
Impact Magnitude (With Mitigations)	Negligible	Small	Medium	Large

Impact Significance (With Mitigations) i.e. Residual Impact	Significance of impact is considered <b>moderate</b>
---	--

***Residual Impact:*** Considering the implementation of above mentioned mitigation measures, the significance of residual impact of accidental oil spill and impact on river water quality and biota is assessed as **moderate**.

The oil spill risk assessment and response plan has been provided in **Appendix D**.

## 4.7 Impact on Community Health & Safety Due charge of HSD Storage area and Temporary Natural Gas (NG) supply Arrangement

### *Source of Impact*

- Shifting of HSD storage are in additional land
- Temporary gas pipeline for supply of gas from Bhola I plant

### *Embedded Control Measures*

Further in consistent Bangladesh Petroleum Rules 1937, necessary safety consideration has been made in storage tank design so that adequate safe distance (>6.0 m) is maintained with the existing power transmission line.

### *Impact Assessment*

The risk assessment study has been carried out for HSD storage facility (modified location) and temporary gas pipeline.

#### HSD Storage tank

The risk assessment study of HSD storage facility reveals that in worst hazard for 300mm leak and ignition of diesel from storage tank failure will be experienced to a maximum radial distance of 66m from the source with potential lethal effects within 1 minute (Refer Section 5.6.2). This may not cause major risk to the nearby community. .

#### Temporary Pipeline

The risk assessment study of temporary gas pipeline reveals that in worst hazard (rupture of pipeline) for release and ignition of natural gas from the pipeline rupture will be experienced to a maximum radial distance of 32m from the source with potential lethal effects within 1 minute. This may not cause major risk to the nearby community.

### *Mitigation Measures*

- Obtain necessary approval from Department of Explosives, Bangladesh for revision in the earlier approved diesel storage layout.
- Regulator must be Low Differential type. There must have an off-take in the Inlet of fuel gas conditioning skid for internal pipeline from Permanent RMS.
- All pipe, equipment, valves and fittings of RMS from inlet to delivery point must be 300 class rating or equivalent as applicable.
- Construction/fabrication of temporary RMS and pipeline works shall be carried out by a 1.4 category contractor enlisted with Petrobangla or its subsidiary companies having minimum experience in construction/fabrication of similar RMS and Pipeline.
- Obtain permission from the Chief Inspector, Explosive Department, EMRD, Bangladesh for the temporary RMS and 315 m gas pipeline length.

- Natural Gas Safety Rules-1991 (Revised-2003) and related applicable codes, standards governing in Bangladesh shall be followed

<b>Impact</b>	Impact on community health & safety due charge of HSD Storage area and Temporary NG supply Arrangement			
<b>Impact Nature</b>	Negative	Positive	Neutral	
<b>Impact Type</b>	Direct	Indirect	Induced	
<b>Impact Duration</b>	Short Term	Medium Term	Long Term	
<b>Impact Extent</b>	Local	Regional	National	
<b>Impact Scale</b>	Low	Medium	High	
<b>Impact Magnitude</b>	Negligible	Small	Medium	Large
<b>Resource/ Receptor Sensitivity</b>	Low	Medium	High	
<b>Impact Significance (Without Mitigations)</b>	Negligible	Minor	Moderate	Major
	Significance of impact is considered <b>Minor</b>			
<b>Impact Magnitude (With Mitigations)</b>	Negligible	Small	Medium	Large
<b>Impact Significance (With Mitigations) i.e. Residual Impact</b>	Significance of impact is considered <b>Negligible</b>			

### *Residual Impact*

Considering the implementation of above mentioned mitigation measures, the significance of residual impact on community health & safety due charge of HSD storage area and Temporary NG supply Arrangement is assessed as **negligible**.

## **4.8 Impact on Livelihood due to Land Procurement**

### *Sources of impact*

- Land required for main power plant including
- Land required for gas pipeline –

### *Embedded Control Measures*

The project embedded control measures are as follows:

- Land owners including warisans of the land has been compensated as per Govt. Rule

### *Impact Assessment*

#### Land Procurement for Power Plant

The land required for main power plant is 30.65 acres. 13.22 acres of land was taken on lease from BPDB and BIWTA and 17.43 acres of land has been procured from 130 land owners based on negotiated settlement process. The procured agricultural and was 2 season cropped land (Low lying land)/ 3 cropped land (high land). The procurement of land has impact on loss of livelihood of 130 project affected families.

For procurement of lad the land compensation rate was adopted for all land procured for NBBL from 2016 to 2019. The compensation amount land procured land was determined three ties of BDT 12,313 per decimal of land. The procurement land has reduced the land holding & quantity of produce, the livelihood compensation amount paid to PAPs have been satisfying.

#### Land Procurement for Gas Pipeline

The approximate of length of the proposed pipeline from supply gas to power plant is 6.7 km. To lay the pipeline, 6m width (3m on both side of the centre of the pipeline) Right of Use (ROU) land will be required. Apart from the RoU land, additional 12 m width (6m on both side of ROU) Requisition Land will be required for laying of pipeline. It was reported that 4.64 acres of land will be acquired for ROU. The land compensation rate for ROU of gas pipeline is under the jurisdiction of District Commissioner's Office with the applicability of The Acquisition and Requisition of Immovable Property Act, 2017. For Requisition Land, crop compensation amount will be given to the land owners/users.

### Land Users

As per Livelihood Restoration and Development Plan (LRDP) -prepared by AECOM, only 38 sharecroppers/labours has been identified. As per LRDP, majority of land users were not traceable, the information was that they have moved out of village to other unknown locations and not in contact with the owners or other villagers. The consultation with remaining land users reveals that land users have changed their occupation, like cultivator to wage labourer, contract worker etc. The consultation also reported that they have not received any compensation for loss of livelihood.

The duration of impact is assessed to be long-term, as the land is procured permanently. The land compensation has been provided for land owners and compensation has been provided to only the land owners and land users has not been considered. As it one time compensation without any assurance of job and economic opportunity; the scale of impact is assessed to be medium. The extent of impact is only limited to project footprint. The receptor sensitive is medium, as the most of the PAP livelihood is unskilled labour and they do not have any skill set for other technical job. The impact on livelihood due to land acquisition/ procurement for the project is assessed to be **Moderate**.

### Mitigation measures

- Engage the PAP in the project as per their skill
- R&R plan should consider the livelihood opportunity; like
  - Skill improvement training,
  - Planning and training for business
  - Initiative towards SHG
- Preference of local contractor to work under EPC contractor
- Include the land users in LRDP

Impact	Impact on livelihood due to procurement of land for the project			
Impact Nature	Negative	Positive		Neutral
Impact Type	Direct	Indirect		Induced
Impact Duration	Short Term	Medium Term		Long Term
Impact Extent	Local	Regional		National
Impact Scale	Low	Medium		High
Impact Magnitude	Negligible	Small	Medium	Large
Resource/ Receptor Sensitivity	Low	Medium		High
Impact Significance (Without Mitigations)	Negligible		Minor	Moderate
	Significance of impact is considered <b>Moderate</b>			
Impact Magnitude (With Mitigations)	Negligible	Small	Medium	Large

Impact Significance (With Mitigations) i.e. Residual Impact

Significance of impact is considered **Minor**

### *Residual Impact*

Considering the implementation of above mentioned mitigation measures, the residual impact on livelihood is assessed to be **minor**.

The LRDP has been provided in **Appendix E**.

## 5. RISK ASSESSMENT

This section on Risk Assessment (RA) aims to provide a systematic analysis of the major risks that may arise as a result of the revision in the HSD storage layout and operation of the temporary natural gas pipeline and RMS with respect to the proposed dual fuel based (natural gas and HSD) combined cycle power plant (CCPP) in Bhola, Bangladesh. The RA process outlines rational evaluations of the identified risks based on their significance and provides the outline for appropriate preventive and risk mitigation measures. The output of the RA will contribute towards strengthening of the Emergency Response Plan (ERP) in order to prevent damage to personnel, infrastructure and receptors in the immediate vicinity of the plant. Additionally, the results of the RA can also provide valuable inputs for keeping risk at As Low As Reasonably Practicable (ALARP) and arriving at decisions for mitigation of high risk events.

The following section describes the objectives, methodology of the risk assessment study and assessment for each of the potential risk separately. This includes identification of major hazards, hazard screening and ranking, frequency and consequence analysis for major hazards. The hazards have been quantitatively evaluated through a criteria base risk evaluation matrix. Risk mitigation measures to reduce significant risks to acceptable levels have also been recommended as a part of the risk assessment study.

### 5.1 RA Study Objective

The overall objective of this RA with respect to the proposed project involves identification and evaluation of major risks, prioritizing risks identified based on their hazard consequences and using the outcome to guide and strengthen both onsite and offsite ERP. Hence in order to ensure effective management of any emergency situations that may arise from failure of High Speed Diesel (HSD) storages and natural gas supply pipelines, the following specific objectives need to be achieved.

- Identify potential risk scenarios that may arise from revised storage area of diesel (including its unloading operations) and supply of natural gas via temporary pipelines;
- Review existing information and historical databases to arrive at possible likelihood of such risk scenarios;
- Predict the consequences of such potential risk scenarios and if consequences are observed to be high, establish the same through application of quantitative simulations; and
- Recommend feasible preventive and risk mitigation measures as well as provide inputs for strengthening of the project Emergency Response Plan (ERP).

### 5.2 RA Methodology

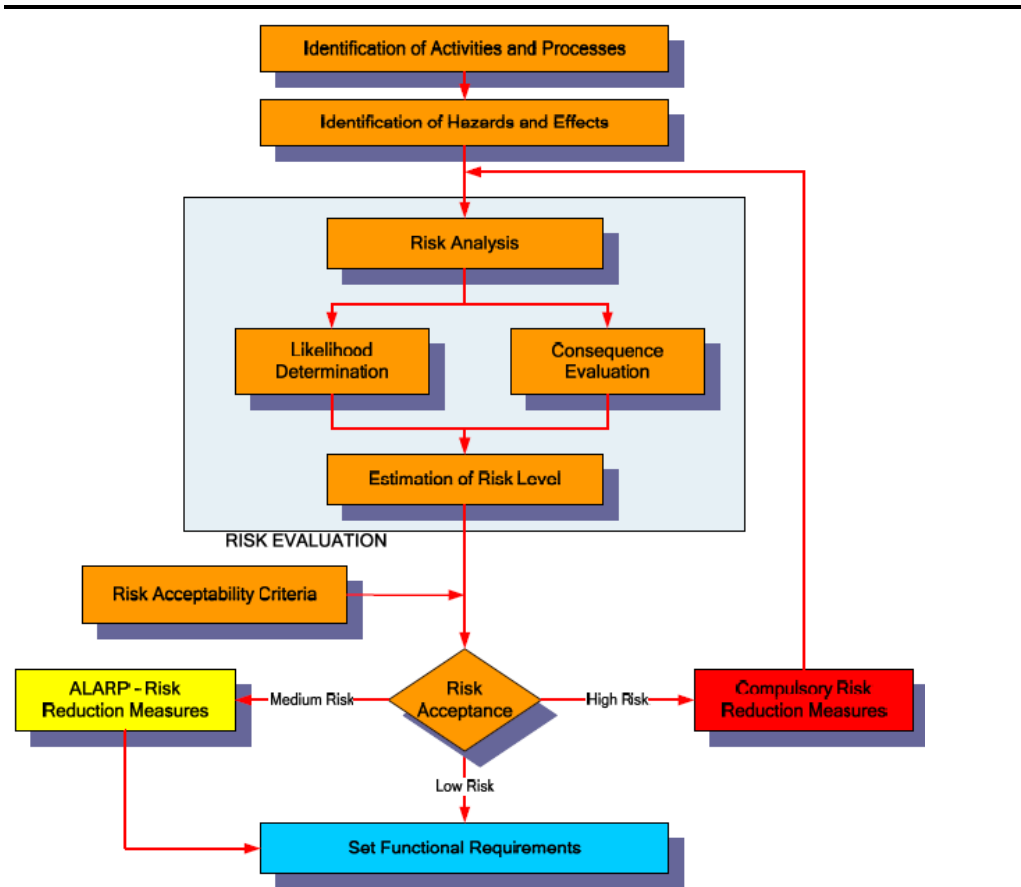
The risk assessment process is primarily based on likelihood of occurrence of the risks identified and their possible hazard consequences particularly being evaluated through hypothetical accident scenarios. With respect to the proposed project, major risks viz. leaks and rupture of storage tanks and pipelines been assessed and evaluated through a risk matrix generated to combine the risk severity and likelihood factor. Risk associated with the proposed dual fuel based CCPP project have been determined semi-quantitatively as the product of likelihood/probability and severity/consequence by using order of magnitude data (*risk ranking = severity/consequence factor X likelihood/probability factor*). Significance of such project related risks was then established through their classification as high, medium, low, very low depending upon risk ranking.

The risk matrix is widely accepted as standardized method of risk assessment and is preferred over purely quantitative methods, given that it's inherent limitations to define a risk event is certain. Application of this tool has resulted in the prioritization of the potential risks events for the existing



operations and proposed expansion thus providing the basis for drawing up risk mitigation measures and leading to formulation of plans for risk and emergency management. The overall approach is summarized below in **Figure 5.1**.

**Figure 5.1 Risk Assessment Methodology**



### 5.3 Safety Measures for Proposed Flammable Storages & Pipeline

Adequate number of gas leak detection and fire detection system as per stipulated norms will be provided for the pipeline supply of natural gas. Gas flow measurement system with integrator and local/remote indication will also be installed.

The fuel oil storage is planned to be provided with firefighting facilities in accordance to the provision of the Petroleum Act, 2016 and subsequent rules which requires provision of adequate supply of dry or other efficient means of extinguishing petroleum fires, at every installation. Furthermore, motor and control switch gear will be of flame proof construction satisfying the requirements of the British Standard Specification No. 4683:Part 2. Also as required under this Act, fuel oil storage tanks are constructed of iron or steel properly erected and designed according to sound engineering practice and will be properly equipped with dual earthing. Prior to the usage of the tanks, all bulk fuel storage tanks shall be tested by water pressure by NBBL to check for any leakages. Based on proposed designs, all storage tanks on site will be provided with secondary containment equipped with valves and will be able to contain leaks and spills

## 5.4 Hazard Identification

The first stage in any risk assessment is to identify the potential incidents that could lead to the release of a hazardous material from its normal containment and result in a major accident. This is achieved by a systematic review of the facilities to determine where a release of a hazardous material could occur from various parts of the installation.

The major hazards are generally one of three types: flammable, reactive and/or toxic. In this study, only flammable hazards are relevant involving loss of containment of diesel and leakage from natural gas pipeline. Flammable hazards may manifest as high thermal radiation from fires and overpressures following explosions that may cause direct damage, building collapse, etc. Flammable hazards are present throughout the facility and associated pipelines. Fires may occur if flammable materials are released to the atmosphere and ignition takes place.

Based on the result of this exercise, potential hazards that may arise due to proposed project were identified and a qualitative understanding of their probability and significance were obtained. Taking into account the applicability of different risk aspects the following hazards have been identified with respect to the proposed project which has been dealt in detail in the subsequent sections.

- Release of diesel from failure of loading/unloading line or hose and from storage tank leaks may lead to jet fire (from immediate ignition), pool fire and VCE (from delayed ignition); and
- Accidental release of natural gas from pipelines leading to jet fire, flash fire or vapour cloud explosion (VCE).

### 5.4.1 Hazards from Flammable Liquid Storages and Gas Pipelines

This study is only concerned with 'major hazards', which are as follows:

- Jet fires associated with pipework failures;
- Hydrocarbon fires associated with tank failures;
- Storage tank fires;
- Vapour cloud explosions; and
- Flash fires.

Each of these hazards has been described below.

#### 5.4.1.1 Jet Fire

Jet fires result from ignited releases of pressurized flammable gas or superheated/pressurized liquid. The momentum of the release carries the material forward in a long plume entraining air to give a flammable mixture. Jet fires only occur where the LNG is being handled under pressure or when handled in gas phase and the release is unobstructed.

#### 5.4.1.2 Pool Fires

The principal type of hydrocarbon fire of interest in this study is a pool fire. If a liquid release has time to form a pool and is then ignited before the pool evaporates or drains away, then a pool fire results. Because they are less well aerated, pool fires tend to have lower flame temperatures and produce lower levels of thermal radiation than some other types of fire (such as jet fires); however, this means that they will produce more smoke. Although a pool fire can still lead to structural failure of items within the flame, this will take several times longer than in a jet fire. An additional hazard of pool fires is their ability to move. A burning liquid pool can spread along a horizontal surface or run down a

vertical surface to give a running fire. Due to the presence of kerbs, slopes, drains and other obstacles; pool fire areas and directions can be unpredictable.

For this study, pool fires have been limited to the bund size used for a full bund fire; one-fourth of the bund size for small bund fire; and 100m pool diameter for unconfined fires.

### 5.4.1.3 Flash Fire

Vapour clouds can be formed from the release of flashing liquids of pressurized flammable material as well as from non-flashing liquid releases where vapour clouds can be formed from the evaporation of liquid pools or from an overflowing of storage tanks or vessels.

Where ignition of a release does not occur immediately, a vapour cloud is formed and moves away from the point of origin under the action of the wind.

This drifting cloud may undergo delayed ignition if an ignition source is reached, resulting in a flash fire if the cloud ignites in an unconfined area or vapour cloud explosion (VCE) if within confined area.

Flash fires are considered to be possible as a result of overflowing of storage tanks. Vapour from evaporating pools is not considered to result in flash fires due to slower evaporation rates. The cloud typically stays above the liquid pool and does not disperse significantly out of the bund limits. Should vapour be ignited it will most likely initiate a pool fire of the released pool.

### 5.4.1.4 Vapour Cloud Explosion

If the generation of heat in a fire involving a vapour-air mixture is accompanied by the generation of pressure then the resulting effect is a vapour cloud explosion (VCE). The amount of overpressure produced in a VCE is determined by the reactivity of the gas, the strength of the ignition source, the degree of confinement of the vapour cloud, the number of obstacles in and around the cloud and the location of the point of ignition with respect to the escape path of the expanding gases.

## 5.5 Frequency Analysis

The frequency analysis of the hazards identified with respect to the proposed project CID was undertaken to estimate the likelihood of their occurrences during the project life cycle. Hazard frequencies in relation to the proposed project were estimated based on the analysis of historical accident frequency data and professional judgment. Based on the range of probabilities arrived at for different potential hazards that may be encountered with respect to the storage of diesel, supply of natural gas and handling of chlorine, the following frequency categories and criteria have been defined (Refer

**Table 5.1).**

**Table 5.1 Frequency Categories and Criteria**

Likelihood Ranking	Criteria Ranking (cases/year)	Frequency Class
5	Likely to occur often in the life of the project, with a probability greater than $10^{-1}$	Frequent
4	Will occur several times in the life of project, with a probability of occurrence less than $10^{-1}$ , but greater than $10^{-2}$	Probable

Likelihood Ranking	Criteria Ranking (cases/year)	Frequency Class
3	Likely to occur sometime in the life of a project, with a probability of occurrence less than $10^{-2}$ , but greater than $10^{-3}$	Occasional/Rare
2	Unlikely but possible to occur in the life of a project, with a probability of occurrence less than $10^{-3}$ , but greater than $10^{-6}$	Remote
1	So unlikely it can be assumed that occurrence may not be experienced, with a probability of occurrence less than $10^{-6}$	Improbable

Source: Guidelines for Developing Quantitative Safety Risk Criteria – Centre for Chemical Process and Safety

### 5.5.1 Frequency Analysis – Diesel Storage

Although the project involves CID with respect to location of the diesel storage tanks (capacity and other specifications unchanged), the most credible scenario of a diesel tank will be pool fire. In order to determine the probability of a pool fire occurring, the failure rate needs to be modified by the probability of the material finding an ignition source. The probability of a pool fire occurring in the event of a release is therefore equal to the product of the failure rate and the probability of ignition. The frequency of the release scenarios is represented in **Table 5.2** below. The ignition probability is dependent on a number of factors including the type of site, the release rate and the type of material released.

**Table 5.2 Tank Failure Frequency**

S. No	Type of Release	Failure Rate (per vessel per year)	Frequency
1	Catastrophic tanks failure	$5.0 \times 10^{-6}$	Remote
2	Small bund fire	$9.0 \times 10^{-5}$	Remote
3	Large bund fire	$6.0 \times 10^{-5}$	Remote

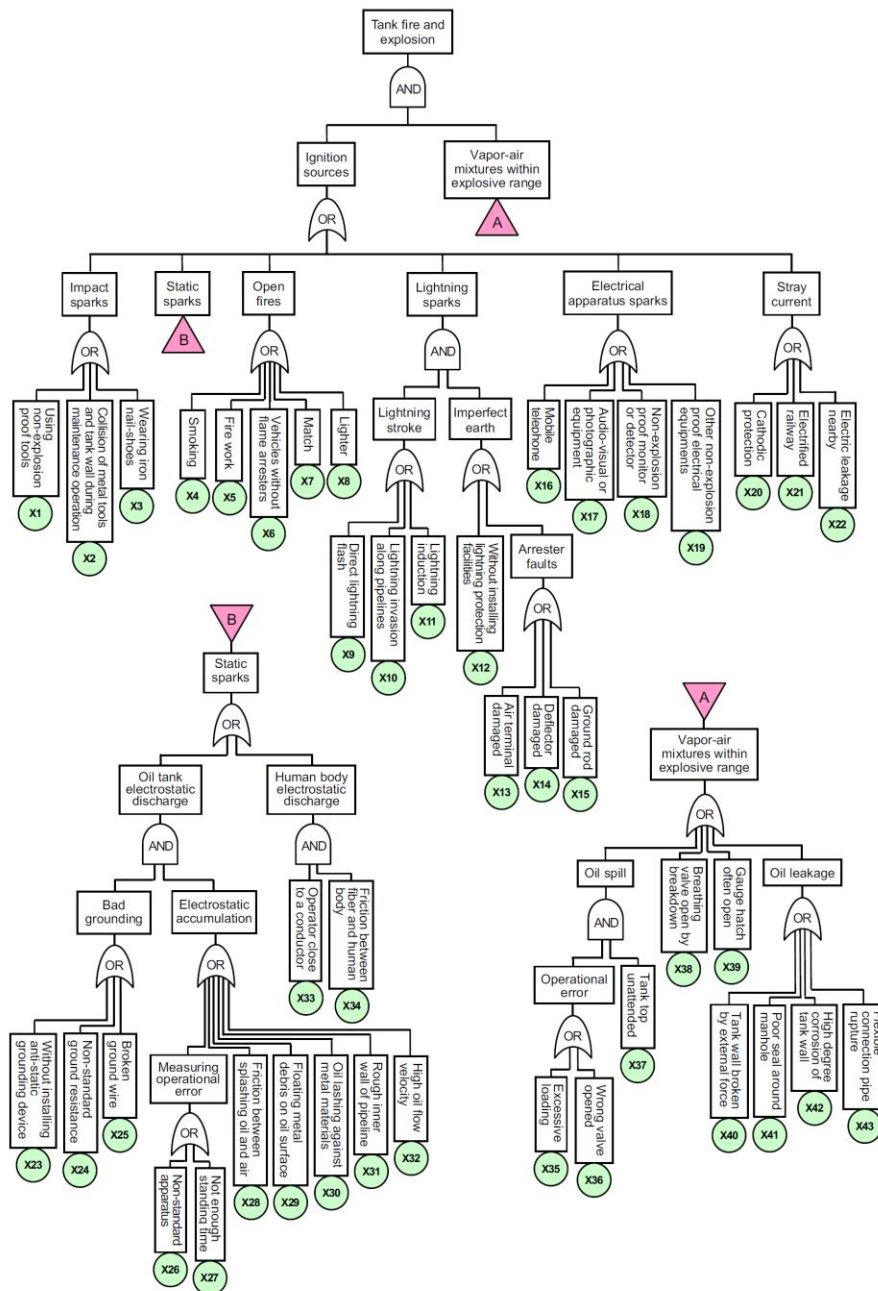
Source: OGP Risk Assessment Data Directory Report No 434 – 3, March 2010, Section 2 – Summary of Recommended Data

### Event Tree Analysis

Event tree analysis (ETA) is used to model the evolution of an event from the initial release through to the final outcome such as jet fire, fireball, flash fire etc. This may depend on factors such as whether immediate or delayed ignition occurs, or whether there is sufficient congestion to cause a vapour cloud explosion. The event tree for fire and explosion for an oil storage tank is shown in

**Figure 5.2.**

Figure 5.2 Event Tree Analysis - Tank Failure



Source: Fuzzy Fault Tree Analysis for Fire and Explosion in Crude Oil Tanks – Daqing Wang, Peng Zhang and Lijiong Chen, Journal of Loss Prevention in the Process Industries

### 5.5.2 Frequency Analysis – Pipeline

An effort has also been made to understand the primary failure frequencies of pressurised and temporary natural gas pipeline to be supplied to the site to serve as a fuel source till the main pipeline is operational. Based on the European Gas Pipeline Incident Data Group (EGIG) database the evolution of the primary failure frequencies over the entire period and for the last five years has been provided in

Table 5.3 below.

**Table 5.3 Primary Gas Pipeline Failure Frequency**

Period	No. of Incidents	Total System Exposure (km.yr)	Primary failure frequency (1000 km.yr)
1970-2007	1173	3.15.10 <sup>6</sup>	0.372
1970-2010	1249	3.55.10 <sup>6</sup>	0.351
1970-2013	1309	3.98.10 <sup>6</sup>	0.329
1970-2016	1366	4.41.10 <sup>6</sup>	0.310
2012-2016	97	0.72.10 <sup>6</sup>	0.136

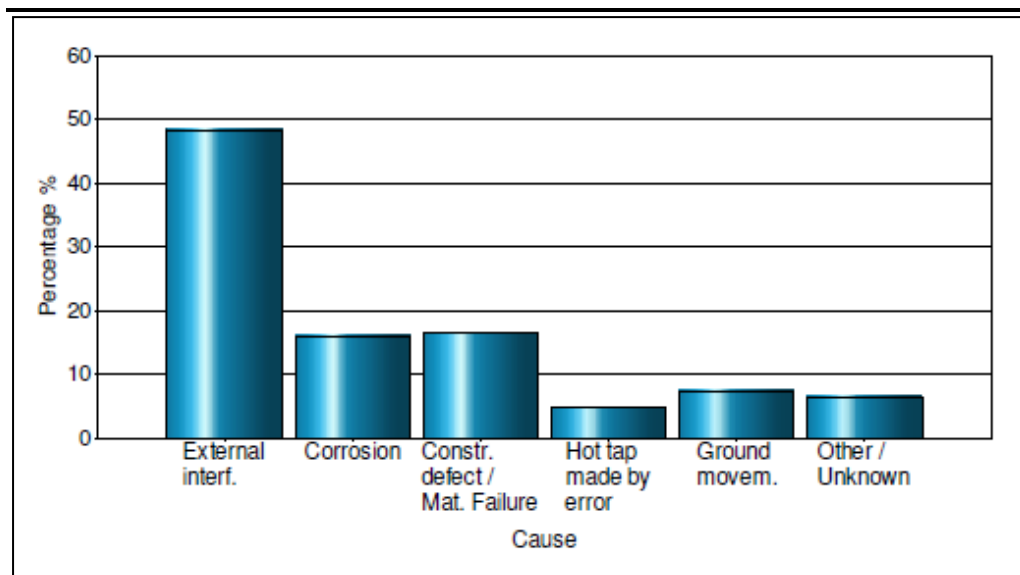
Source: 10th EGIG Report ([https://www.egig.eu/reports/\\$97/\\$157](https://www.egig.eu/reports/$97/$157))

As referred in the above table the overall failure frequency (0.331) of the entire period (1970-2016) is slightly lower than the failure frequency of 0.33 reported in the 9<sup>th</sup> EGIG report (1970-2013). The failure frequency of the last 5 years was found to be 0.14 per 1000km.year, depicting an improved performance over the recent years.

Incident Causes

Gas pipeline failure incidents can be attributed to the following major causes viz. external interference, construction defects, corrosion (internal & external), ground movement and hot tap. The distribution of incidents with cause has been presented in the **Figure 5.3** below.

**Figure 5.3 Gas Pipeline Failure – Distribution of Incident & Causes**



Source: 8<sup>th</sup> EGIG Report

The interpretation of the aforesaid figure indicated external interference as the major cause of pipeline failure contributing to about 48.4% of the total failure incidents followed by construction defects (16.7%) and corrosion related problems (16.1%). Ground movement resulting from seismic disturbance, landslides, flood etc. contributed to only 7.4% of pipeline failure incident causes.

Review of the 9<sup>th</sup> EGIG report indicates that primary failure frequency varies with pipeline diameter, and the same has been presented in **Table 5.4** below.

**Table 5.4 Primary Failure Frequency based on Diameter Class (1970-2013)**

Nominal Diameter (inch)	Primary failure frequency (per km.yr)		
	Pinhole/Crack	Hole	Rupture
diameter < 5"	4.45 X 10 <sup>-4</sup>	2.68 X 10 <sup>-4</sup>	1.33 X 10 <sup>-4</sup>
5" ≤ diameter < 11"	2.80 X 10 <sup>-4</sup>	1.97 X 10 <sup>-4</sup>	6.40 X 10 <sup>-5</sup>
11" ≤ diameter < 17"	1.27 X 10 <sup>-4</sup>	0.98 X 10 <sup>-4</sup>	4.10 X 10 <sup>-5</sup>
17" ≤ diameter < 23"	1.02 X 10 <sup>-4</sup>	5.00 X 10 <sup>-5</sup>	3.40 X 10 <sup>-5</sup>
23" ≤ diameter < 29"	8.50 X 10 <sup>-5</sup>	2.70 X 10 <sup>-5</sup>	1.20 X 10 <sup>-5</sup>
29" ≤ diameter < 35"	2.30 X 10 <sup>-5</sup>	5.00 X 10 <sup>-6</sup>	1.40 X 10 <sup>-5</sup>
35" ≤ diameter < 41"	2.30 X 10 <sup>-5</sup>	8.00 X 10 <sup>-6</sup>	3.00 X 10 <sup>-6</sup>
41" ≤ diameter < 47"	7.00 X 10 <sup>-6</sup>	-	-
diameter ≥ 47"	6.00 X 10 <sup>-6</sup>	6.00 X 10 <sup>-6</sup>	6.00 X 10 <sup>-6</sup>

Source: 9th EGIG Report

The pipeline failure frequency viz. leaks or rupture for the temporary natural gas pipeline has been computed based on the aforesaid table. For pipeline with diameter varying within 11 to 17 inches, the probability of pinhole is estimated to be **1.27 x 10<sup>-4</sup> per km year**, while full bore rupture is considered to be **4.10 x 10<sup>-5</sup> per km year**. **This is considered for estimating failure probability of the temporary natural gas pipeline having a 12 inch diameter which supplies to temporary metering skid onsite.** (Refer **Table 5.5** below).

**Table 5.5 Natural Gas Pipeline - Failure Frequency**

S. No	Pipeline Failure Case	EGIG Failure Frequency (per km.year)	Avg. Pipeline Length (km)	Project Pipeline Failure Frequency (per year)	Frequency
1	Natural Gas Pipeline Rupture	4.10 x 10 <sup>-5</sup>	0.3	1.23 x 10 <sup>-4</sup>	Remote
2	Natural Gas Pipeline Leak	1.27 x 10 <sup>-4</sup>	0.3	3.81 x 10 <sup>-5</sup>	Remote

Thus the probability of pipeline leak and rupture with respect to the pipeline transportation of natural gas as fuel to the site is identified to be as "Remote" (Refer **Table 5.1**).

### Pipeline Failure – Ignition Probability

The ignition probability of natural gas pipeline failure (rupture & leaks) with respect to the proposed project is derived based on the following equations as provided in the IGEM/TD/2 standard

$$P_{ign} = 0.0555 + 0.0137pd^2; \text{ for } 0 \leq pd^2 \leq 57$$

**(For pipeline ruptures)**



$$P_{ign} = 0.81; \text{ for } pd^2 > 57$$

$$P_{ign} = 0.0555 + 0.0137(0.5pd^2); \text{ for } 0 \leq 0.5pd^2 \leq 57$$

**(For pipeline leaks)**

$$P_{ign} = 0.81; \text{ for } 0.5pd^2 > 57$$



**Where:**

- $P_{ign}$  = Probability of ignition
- $p$  = Pipeline operating pressure (bar)
- $d$  = Pipeline diameter (m)

The ignition probability of natural gas release from a leak/rupture of 12inch temporary natural gas pipeline is calculated based on the above equations utilizing the following input parameters as discussed below.

### Natural Gas Pipeline

Normal Pipeline Inlet Pressure (bar) =  $p = 41.3$  bar

Pipeline diameter =  $d = 12$  inch or  $0.30$  m

For pipeline rupture  $pd^2 = (41.3) \times (0.30)^2 = 3.717$

For pipeline leak  $0.5pd^2 = 0.5 \times (41.3) \times (0.30)^2 = 1.858$

Since  $0 \leq pd^2 \leq 57$  and  $0 \leq 0.5pd^2 \leq 57$ , the following equation has been utilized for deriving the ignition probability for failure.

$$P_{ign \text{ for pipeline rupture}} = 0.0555 + 0.0137pd^2 = 0.0555 + 0.0137(3.717) = 0.10$$

$$P_{ign \text{ for pipeline leak}} = 0.0555 + 0.0137(0.5pd^2) = 0.0555 + 0.0137(1.858) = 0.08$$

The probability of ignition for an accidental release of natural gas from pipeline temporarily supplying the site is presented in **Table 5.6** below:

**Table 5.6 Temporary Natural Gas Pipeline –Jet Fire Probability**

S. No	Pipeline Failure Case	Project Pipeline Failure Frequency (per year)	Ignition Probability	Jet Fire Probability
1	Natural Gas Pipeline Leak	$3.81 \times 10^{-5}$	0.08	$3.04 \times 10^{-6}$
2	Natural Gas Pipeline Rupture	$1.23 \times 10^{-4}$	0.10	$1.23 \times 10^{-5}$

Hence from the above table it can be concluded that ignition probability of natural gas that may be released from the supply pipeline due to any accidental event is considered to be unlikely.

## 5.6 Consequence Analysis

In parallel with the frequency analysis, hazard prediction / consequence analysis exercises were undertaken to assess the likely impact of project related risks on onsite personnel, infrastructure and environment. In relation to the proposed project as well as the existing activities have been considered, the estimation of the consequences for each possible event has been based either on accident frequency, consequence modeling or professional judgment, as appropriate. Overall, the consequence analysis takes into account the following aspects:

- Nature of impact on environment and community;
- Occupational health and safety;
- Asset and property damage;
- Corporate image; and
- Timeline for restoration of property damage.

The following criteria for consequence rankings (Refer **Table 5.7**) have been drawn up in context of the possible consequences of the risk events that may occur during the proposed project operations:

**Table 5.7 Severity Categories and Criteria**

Consequence	Ranking	Criteria Definition
Catastrophic	5	<ul style="list-style-type: none"> <li>• Multiple fatalities/permanent total disability to more than 50 persons.</li> <li>• Net negative financial impact of &gt;10 crores</li> <li>• International media coverage</li> <li>• Loss of corporate image and reputation</li> </ul>
Major	4	<ul style="list-style-type: none"> <li>• Single fatality/permanent total disability to one or more persons</li> <li>• Net negative financial impact of 5 -10 crores</li> <li>• National stakeholder concern and media coverage.</li> </ul>
Moderate	3	<ul style="list-style-type: none"> <li>• Short term hospitalization &amp; rehabilitation leading to recovery</li> <li>• Net negative financial impact of 1-5 crores</li> <li>• State wide media coverage</li> </ul>
Minor	2	<ul style="list-style-type: none"> <li>• Medical treatment injuries</li> <li>• Net negative financial impact of 0.5 – 1 crore</li> <li>• Local stakeholder concern and public attention</li> </ul>
Insignificant	1	<ul style="list-style-type: none"> <li>• First Aid treatment</li> <li>• Net negative financial impact of &lt;0.5 crores.</li> <li>• No media coverage</li> </ul>

### *Risk Evaluation*

Based on ranking of likelihood and frequencies, each identified hazard has been evaluated based on the likelihood of occurrence and the magnitude of consequences. The significance of the risk is expressed as the product of likelihood and the consequence of the risk event, expressed as follows:

**Significance = Likelihood X Consequence**

The

**Table 5.8** below illustrates all possible product results for the five likelihood and consequence categories while the **Table 5.9** assigns risk significance criteria in three regions that identify the limit of risk acceptability. Depending on the position of the intersection of a column with a row in the risk

matrix, hazard prone activities have been classified as low, medium and high thereby qualifying for a set of risk reduction / mitigation strategies.

**Table 5.8 Risk Matrix**

		Likelihood →					
		Frequent	Probable	Unlikely	Remote	Improbable	
		5	4	3	2	1	
Consequence ↑	Catastrophic	5	25	20	15	10	5
	Major	4	20	16	12	8	4
	Moderate	3	15	12	9	6	3
	Minor	2	10	8	6	4	2
	Insignificant	1	5	4	3	2	1

**Table 5.9 Risk Criteria and Action Requirements**

S.N.	Risk Significance	Criteria Definition & Action Requirements
1	High (16 - 25)	<b>“Risk requires attention”</b> – Project HSE Management need to ensure that necessary mitigation are adopted to ensure that possible risk remains within acceptable limits
2	Medium (10 – 15)	<b>“Risk is tolerable”</b> – Project HSE Management needs to adopt necessary measures to prevent any change/modification of existing risk controls and ensure implementation of all practicable controls.
3	Low (5 – 9)	<b>“Risk is acceptable”</b> – Project related risks are managed by well-established controls and routine processes/procedures. Implementation of additional controls can be considered.
4	Very Low (1 – 4)	<b>“Risk is acceptable”</b> – All risks are managed by well-established controls and routine processes/procedures. Additional risk controls need not to be considered

### 5.6.1 Consequence Analysis – Tankages

The main hazards associated with the storage and handlings of fuels are pool fires resulting from the ignition of released material as well as explosions and Flash fires resulting from the ignition of a flammable cloud formed in the event of tank overfilling. The hazards may be realised following tank overfilling and leaks/failures in the storage tank and ancillary equipment such as transfer pumps, metering equipment, etc. all of which can release significant quantities of flammable material on failure.

#### Bulk Storage Tank Scenarios

In addition to overfill, the scenarios considered for the diesel storage tanks were partial/local failures and cold catastrophic failures. Factors that have been identified as having an effect on the integrity of

tanks are related to design, inspection, maintenance, and corrosion<sup>2</sup>. The following representative scenarios for the tanks were considered (Refer **Table 5.10**).

**Table 5.10 Diesel Storage Tank – Risk Modelling Scenarios**

S. No	Tank	Tank Diameter (m)	Tank Height (m)	Tank Volume (KL)	Accident Scenario	Threat Modelled
1	Diesel Tank	21.0	15.0	5192	50mm leak	Pool Fire
2		21.0	15.0	5192	100mm leak	Pool Fire
3		21.0	15.0	5192	300mm leak	Pool Fire VCE

The diesel storage tank failure risk scenarios have been modeled using ALOHA and interpreted in terms of Thermal Radiation Level of Concern (LOC) encompassing the following threshold values (measured in kilowatts per square meter) to create the default threat zones:

*Red: 10 kW/ (sq. m) -- potentially lethal within 60 sec;*

*Orange: 5 kW/ (sq. m) -- second-degree burns within 60 sec; and*

*Yellow: 2 kW/ (sq. m) -- pain within 60 sec*

For vapour cloud explosion, the following threshold level of concern has been interpreted in terms of blast overpressure as specified below:

*Red: 8.0 psi – destruction of buildings;*

*Orange: 3.5 psi – serious injury likely; and*

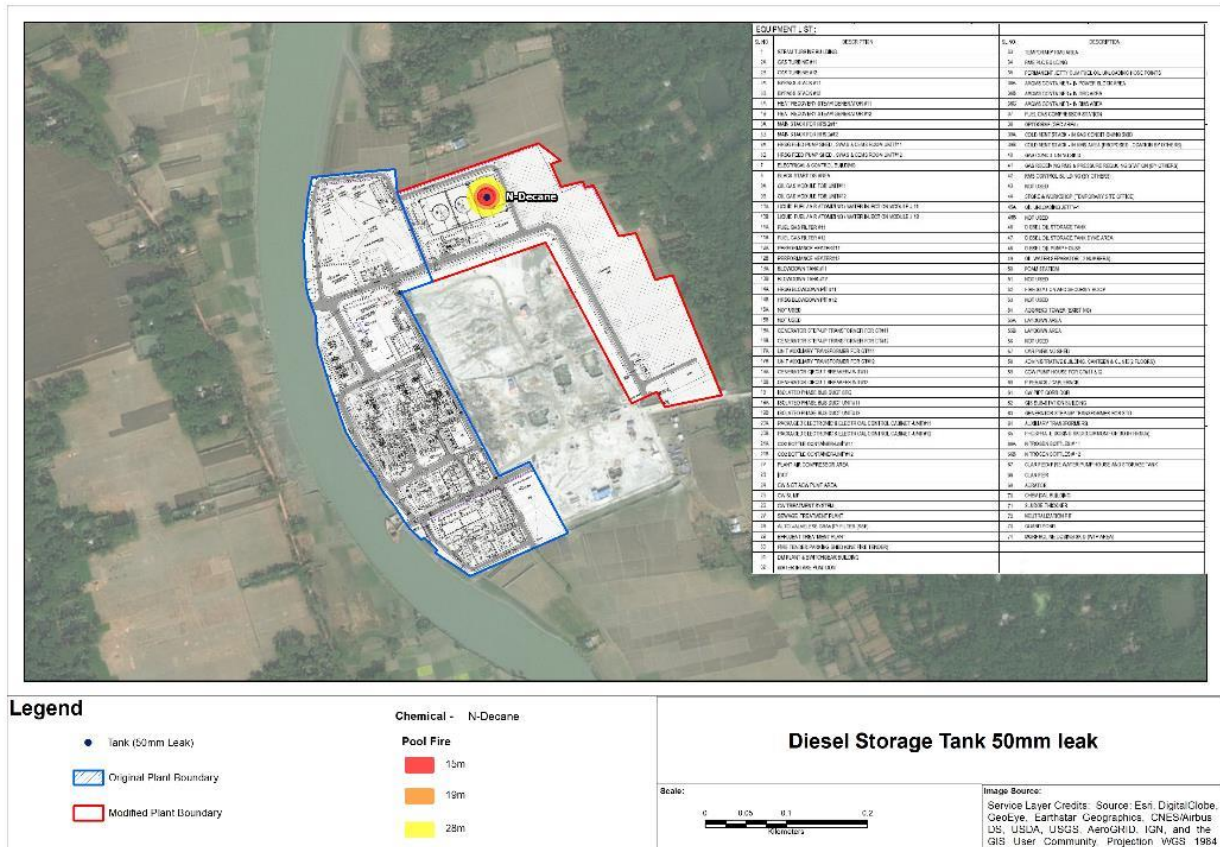
*Yellow: 1.0 psi – shatters glass*

<sup>2</sup> AEA Technology, HSE Guidance Document

Scenario 1: Diesel Storage Tank Failure – 50mm Leak

The pool fire threat zone plot for 50mm leak and ignition of diesel from storage tank failure is represented in **Figure 5.4** below.

**Figure 5.4 Threat Zone Plot –50mm leak**



Source: ALOHA

**THREAT ZONE:**

Threat Modeled: Thermal radiation from pool fire

Red : 15 meters --- (10.0 kW/ (sq. m) = potentially lethal within 60 sec)

Orange: 19 meters --- (5.0 kW/ (sq. m) = 2nd degree burns within 60 sec)

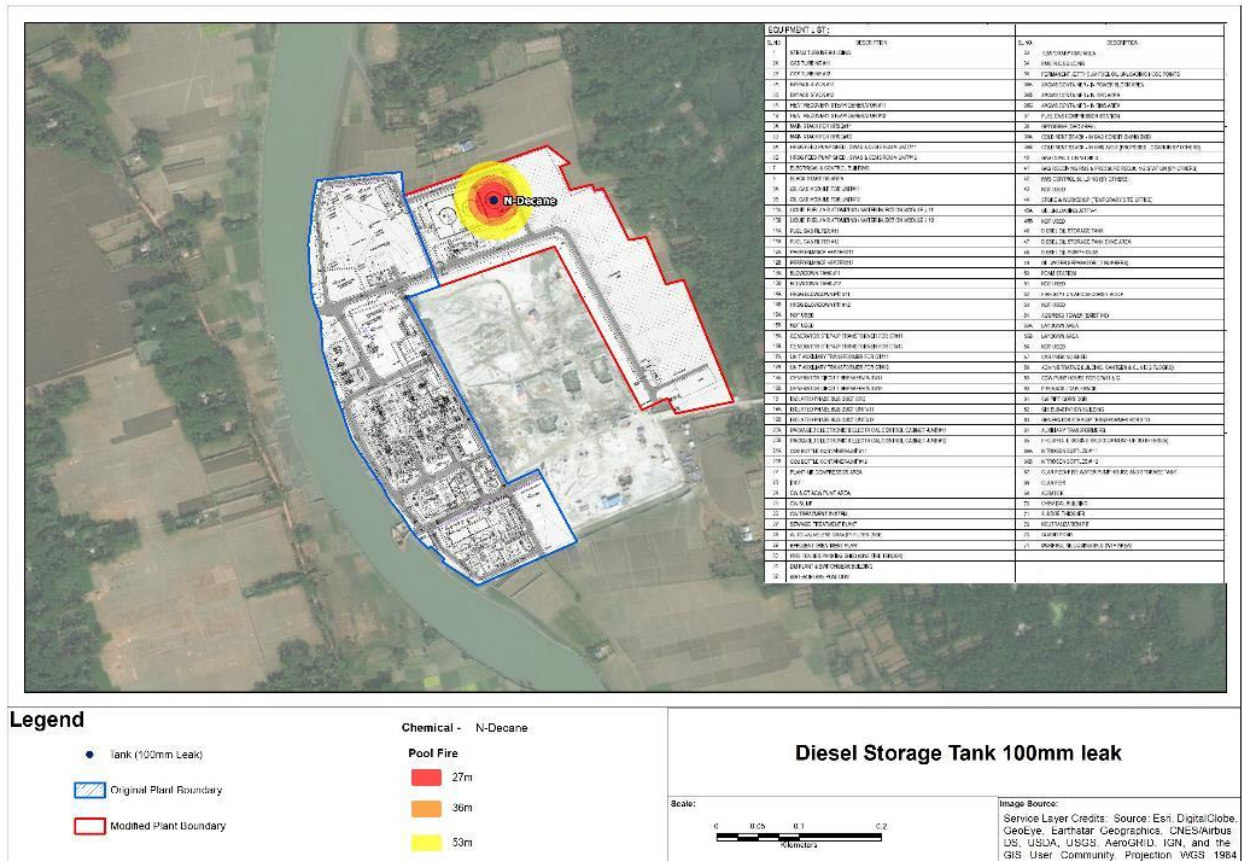
Yellow: 28 meters --- (2.0 kW/ (sq. m) = pain within 60 sec)

**The worst hazard for 50mm leak and ignition of diesel from storage tank failure will be experienced to a maximum radial distance of 15m from the source with potential lethal effects within 1 minute.**

Scenario 2: Diesel Storage Tank Failure – 100mm Leak

The pool fire threat zone plot for 100mm leak and ignition of diesel from storage tank failure is represented in in **Figure 5.5** below.

**Figure 5.5 Threat Zone Plot –100mm leak**



Source: ALOHA

**THREAT ZONE:**

Threat Modeled: Thermal radiation from pool fire

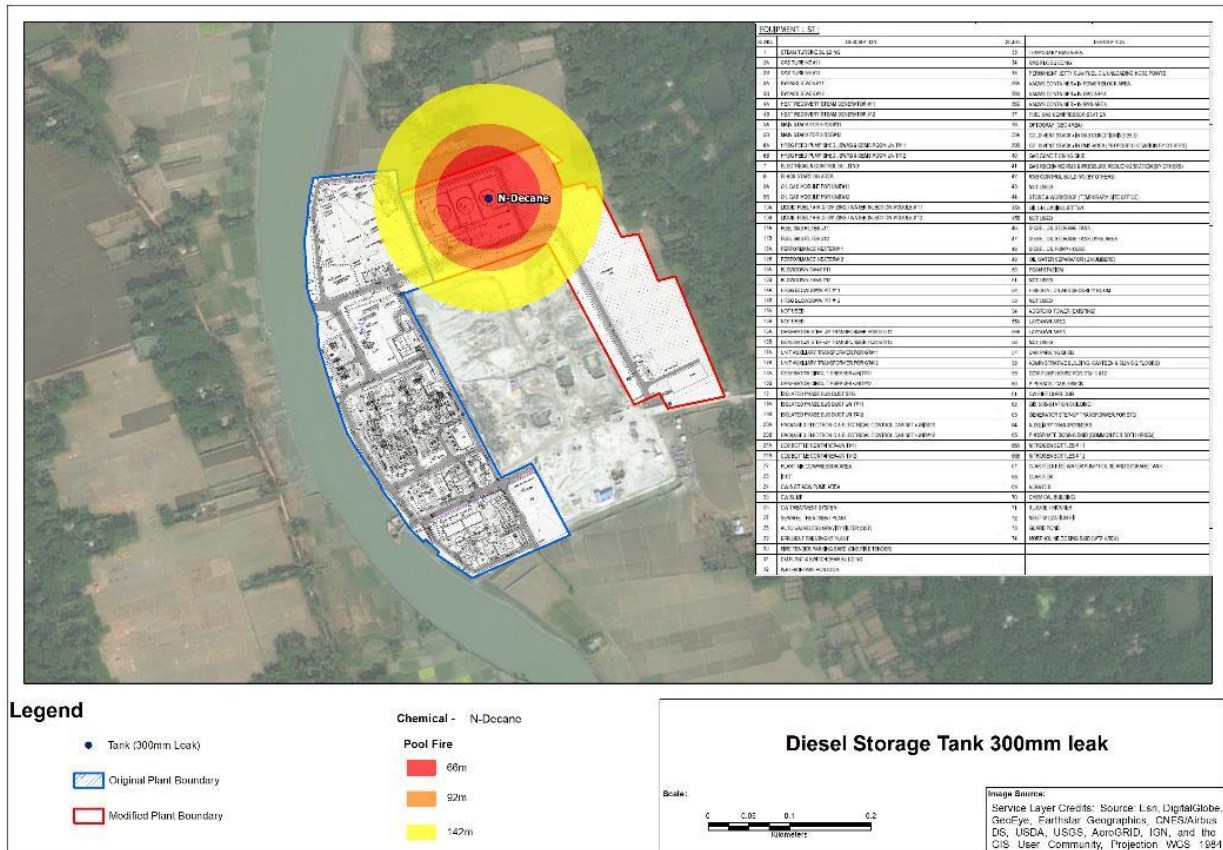
- Red : 27 meters --- (10.0 kW/ (sq. m) = potentially lethal within 60 sec)
- Orange: 36 meters --- (5.0 kW/ (sq. m) = 2nd degree burns within 60 sec)
- Yellow: 53 meters --- (2.0 kW/ (sq. m) = pain within 60 sec)

The worst hazard for 100mm leak and ignition of diesel from storage tank failure will be experienced to a maximum radial distance of 27m from the source with potential lethal effects within 1 minute.

Scenario 3: Diesel Storage Tank Failure – 300mm leak (Worst Case)

The pool fire threat zone plot for 300mm leak and ignition of diesel from storage tank failure is represented in **Figure 5.6** below.

**Figure 5.6 Threat Zone Plot –300 mm leak (Worst Case)**



Source: ALOHA

**THREAT ZONE:**

- Threat Modeled: Thermal radiation from pool fire
- Red : 66 meters --- (10.0 kW/ (sq. m) = potentially lethal within 60 sec)
- Orange: 92 meters --- (5.0 kW/ (sq. m) = 2nd degree burns within 60 sec)
- Yellow: 142 meters --- (2.0 kW/ (sq. m) = pain within 60 sec)

The worst hazard for 300mm leak and ignition of diesel from storage tank failure will be experienced to a maximum radial distance of 66m from the source with potential lethal effects within 1 minute. Superimposing the risk contours for the said worst case scenario on the site layout indicates the following project structures to be falling within the potential risk zones – NBBL: foam station, oil-water separator, store and workshop and Bhola-I: RMS and Switchyard. In addition to the above, the few village hutments located outside abutting the eastern boundary of the NBBL project is also found to be falling within the low risk zone (yellow).

For VCE modelled for catastrophic failure of diesel storage tank, the LOC level was never exceeded

**THREAT ZONE:**

Threat Modeled: Overpressure (blast force) from vapor cloud explosion

Type of Ignition: ignited by spark or flame

Level of Congestion: uncongested

Model Run: Heavy Gas

Red : LOC was never exceeded --- (8.0 psi = destruction of buildings)

Orange: LOC was never exceeded --- (3.5 psi = serious injury likely)

Yellow: LOC was never exceeded --- (1.0 psi = shatters glass)

For calculating the risk significance of diesel storage failure, the likelihood ranking is considered to be “2” as the failure probability for such failure is computed to be  $\sim 5 \times 10^{-6}$  per year. With respect to consequence ranking, for the aforesaid incident it has been identified to be as “3” given for a worst case scenario lethal effects for the revised diesel storage is likely to be experienced within a maximum radial zone  $\sim 66$  meters, with no social sensitivities located within fatal zone. Furthermore, considering that isolated diesel storages will be equipped appropriate state of the art process and fire safety controls in consistent with Petroleum Act, 2016 and subsequent rules requirements, the risk is likely to be less significant. Also in consistent said Rules necessary safety consideration has been made in storage tank design so that adequate safe distance ( $>6.0$  m) is maintained with the existing power transmission line.

*Risk Ranking – Diesel Tank Failure (Worst Case Scenario)*

Likelihood ranking	2	Consequence ranking	3
<b>Risk Ranking &amp; Significance =6 i.e. “Low” i.e. Risk is Acceptable and can be managed through use of existing controls with the option for installation of additional controls, if necessary.</b>			

**5.6.2 Consequence Analysis – Pipelines**

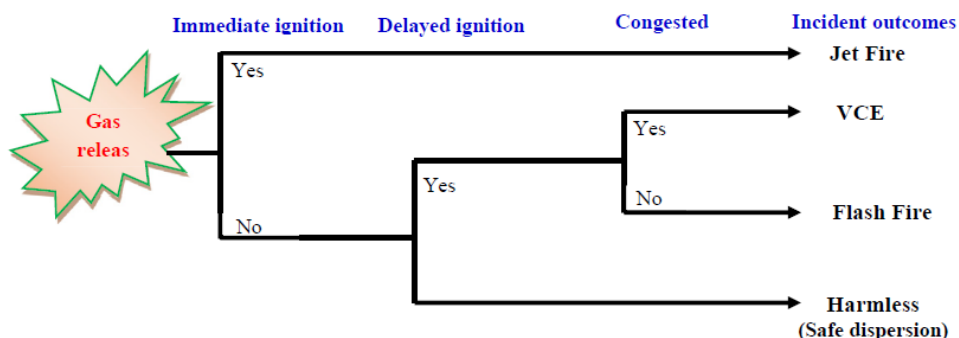
Pipeline generally contains large inventories of oil or gas under high pressure; although accidental releases from them are remote they have the potential of catastrophic or major consequences if related risks are not adequately analysed or controlled. The consequences of possible pipeline failure is generally predicted based on the hypothetical failure scenario considered and defining parameters such as meteorological conditions (stability class), leak hole & rupture size and orientation, pipeline pressure & temperature, physicochemical properties of chemicals released etc.

In case of pipe rupture containing highly flammable natural gas, an immediate ignition will cause a jet fire. Flash fires can result from the release of natural gas through the formation of a vapour cloud with delayed ignition and a fire burning through the cloud. A fire can then flash back to the source of the leak and result in a jet fire. Flash fires have the potential for offsite impact as the vapour clouds can travel considerable distances downwind of the source. Explosions can occur when a flammable gas cloud in a confined area is ignited; however where vapour cloud concentration of released material is lower than Lower Flammability Limit (LFL), consequently the occurrence of a VCE is highly unlikely. VCE, if occurs may result in overpressure effects that become more significant as the degree of confinement increases (Refer



Figure 5.7). Therefore, in the present study, only the risks of jet fires for the below scenarios have been modelled and calculated.

**Figure 5.7 Natural Gas Release – Potential Consequences**



[Source: “Safety risk modelling and major accidents analysis of hydrogen and natural gas releases: A comprehensive risk analysis framework” - Iraj Mohammadfam, Esmaeil Zare]

Based on the above discussion and frequency analysis as discussed in the earlier section, the following hypothetical risk scenarios (Refer **Table 5.11**) have been considered for consequence analysis of the temporary natural gas supply pipeline (12inch dia) of **300m length**.

**Table 5.11 Temporary Gas Pipeline Risk Modelling Scenarios**

Scenario	Pipeline	Accident Scenario	Design Pressure (bar)	Pipeline Temperature	Potential Risk
1	Temporary Gas Pipeline	Leak of 25mm dia	41.36	24°C	Jet Fire
2	Temporary Gas Pipeline	Leak of 50mm dia	41.36	24°C	Jet Fire
3	Temporary Gas Pipeline	Complete rupture	41.36	24°C	Jet Fire VCE

The pipeline failure risk scenarios have been modeled using ALOHA and interpreted in terms of Thermal Radiation Level of Concern (LOC) encompassing the following threshold values (measured in kilowatts per square meter) for natural gas (comprising of ~95% methane<sup>3</sup>) to create the default threat zones:

*Red: 10 kW/ (sq. m) -- potentially lethal within 60 sec;*

*Orange: 5 kW/ (sq. m) -- second-degree burns within 60 sec; and*

*Yellow: 2 kW/ (sq. m) -- pain within 60 sec.*

For vapour cloud explosion, the following threshold level of concern has been interpreted in terms of blast overpressure as specified below:

*Red: 8.0 psi – destruction of buildings;*

*Orange: 3.5 psi – serious injury likely; and*

<sup>3</sup> [https://www.naesb.org/pdf/wgg\\_bps100605w2.pdf](https://www.naesb.org/pdf/wgg_bps100605w2.pdf)

<http://www.google.co.in/url?sa=t&rct=j&q=&esrc=s&source=web&cd=18&ved=0ahUKEwjF7MiDttPRAhVCMi8KHd7aD6cQFghrMBE&url=http%3A%2F%2Fwww.springer.com%2Fcontent%2Fdocument%2Fdocument%2Fdownloaddocument%2F9781848828711-c1.pdf%3FSGWID%3D0-0-45-862344-p173918930&usq=AFQjCNEaJKlfYKI3fRUdi6xiRYeW-FJb2A>

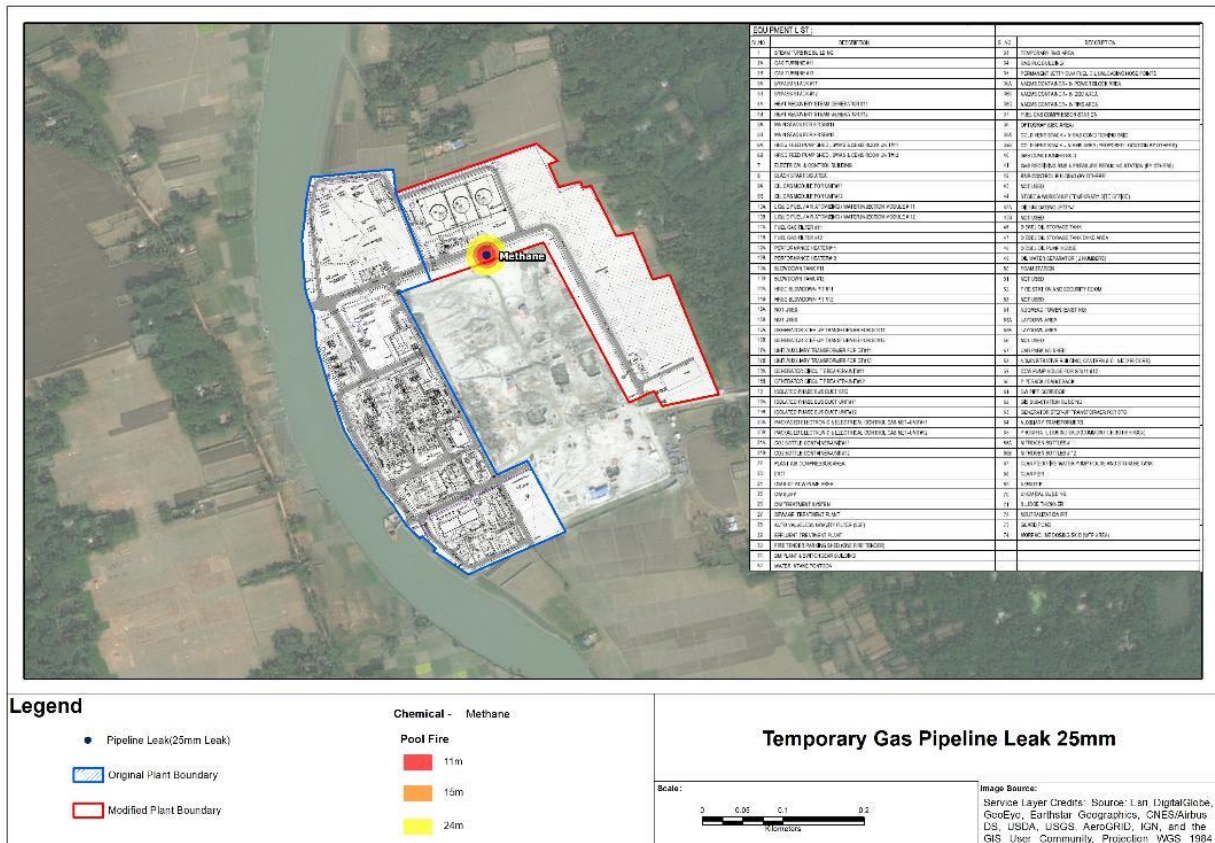
Yellow: 1.0 psi – shatters glass

The risk scenarios modelled for natural gas pipeline has been presented below

**Scenario 1: Temporary Gas Pipeline Leak (25mm dia)**

The jet fire threat zone plot for release and ignition of natural gas from pipeline leak of 25mm dia is represented in **Figure 5.8** below.

**Figure 5.8 Threat Zone Plot – Temporary Gas Pipeline Leak (25mm dia)**



Source: ALOHA

**THREAT ZONE:**

Threat Modeled: Thermal radiation from jet fire

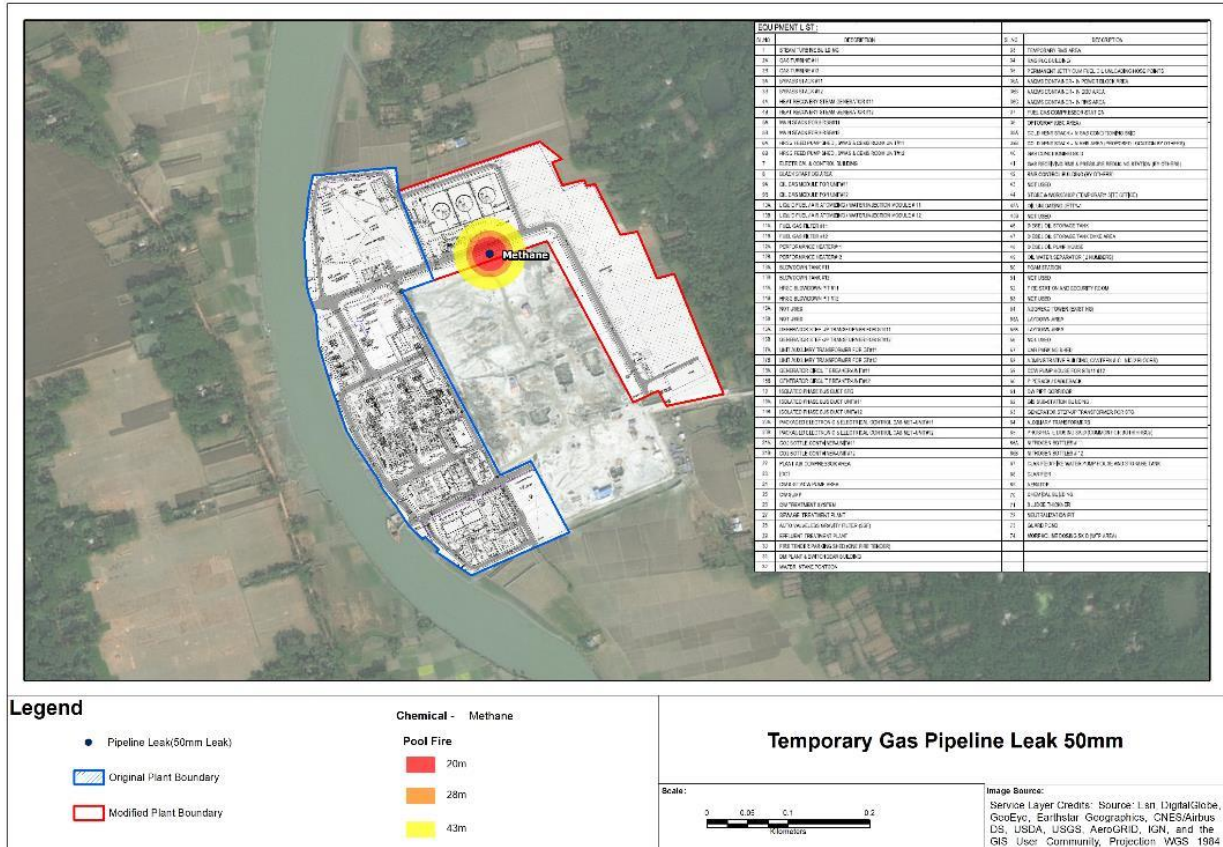
- Red : 11 meters --- (10.0 kW/ (sq. m) = potentially lethal within 60 sec)
- Orange: 15 meters --- (5.0 kW/ (sq. m) = 2nd degree burns within 60 sec)
- Yellow: 24 meters --- (2.0 kW/ (sq. m) = pain within 60 sec)

The worst hazard for release and ignition of natural gas from the pipeline leak of 25mm dia will be experienced to a maximum radial distance of 11m from the source with potential lethal effects within 1 minute.

Scenario 2: Temporary Gas Pipeline Leak (50mm dia)

The jet fire threat zone plot for release and ignition of natural gas from pipeline leak of 50mm dia is represented in **Figure 5.9** below.

**Figure 5.9 Threat Zone Plot – Temporary Gas Pipeline Leak (50mm dia)**



Source: ALOHA

**THREAT ZONE:**

Threat Modeled: Thermal radiation from jet fire

Red : 20 meters --- (10.0 kW/ (sq. m) = potentially lethal within 60 sec)

Orange: 28 meters --- (5.0 kW/ (sq. m) = 2nd degree burns within 60 sec)

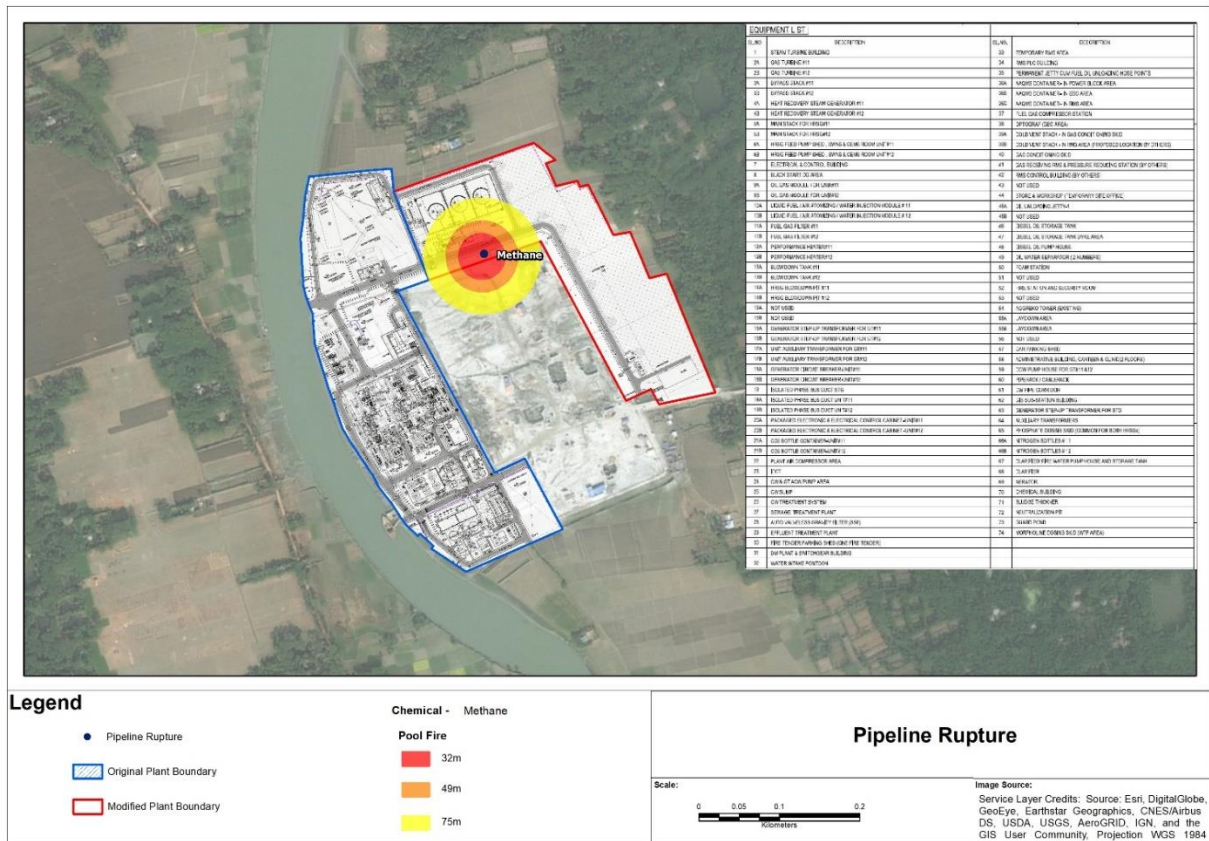
Yellow: 43 meters --- (2.0 kW/ (sq. m) = pain within 60 sec)

The worst hazard for release and ignition of natural gas from the pipeline leak of 50mm dia will be experienced to a maximum radial distance of 20m from the source with potential lethal effects within 1 minute.

### Scenario 3: Temporary Gas Pipeline Rupture

The jet fire threat zone plot for release and ignition of natural gas from pipeline rupture (worst case) is represented in **Figure 5.10** below.

**Figure 5.10 Threat Zone Plot – Temporary Gas Pipeline Rupture**



Source: ALOHA

### THREAT ZONE:

Threat Modeled: Thermal radiation from jet fire

Red : 32 meters --- (10.0 kW/ (sq. m) = potentially lethal within 60 sec)

Orange: 48 meters --- (5.0 kW/ (sq. m) = 2nd degree burns within 60 sec)

Yellow: 75 meters --- (2.0 kW/ (sq. m) = pain within 60 sec)

The worst hazard for release and ignition of natural gas from the pipeline rupture will be experienced to a maximum radial distance of 32m from the source with potential lethal effects within 1 minute. Superimposing the risk contours for the said worst case scenario on the site layout indicates the following project structures to be falling within the potential risk zones – **NBBL: foam station, oil-water separator, bulk diesel storage tanks and Bhola-I: RMS and Switchyard.**

For VCE modelled for catastrophic failure of natural gas pipeline onsite, the LOC level was never exceeded

### THREAT ZONE:

Threat Modeled: Overpressure (blast force) from vapor cloud explosion

Type of Ignition: ignited by spark or flame

Level of Congestion: uncongested

Model Run: Heavy Gas

Red : LOC was never exceeded --- (8.0 psi = destruction of buildings)

Orange: LOC was never exceeded --- (3.5 psi = serious injury likely)

Yellow: LOC was never exceeded --- (1.0 psi = shatters glass)

For calculating the risk significance of natural gas pipeline, the likelihood ranking is considered to be “2” as the probability of pipeline rupture is computed to be  $\sim 3.81 \times 10^{-5}$  per year; whereas the consequence ranking has been identified to be as “4” as given for a worst case scenario (rupture) lethal effects is likely to be limited within a radial zone of  $\sim 32$ m. Also no social sensitivities in the form of village settlements, educational institutions etc. were found to be located within this zone. Reportedly, adequate number of gas leak and fire detection system of appropriate design will be provided for the pipeline supply of natural gas to prevent for any major risk at an early stage of the incident.

*Risk Ranking – Temporary Gas Pipeline Rupture (Worst Case Scenario)*

<b>Likelihood ranking</b>	<b>2</b>	<b>Consequence ranking</b>	<b>3</b>
<b>Risk Ranking &amp; Significance = 6 i.e. “Low” i.e. Risk is Acceptable and can be managed through use of existing controls and evaluation of additional controls.</b>			

## 5.7 Additional Mitigation Measures for CID

In the earlier section, modelling of potential risks resulting from the CID related to diesel storage and operation of the temporary RMS and natural gas pipeline is found to be primarily limited within the site itself, except for the worst case scenario associated with diesel storage failure where few hutments located abutting the eastern boundary were found to be falling within the low risk zone (yellow), Hence in view of this, in addition to the mitigation measure proposed in the earlier ESIA report, NBBL to communicate the project related emergency situations and response measures to abutting community settlements falling within the said risk zones. Furthermore, the following measures specified below is required to be implemented as proposed by SGCL and Petrobangla:

- Obtain necessary approval from Department of Explosives, Bangladesh for revision in the earlier approved diesel storage layout.
- Regulator must be Low Differential type. There must have an off-take in the Inlet of Booster Compressor for internal pipeline from Permanent RMS.
- All pipe, equipment, valves and fittings of RMS from inlet to delivery point must be 300 class rating or equivalent as applicable.
- Construction/fabrication of temporary RMS and pipeline works shall be carried out by a 1.4 category contractor enlisted with Petrobangla or its subsidiary companies having minimum experience in construction/fabrication of similar RMS and Pipeline.
- Obtain permission from the Chief Inspector, Explosive Department, EMRD, Bangladesh for the temporary RMS and 300m gas pipeline length.
- Natural Gas Safety Rules-1991 (Revised-2003) and related applicable codes, standards governing in Bangladesh shall be followed.

## 6. STAKEHOLDER CONSULTATION AND PARTICIPATION

### 6.1 Introduction

This section identifies and profiles the key stakeholders for the procurement of the additional land for the Gas based Combined Cycle Power Plant Project (CCPP), Bhola and assesses their potential concerns and levels of influence. A participatory approach for consultation have been undertaken for stakeholder consultation. The main objective of the consultation is to ascertain the extend of impact for the addendum 17.41 acres of land parcel procures for the Main Plant and Laydown area.

### 6.2 Stakeholder Mapping and Analysis

“Stakeholder mapping” is a process of examining the relative influence that different individuals and groups have over a project as well as the influence of the project over them. The purpose of a stakeholder mapping is to;

- Study the profile of the stakeholders identified and the nature of the stakes;
- Understand each group’s specific issues, concerns as well as expectations from the project that each group retains;
- Gauge their influence on the project.

On the basis of such an understanding, the stakeholders are categorized into High Influence/ Priority, Medium Influence/ Priority and Low Influence/ Priority. The stakeholders who are categorized as high influence are those who have a high influence over the project or are likely to be heavily impacted by the project activities, and are thus high up on the project proponent’s priority list for engagement and consultation.

Similarly, the stakeholders categorized as medium influence are those who have a moderate influence over the project or even though they are to be impacted by the project, it is unlikely to be substantial and these stakeholders are thus neither high nor low in the project proponent’s list for engagement.

On the other hand, the stakeholders with low influences are those who have a minimal influence on the decision making process or are to be minimally impacted by the project and are thus low in the project proponent’s engagement list.

**Figure 6.1 Photographs of Stakeholder Consultation**



Consultation with titleholders at village Choto Monika on 25<sup>th</sup> September 2019



Consultation with titleholders at village Chor Gazipur on 25<sup>th</sup> September 2019



Consultation with local shopkeepers adjacent to NBBL project Site on 26<sup>th</sup> September 2019



Consultation with titleholders at Kutuba Union on 26<sup>th</sup> September 2019

### 6.3 Stakeholder Consultation for Additional Land

ERM undertook consultations with identified stakeholders during site visit. The key points discussed with each of these stakeholders are provided in **Table 6.1**:



**Table 6.1 Stakeholders and Key Points Discussed**

S. No.	Stakeholder Category	Key Points Discussed	Outcomes in brief	Rating
1.	Land sellers	<ul style="list-style-type: none"> <li>■ Issues/ grievances with respect to the land purchase process;</li> <li>■ Compensation</li> <li>■ Community perception towards the project</li> <li>■ Socio-economic condition of the people inhabiting the study area.</li> </ul>	<ul style="list-style-type: none"> <li>■ Consultation was carried out with some land owners at Kutuba, Chota Monika and Chor Gazipur mouza whose land was acquired.</li> <li>■ Locals mainly engaged in agriculture.</li> <li>■ Most of the land owners received the compensation in 2018 and also additional amount in 2019.</li> <li>■ The agricultural pattern practiced in the area primarily comprises of two season cropping pattern in low lying area and three season cropping pattern in higher grounds.</li> <li>■ It was revealed during discussion that 56% of land was cultivated by the titleholders alone and 43% by sharecroppers.</li> <li>■ As per the discussions undertaken with the landowners, it was noted that negotiated settlement was not part of the land purchase process. An amount BDT 20,000/- per decimal was offered to all landowners and accordingly based on this rate, land was purchased for the Main Plant and Laydown areas.</li> <li>■ The landowners confirmed that the entire amount they received in cash. However, they did not get compensation for the fruit bearing trees that were on their land.</li> <li>■ Apart from this in 2019 additional amount of three times of BDT 12,313 per decimal land was received. The BDT 12,313 was the average mouza rate per decimal at Borhanuddion Sub-Registry office.</li> </ul>	High

S. No.	Stakeholder Category	Key Points Discussed	Outcomes in brief	Rating
			<p><b>A Sample:</b>  <i>Name of Land Seller- Smt. Nafisha Begum,  Mouza- Chota Monika of Bhola District  Union- Kutuba  JL No-42/43  Total Land- 28 Decimals  Total Amount Received in 2017- 5,60,000 BDT @ 20,000 BDT per decimal rate  Additional Amount Received- 4,74,292 BDT</i></p> <p><i>(As per calculation the person is eligible to receive total 10,34,292 BDT @ 3 times of 12,313 BDT (Average land mouza rate of 2019) per decimal. She has already received BDT 5,60,000. So additional BDT 4,74,292 payment to be made.)</i></p> <ul style="list-style-type: none"> <li>■ It was informed that the land sellers have received the land price as per the three time of Mouza rate.</li> <li>■ Some people additionally bought better quality of land with the compensation money.</li> <li>■ Some land sellers invested the compensation amount for start-up of businesses like establishment of shop, poultry business, animal husbandry etc.</li> <li>■ As discussed with Mredha Families at Chor Gazipur mouza that they have received compensation for the CCP Project, Bhola. An elderly person of Mredha family says erosion and inundation has aggravated in the recent past. Most of their land washed away due to flood and erosion of Tetulia river. Presently they don't have any land left.</li> </ul>	
2	Sharecroppers and	<ul style="list-style-type: none"> <li>■ Community perception towards the project</li> </ul>	<ul style="list-style-type: none"> <li>■ Consultation was carried out with 6-7 sharecroppers and Agricultural labours.</li> </ul>	Low

S. No.	Stakeholder Category	Key Points Discussed	Outcomes in brief	Rating
	Agricultural labours	<ul style="list-style-type: none"> <li>■ Socio-economic condition of the people inhabiting the study area</li> <li>■ Compensation for the crops</li> </ul>	<ul style="list-style-type: none"> <li>■ The contract for undertaking sharecropping is for a period of one year which is renewed periodically. In the project area, primarily two season crops are cultivated. Three season crops are cultivated on higher areas in Kutuba however it is practiced on a smaller scale.</li> <li>■ Mostly they cultivate for their own consumption</li> <li>■ It was revealed from the discussion that around 20-30 sharecroppers were working on the land area purchased for the project impacted due to land procurement for the power plant.</li> <li>■ The lease for one year is BDT 400 for 4 decimal for a year. One sharecropper used to undertake agricultural activities in 4 decimal land area.</li> <li>■ In two season cropping pattern, amun and aush rice are cultivated and in three season cropping pattern, amun, aush and pulses are cultivated. In between pulses, vegetables such as pui saag, palak saag, bottle gourd, bitter gourd, ridge gourd, brinjal and chillies are cultivated.</li> <li>■ Compensation for the crops was not provided to the sharecroppers.</li> <li>■ Three agricultural labourers per day is used for one season and in a year on average 72 labourers are used. The daily wage of agricultural labourers is BDT 500-550 per day.</li> <li>■ With the purchase of land for the project, some agricultural labourers have changed their profession and become construction labourers including assisting carpenter, painters and electricians.</li> <li>■ The land area to do sharecropping has decreased. Sharecropping is practiced primarily in Ward No 6 of Kutuba Union which is at the opposite bank of Dehular Canal that is out of project area.</li> </ul>	
3.	NBBL	<ul style="list-style-type: none"> <li>■ Land requirement for the project</li> </ul>	<ul style="list-style-type: none"> <li>■ Total number of land seller, who sold their land for the project is 126.</li> </ul>	High

S. No.	Stakeholder Category	Key Points Discussed	Outcomes in brief	Rating
		<ul style="list-style-type: none"> <li>■ No of land owner</li> <li>■ Status of land procurement</li> <li>■ Land purchase process</li> <li>■ Land Compensation</li> <li>■ Circle price of land</li> </ul>	<ul style="list-style-type: none"> <li>■ Land purchase was based on negotiated settlement and was based on willing buyer and willing seller</li> <li>■ The land procurement for the NBBL plant commenced in December 2016 with the use of land consolidators.</li> <li>■ The rate of the land which was BDT 20,000 per decimal was apparently pre-determined. This rate was adopted for all land procured for NBBL from 2016 to 2019 excluding the gas pipeline. It was reported by the land sellers that the project proponent informed the land sellers that the land procurement was for the power plant. All land sellers confirmed that they received the compensation at BDT 20,000 per decimal, in cash from Revenue Office Representative. No commission for sale of land, sale tax, and land registration was charged from the land sellers, reportedly.</li> <li>■ The RAP &amp; LRDP Report prepared in May 2018 and a review of the report was undertaken in Quarterly Audit Monitoring Report as requirement of AIIB (Asian Infrastructure Investment Bank) ESP. Based on the LRP report a separate LRP budget was developed to take into account the loss of livelihood of the affected population.</li> <li>■ Based on the requirement of LRP, the compensation amount was determined at three times of BDT 12,313 per decimal in addition to the amount already disbursed by NBBL.</li> </ul>	

## 7. ADDENDUM ENVIRONMENTAL AND SOCIAL MANAGEMENT PLAN

### 7.1 Introduction

NBBL has prepared the Environment and Social Management Plan (ESMP) under ESIA study finalised during 2018. ESMP has been implemented by three EPC contractors under NBBL. However, NBBL has procured additional land for project and modified the design. Due to these changes, NBBL is now conducting Addendum ESIA study. Under this ESIA study some additional mitigation measures has been proposed. The addendum ESMP has been developed with an aim to avoid, reduce, mitigate, or compensate for adverse environmental and social impacts/risks and to propose enhancement measures. This includes:

- mitigation of potentially adverse impacts;
- monitoring of impacts and mitigation measures during different Project phases of implementation and operation;
- integration of the ESMP with Project planning, design, construction and operation;
- institutional capacity building and training; and
- Compliance to statutory requirements.

### 7.2 Mitigation Measures

Key environmental and social impacts have been identified and reported in **Chapter 4** along with mitigation measures. A summary of mitigation measures is presented in Table 7.1. This also identifies lead responsibility for implementing the mitigation measures and sources of funds for such implementation.

The ESMP is supported with the following framework management plans (Annex X):

- Appendix D: Oil Spill Response Plan;
- Appendix E: Livelihood Restoration and Development Plan.

**Table 7.1 Environmental and Ecological Management Plan of the Project**

S. No.	Affected Aspect	Project Activity /affected area	Potential Impacts	Proposed Mitigation Measures	Responsibility for Mitigation Implementation	Responsibility for supervision of mitigation implementation	Reporting Requirements	Approximate cost and Mitigation Cost Source
A.	Land Use due to procurement of additional land	<ul style="list-style-type: none"> <li>■ Additional land procured for main plant including laydown area.</li> <li>■ Land required for ROU of gas pipeline</li> </ul>	Loss of agricultural land	<ul style="list-style-type: none"> <li>■ Restrict the all the construction activity within the acquired land for plant</li> </ul>	Appointed EPC Contractor- Bisho Infra Project Ltd  SGCL for pipeline	On site Project Management team and designated HSE team	Monthly report to NBBL	EPC Contractor Cost
B.	Soil & sediment quality	<ul style="list-style-type: none"> <li>■ Surface runoff from construction site (additional area)</li> <li>■ Discharge of waste water from construction site</li> <li>■ Decommissioning of Construction jetty</li> </ul>	Impact on soil & sediment quality and subsequently on aquatic ecology	<p><u>Storage and handling fuel and chemicals:</u></p> <ul style="list-style-type: none"> <li>■ Fuel tanks and chemical storage areas will be sited on sealed areas and provided with locks to prevent unauthorized entry;</li> <li>■ Use of spill or drip trays to contain spills and leaks;</li> <li>■ Use of spill control kits to contain and clean small spills and leaks.</li> <li>■ The storage areas of oil, fuel and chemicals will be surrounded by bunds or other containment device to prevent spilled oil, fuel and chemicals from percolating into the ground or reaching the receiving waters;</li> <li>■ The construction contractor will implement a training program to familiarise staff with emergency procedures and practices related to contamination events.</li> </ul> <p><u>Waste handling and management:</u></p> <ul style="list-style-type: none"> <li>■ Design processes to prevent/minimise quantities of wastes generated and hazards associated with the waste generated;</li> <li>■ Training labourers for waste disposal in designated areas and use of sanitation facilities;</li> <li>■ Proper storage of the construction materials and wastes to minimise the potential damage or contamination of the materials; and</li> <li>■ Segregation of hazardous and non-hazardous waste and provision of appropriate containers for the type of waste type (e.g. enclosed bins for putrescible materials to avoid attracting pests and vermin and to minimise odour nuisance);</li> </ul>	Appointed EPC Contractor- Bisho Infra Project Ltd	On site Project Management team and designated HSE team	Monthly report to NBBL	EPC Contractor Cost

S. No.	Affected Aspect	Project Activity /affected area	Potential Impacts	Proposed Mitigation Measures	Responsibility for Mitigation Implementation	Responsibility for supervision of mitigation implementation	Reporting Requirements	Approximate cost and Mitigation Cost Source
				<ul style="list-style-type: none"> <li>Storage of hazardous wastes in closed containers away from direct sunlight, wind and rain;</li> <li>Storage of hazardous waste systematically to allow inspection between containers to monitor leaks or spills;</li> <li>Ensuring that storage areas have impermeable floors and containment, of capacity to accommodate 110% of the volume of the largest waste container for hazardous liquid wastes; and</li> <li>Disposal of waste through licensed contractors or in consultation with DoEn..</li> </ul> <p><u>Surface Runoff Mitigation measures</u></p> <ul style="list-style-type: none"> <li>Periodic cleaning will be undertaken of storm water drainage structures to maintain uninterrupted storm water flow.</li> <li>Sediment control measures in the form of silt traps and sedimentation tank will be provided to treat surface run-off before disposal.</li> <li>Oil water separator will be provided in the oil handling/ storage sites;</li> </ul> <p><u>Monitoring</u></p> <ul style="list-style-type: none"> <li>Periodical monitoring of soil &amp; sediment quality as per monitoring plan</li> </ul>				
C.	Surface Water Quality due to Thermal Discharge	<ul style="list-style-type: none"> <li>Discharge of cooling blowdown water.</li> </ul>	Impact on surface water quality, assessed to be	<ul style="list-style-type: none"> <li>Induced draft cooling system</li> <li>Temperature checks to be performed regularly before discharge of cooling blowdown from plant</li> </ul>	Operations and Plant HSE Team to implement O&M Phase Mitigation Measures	HSE department and Operations.  Study by 3 <sup>rd</sup> Party agency /experts.	Records maintained and Monthly internal reports to top management and reporting to regulatory authorities/ lenders as required.	Included in Project Capital and Plant O&M Cost as mentioned above
D.	Surface water quality and aquatic ecology due to oil spill	<ul style="list-style-type: none"> <li>Accidental discharge due to leakages of vessels and due to collision with other ships</li> </ul>	Potential to impact on surface water quality, mangrove vegetation and aquatic ecology including fishery	<p><u>Oil spill response action:</u></p> <p>Ensure the responsibility towards receiving, identifying and classifying notices of events which need immediate response and communicating this information to concerned project personnel and authorities for corrective action, as per oil spill response plan.</p> <p><u>Initial Oil Spill Notification</u></p>	Operations and Plant HSE Team and HSD supplier	HSE department and Operations.	Record keeping for minor and major oil spill incidents and report the incident to the Department of Environment, MoEF, Bangladesh Navy or Coast Guard, Bangladesh Inland Waterways Authority (BIWTA) and/or	NBBL

S. No.	Affected Aspect	Project Activity /affected area	Potential Impacts	Proposed Mitigation Measures	Responsibility for Mitigation Implementation	Responsibility for supervision of mitigation implementation	Reporting Requirements	Approximate cost and Mitigation Cost Source
				<p>In case of an offshore oil spill, the owner, captain or any person in charge of the transportation of fuel through barges shall immediately report the same to the NBBL. On receipt of the spill notification, NBBL shall immediately report the incident to the Department of Environment, MoEF, Bangladesh Navy or Coast Guard, Bangladesh Inland Waterways Authority (BIWTA) and/or nearest port authority, who have been identified as key stakeholders of the National Oil Spill Contingency Plan (NOSCP) of Bangladesh.</p> <p><u>Oil Spill – Hazard Assessment</u></p> <p>NBBL in liaison with the national agencies like BCG, BIWTA, must carry out a rapid initial assessment of the oil spill situation.</p> <p><u>Clean Up Actions</u></p> <p>Implement the clean-up action as suggested in the Oil spill management plan.</p>			nearest port authority	
E.	Community health & safety due change of HSD storage location	<p>Accidental release of HSD and fire from storage tank</p> <p>Accidental release and fire gas from temporary gas pipeline</p>	Community health and safety of the nearby community	<ul style="list-style-type: none"> <li>■ Obtain necessary approval from Department of Explosives, Bangladesh for revision in the earlier approved diesel storage layout.</li> <li>■ Regulator must be Low Differential type. There must have an off-take in the Inlet of Booster Compressor for internal pipeline from Permanent RMS.</li> <li>■ All pipe, equipment, valves and fittings of RMS from inlet to delivery point must be 300 class rating or equivalent as applicable.</li> <li>■ Construction/fabrication of temporary RMS and pipeline works shall be carried out by a 1.4 category contractor enlisted with Petrobangla or its subsidiary companies having minimum experience in construction/fabrication of similar RMS and Pipeline.</li> <li>■ Obtain permission from the Chief Inspector, Explosive Department, EMRD, Bangladesh for the temporary RMS and 300m gas pipeline length.</li> <li>■ Natural Gas Safety Rules-1991 (Revised-2003) and related applicable codes, standards governing in Bangladesh shall be followed</li> </ul>	Operations and Plant HSE Team to implement O&M Phase Mitigation Measures	HSE department and Operations.	Record keeping for any incidence	Included in Project Capital and Plant O&M Cost as mentioned above
F.	Livelihood due to Procurement of additional land	<ul style="list-style-type: none"> <li>• Procurement of additional land for power plant</li> </ul>	Impact of livelihood due procurement of additional land- land	<ul style="list-style-type: none"> <li>■ Engage the PAP in the project as per their skill</li> </ul>	NBBL	On site Project Management team and designated HSE team	Monthly report to NBBL	NBBL



S. No.	Affected Aspect	Project Activity /affected area	Potential Impacts	Proposed Mitigation Measures	Responsibility for Mitigation Implementation	Responsibility for supervision of mitigation implementation	Reporting Requirements	Approximate cost and Mitigation Cost Source
		<ul style="list-style-type: none"> <li>Procurement of land for RU of pipeline</li> </ul>	owners, land users	<ul style="list-style-type: none"> <li>LRDP should consider the livelihood opportunity; like                             <ul style="list-style-type: none"> <li>Skill improvement training,</li> <li>Planning and training for business</li> <li>Preference of local contractor to work under EPC contractor</li> </ul> </li> </ul>				

## 7.3 Environmental Management System

### 7.3.1 Commitments & Policies

It is to be noted that environmental and social sustainability is embedded in the Project Sponsor's (SPICCP) business decisions and processes through a Group level EHS&S Management System. Environment, Health & Safety and Social Policies of the company are presented in **Appendix F**. NBBL has also align with the requirements of the corporate policies and procedures and ensure that the environmental and social performance of the project is implemented concurrently. SPICCP is also having an Environmental and Social Management System (ESMS), which provides process and procedures for its project vertical. These will be applicable to NBBL, Bhola II power project as well.

### 7.3.2 ESMP Implementation: Roles and Responsibility

#### 7.3.2.1 Existing Organization Structure

The implementation of ESMP will largely remain with the E&S team. The institutional structure of the E&S team has been provided in **Figure 7.1**.

#### 7.3.2.2 Roles & Responsibility

The roles and responsibilities of the Project Developer (NBBL) and EPC Contractor has been provided below:

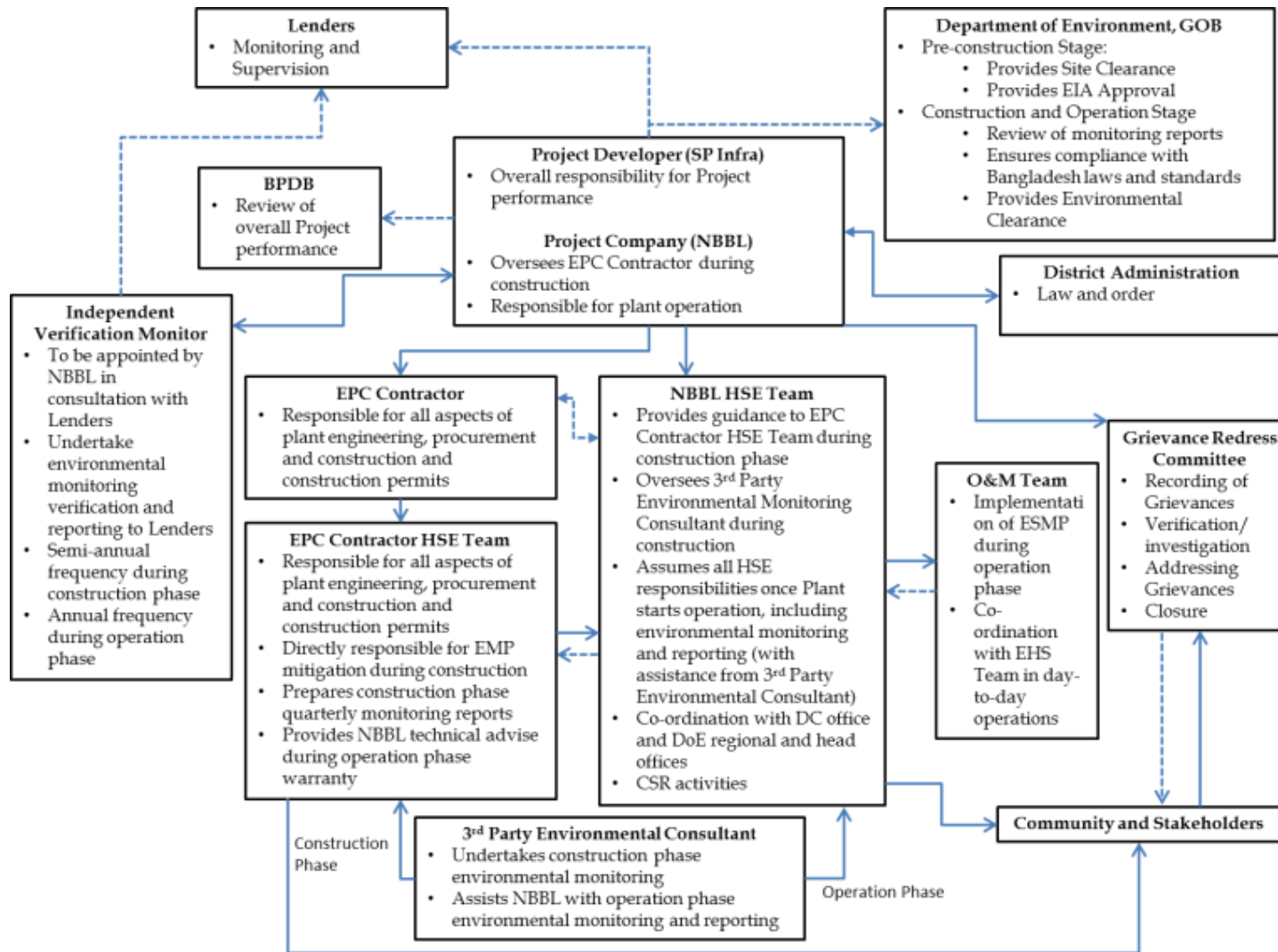
##### *Project Developer (NBBL)*

- Obtaining statutory clearances required during pre-construction stage of the Project
- Overall project co-ordination and management through EPC and supported by the third party environmental consultant/s
- Interaction and reporting to the respective department of GOB
- Interaction and reporting to lenders
- Effective implementation of ESMP and monitoring of ESMP implementation
- Carryout verification/ supervision exercises during the construction phase of the Project for implementation of ESMP
- Keeping records of all permits obtained by EPC Contractor
- Overall supervision of ESMP implementation
- Implementation and monitoring of LRDP
- Approval of plans prepared by EPC Contractor
- Addressing grievances of local community and information dissemination
- Environmental monitoring through laboratory.

##### *EPC Contractor*

- Obtaining permits required during the construction stage
- Joint verification with Project Developer and Third Party Environmental Consultant for review of ESMP implementation
- Interaction with Project Developer and appointed supervision consultant, if any
- Filling of reporting formats as per the reporting schedule and submission to Project Developer
- Environmental monitoring through Third Party Environmental Laboratory
- Preparation of various plans for effective implementation of ESMP as detailed out in the "Specification Manual" by the Project Developer.

**Figure 7.1 Organogram Structure of NBBL for Construction and Operation Phase of the Project**



Source ESIA Report 2018

## 7.4 ESMP Monitoring & Audit

### 7.4.1 Introduction

This section outlines the processes of monitoring and audit associated with the ESMP. These processes are necessary in order to:

- Verify and document the due implementation of, and in some cases the effectiveness of, management and mitigation measures identified the ESMP
- Monitor and document the effectiveness of management and mitigation measures and assess actual impacts
- Demonstrate compliance with applicable legal and other requirements
- Evaluate the implementation and effectiveness of the environmental and social program.

### 7.4.2 Monitoring

The ESMP monitoring programme has been devised with the following objectives:

- To evaluate the effectiveness of the proposed mitigation measures proposed in the ESMP;
- To identify the need for improvements in the ESMPs;
- To verify compliance with statutory and community obligations; and
- To allow comparison against baseline conditions and assess the changes in environmental quality in the Project AOI.

### 7.4.3 Audit

NBBL may undertake environmental and social audits, at its discretion, of Contractor and subcontractor activities and work sites. Such audits will be undertaken in accordance with predetermined protocols agreed with Contractor.

The Independent Environmental and Social Consultant (IESC) will, on behalf of the Lender Group, undertake periodic environmental and social audits of Project activities and work sites. Such audits will be undertaken in accordance with a predetermined protocol to be agreed with Company. Company, Contractors and subcontractors shall cooperate fully with the IESC in the execution of audits. Upon completion of the audits, the IESC will provide Company and Lender Group with a draft audit report. The audit report will be discussed between the IESC, Company and Lender Group, following which the IESC will provide Company with a final audit report.

### 7.4.4 Performance Indicators & Management Review

Physical, biological and social environmental management components of particular significance have been identified as performance indicators. A comprehensive monitoring plan for each E&S performance indicator has been prepared for Project and is presented in **Table 7.2**. This includes parameters to be measured, methods to be used, sampling locations, frequency of measurements, detection limits, cost and responsibilities for implementation and supervision.

**Table 7.2 ESMP Monitoring Programme**

ESMP Action Item	Parameters to be Monitored	Location	Frequency	Responsibility	Key Performance Indicator
<b>Land Use due to procurement of additional land</b>					
Restrict the all the construction activity within the acquired land for plant	Any construction activity outside the designated area	Construction area	Monthly	EPC contractor	No public complain
Immediate site restoration along the pipeline corridor	Restoration time taken for segments of pipeline section	Pipeline ROU	Monthly	SGCL	No public complain
<b>Soil &amp; sediment quality</b>					
Appropriate HSD and chemical storage facility- paved surface, secondary containment, spill kit	Storage facility as per approved plan	HSD and other fuels for construction stage, chemicals storage area	Monthly	EPC contractor during construction stage and NBBL during operational phase	Facility as per approved plan
Demarcated waste storage facility, disposal as per GOB guidelines	Storage facility as per approved plan	Waste storage area	Monthly	EPC contractor during construction stage and NBBL during operational phase	Facility as per approved plan
Surface runoff control measures	Surface runoff drainage system and sedimentation tank and oil-water separator and its performance	Drainage system and discharge point	Monthly	EPC contractor during construction stage and NBBL during operational phase	Effectiveness of treatment system

ESMP Action Item	Parameters to be Monitored	Location	Frequency	Responsibility	Key Performance Indicator
Soil and sediment quality monitoring	Soil and sediment quality as suggested in the ESIA 2018	For soil- there location around the plant. For sediment- five locations in the Kohelia River	Pre and Post Monsoon.	EPC contractor during construction stage and NBBL during operational phase	Comparing the baseline quality of soil & sediment
<b>Thermal Discharge</b>					
Discharge of return cold water from the FSRU and machine cooling water	Volume and temperature of cooling blowdown water	Discharge point	Daily	O&M Contractor	Volume & temperature as mentioned in the design report
<b>Surface water quality and aquatic ecology due to oil spill</b>					
Arrangement of Oil spill Containment & Recovery devices including boom and skimmers,	Arrangement of devised as per oil spill management plan	NBBL Oil Spill response centre	Quarterly	Oil spill response team	Devices as per plan
Oil spill reporting	Volume of spill and location	Spillage area	At the time of incidence	Oil spill response team	Reporting of all incidence
Clean Up Actions	Clean-up of spilled oil in the affected area	Spillage area and affected area	At the time of incidence	Oil spill response team	Satisfactory cleaning activity
<b>Community health &amp; safety due change of HSD storage location</b>					
Necessary approval from concerned authority and incorporation of safety design	Approval and implement the design parameter	HSD storage tank area and temporary pipeline area	During construction phase	EPC contractor	Compliance with design parameter
<b>Livelihood due to Procurement of additional land</b>					
Livelihood enhancement programme	Implementation status of livelihood enhancement program	PAF	Quarterly	NBBL	Implementation as per plan
Livelihood program for land users	Implementation status of livelihood enhancement program	PAF	Quarterly	NBBL	Implementation as per plan

### **7.4.5 Reporting**

The reporting system will provide the Project with the necessary feedback mechanisms to ensure quality and timely implementation of the works. The reporting system will ensure regular flows of information from the Project site to the Project headquarters and, as necessary, to regulatory authorities and funding agencies. The reporting system will provide a mechanism for ensuring that the measures proposed in the Project's ESMP are implemented.

### **7.4.6 Contractor Monitoring Reporting**

Contractors shall provide to Company a monthly Environmental and Social Report. Contractors shall work closely with Company prior to commencement of work to define the structure, content and format of the monthly Report, however as a minimum, the report shall contain the following information:

- Details of preconstruction environmental surveys undertaken by Contractor in the reporting period (see ESMP) and additional management and mitigations arising where applicable
- Details of environmental monitoring (sampling and analysis) and social monitoring undertaken by Contractor during the reporting period (see performance indicator & management)
- Reporting of Company required Performance Indicators applicable during the reporting period
- Reporting of additional environmental and social performance indicators applicable during the reporting period
- Summary and copies of notifications and other reports made by Contractor to Government agencies
- Summary and status of Non Conformances and Field Observations documented as part of Contractors' verification and monitoring
- Assessment and audit reports and summary and status

### **7.4.7 Company Monitoring Reporting**

The quarterly reports of the management measures will form an integral part of the Quarterly Progress Reports that can be submitted to the lenders. Additional compliance reports to the Regional Office and Head Office of the DOE required as a part of environmental clearance process shall also be prepared and submitted based on the necessary monitoring and reporting formats.

The structure, content and format of the monitoring report will be agreed with lenders/DOE prior to commencement of work, however as a minimum the report will contain the following information:

- Details of preconstruction environmental surveys undertaken by Contractor in the reporting period (see ESMP) and additional management and mitigations arising where applicable
- Details of stakeholder Engagement activities undertaken during the reporting period
- Reporting of environmental and social performance indicators applicable during the reporting period
- Summary of verification, monitoring, assessment and audits undertaken during the reporting period.
- Summary of grievance management (workers grievances and community grievances) applicable during the reporting period
- Summary of public consultation and disclosure activities applicable during the reporting period.

### 7.4.8 Reporting Requirement

The reporting requirement for additional studies has been defined in the following Table:

**Table 7.3 SLNG Reporting Requirement**

Reporting Responsibility	Existing Requirement	As per additional ESMP
Contractor & Subcontractor	Not specified/ required	Every month
Corporate E & S Team	Every three months	Every three months
External Auditor	Every six month	Every six months

### Review of Clearances, Approvals and Permits

EIA approval for the Project was issued by Department of Environment (DOE), Government of Bangladesh (GOB), vide letter dated 20th April 2017, which was valid for 1 year till 19th April 2018. Subsequently NBBL has applied for renewal and DOE, GOB has issued EIA approval on 31st January 2018 which was valid for one year till 30th January 2019. Thereafter NBBL has applied for renewal of EIA approval on 20th December 2018 and received approval on 10th March 2019 which is valid till 28th February 2020.

NBBL has modified the site layout plan, which includes the procurement of additional land (11.645 acres), shifting of HSD storage area and temporary gas connection from Bhola I plant. Considering these modification, NBBL should amend the EC as per revised plan.

### 7.4.9 Training, Awareness and Competency

This section provides a summary of training, awareness and competency requirements associated with the ESMP.

Contractors shall ensure that all Contractor and subcontractor personnel responsible for the execution of the tasks and requirements contained within this ESMP and Contractor ESMP documents are competent on the basis of education, training and experience. Company will equally ensure that all Company personnel are competent on the basis of education, training and experience.

Contractor's ESMP shall describe the training and awareness requirements necessary for its effective implementation. Contractor's training, awareness and competency program, including delivery and verification thereof, is subject to Company review and approval.

Company, Contractors and subcontractors shall provide personnel with environmental and social training appropriate to their scope of activity and level of responsibility. Focused training shall be undertaken to ensure that all personnel are fully conversant with the aspects of this ESMP and Contractor/subcontractor ESMP documents which are relevant to their duties.

Company, Contractors and subcontractors shall appropriately document the environmental and social training activity by means of a training needs assessment, training matrix/plan and records of training undertaken.

### 7.4.10 Stakeholder Engagement

NBBL has developed the project-specific Stakeholder Engagement Plan which was currently implemented by NBBL. Same plan will be followed.



## 7.5 ESMP Budget

Budgetary estimates for additional environmental and social management for the NBBL project includes items envisaged as part of the ESMP. These have been worked out based on details and specifications for mitigation measures. The ESMP budget includes provisions for environmental management and monitoring (other than measures considered under good engineering practices or those integrated as embedded project controls). The ESMP budget is as follows:

**Table 7.4 ESMP Budget**

Component	Details	Amount
Soil & sediment quality	HSD, chemical storage facility with secondary containment and spill control equipment	Included in EPC contractor budget
	Hazardous and non-hazardous storage facility with secondary containment and spill control equipment	Included in EPC contractor budget
	Surface runoff control measures	Included in EPC contractor budget
Thermal Discharge Modelling	Volume and temperature of cooling blowdown water	Plant operation and maintenance budget
Surface water quality and aquatic ecology due to oil spill	Oil spill management plan	Budget has been provided in oil spill management plan
Community health & safety due change of HSD storage location	Safety measures and DMP	Plant operation and maintenance budget
Livelihood due to Procurement of additional land	LRDP for PAF including land owners and land users and common villagers (CSR plan)	As per LRDP plan
Land Access Restriction	Alternative site access road	Included in EPC contractor budget

## APPENDIX A      SEDIMENT QUALITY MONITORING REPORT

## APPENDIX B      FISHERY STUDY REPORT

## APPENDIX C      THERMAL DISCHARGE MODELLING REPORT

## APPENDIX D OIL SPILL RESPONSE PLAN

## APPENDIX E      LRDP

## APPENDIX F      EHS POLICY









---

**ERM has over 160 offices across the following countries and territories worldwide**

Argentina	New Zealand
Australia	Panama
Belgium	Peru
Brazil	Poland
Canada	Portugal
China	Puerto Rico
Colombia	Romania
France	Russia
Germany	Singapore
Hong Kong	South Africa
Hungary	South Korea
India	Spain
Indonesia	Sweden
Ireland	Taiwan
Italy	Thailand
Japan	UAE
Kazakhstan	UK
Kenya	US
Malaysia	Vietnam
Mexico	
The Netherlands	

**ERM India Private Limited**

4<sup>th</sup> Floor, Building 10A,  
DLF Cyber City,  
Gurgaon – 122002 | India

T: +91 124 4170 300

[www.erm.com](http://www.erm.com)