

**Nutan Bidyut (Bangladesh) Limited**  
[a subsidiary of Shapoorji Pallonji  
Infrastructure Capital Company Pvt. Ltd.]

# Environmental and Social Impact Assessment of 225 MW Dual Fuel (Gas and HSD based) Combined Cycle Power Plant (Bhola-II): *Burhanuddin, Bhola District, Bangladesh*

**Updated Final Report**

January 2018

[www.erm.com](http://www.erm.com)

Nutan Bidyut (Bangladesh) Limited

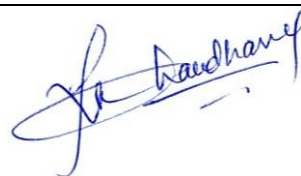
Environmental and Social Impact Assessment of  
225 MW Dual Fuel (Gas and HSD based)  
Combined Cycle Power Plant (Bhola-II):  
*Burhanuddin, Bhola District, Bangladesh*

9 January 2018

Reference # 0345133

---

Reviewed by: **Naval Chaudhary**  
*Principal  
Consultant*



---

**Rutuja Tendolkar**  
*Principal  
Consultant*



---

Approved by: **Neena Singh**  
*Partner*



---

This report has been prepared by ERM India Private Limited a member of Environmental Resources Management Group of companies, with all reasonable skill, care and diligence within the terms of the Contract with the client, incorporating our General Terms and Conditions of Business and taking account of the resources devoted to it by agreement with the client.

We disclaim any responsibility to the client and others in respect of any matters outside the scope of the above.

This report is confidential to the client and we accept no responsibility of whatsoever nature to third parties to whom this report, or any part thereof, is made known. Any such party relies on the report at their own risk.

## CONTENTS

0	EXECUTIVE SUMMARY	I
0.1	INTRODUCTION AND BACKGROUND	I
0.2	PROJECT ALTERNATIVES	V
0.3	PROJECT AREA OF INFLUENCE	VI
0.4	KEY IMPACTS FOR DECISION MAKING	XV
0.5	PROJECT BENEFITS	XXIII
0.6	ENVIRONMENTAL AND SOCIAL MANAGEMENT PLAN	XXIII
0.7	STAKEHOLDER ENGAGEMENT	XXIV
0.8	CONCLUSION	XXVII
1	INTRODUCTION	1-1
1.1	INTRODUCTION	1-1
1.2	OVERVIEW OF THE PROJECT	1-1
1.2.1	<i>Need for the Project</i>	1-1
1.2.2	<i>Project Background</i>	1-2
1.2.3	<i>The Project - Bhola II</i>	1-2
1.3	ABOUT THE PROJECT COMPANY AND SHAREHOLDERS	1-3
1.3.1	<i>The Project Company - Nutan Bidyut (Bangladesh) Limited</i>	1-3
1.3.2	<i>Parent Company - SP Infra</i>	1-4
1.3.3	<i>Shapoorji Paloondi Group - Sustainable Development Strategy</i>	1-6
1.4	IMPACT ASSESSMENT OBJECTIVES	1-6
1.5	SCOPE OF EIA STUDY	1-7
1.5.1	<i>Applicable Reference Framework</i>	1-7
1.5.2	<i>Coverage of EIA Study</i>	1-7
1.5.3	<i>Scope of Work</i>	1-8
1.6	APPROACH AND METHODOLOGY	1-8
1.6.1	<i>Screening</i>	1-9
1.6.2	<i>Scoping</i>	1-9
1.6.3	<i>Baseline Data Generation</i>	1-11
1.6.4	<i>Impact Assessment and Management</i>	1-12
1.7	ESIA TEAM	1-12
1.8	REPORT STRUCTURE	1-13
2	POLICY, LEGAL AND ADMINISTRATIVE FRAMEWORK	2-1
2.1	INTRODUCTION	2-1
2.2	ENVIRONMENT-RELATED POLICIES IN BANGLADESH	2-1
2.2.1	<i>National Environmental Policy, 1992</i>	2-1
2.2.2	<i>National Environment Management Action Plan, 1995</i>	2-2
2.2.3	<i>National Conservation Strategy, 1992</i>	2-3
2.2.4	<i>Other Policies relevant to Environment</i>	2-3
2.3	ENVIRONMENT AND SOCIAL RELATED LEGISLATIONS IN BANGLADESH	2-5
2.3.1	<i>The Environment Conservation Act, 1995 (subsequent amendments in 2000, 2002 and 2010)</i>	2-5
2.3.2	<i>Environment Conservation Rules (ECR), 1997 (subsequent amendments in 2002, 2003 and 2010)</i>	2-5

2.3.3	<i>Water Act, 2013</i>	2-6
2.3.4	<i>Acquisition and Requisition of Immovable Property Ordinance, 1982</i>	2-6
2.3.5	<i>Administrative and Regulatory Guidelines and Instructions</i>	2-7
2.3.6	<i>Other Relevant National Legal Instruments for the Project</i>	2-8
2.4	ADMINISTRATIVE SETUP RELATED TO ENVIRONMENT IN BANGLADESH	2-14
2.4.2	<i>Department of Environment (DOE)</i>	2-14
2.4.3	<i>Status of Project Approval from DOE</i>	2-18
2.5	INSTITUTIONAL ARRANGEMENTS RELATED TO LAND ACQUISITION IN BANGLADESH	2-18
2.6	RELEVANT INTERNATIONAL TREATIES AND CONVENTIONS	2-19
2.7	INTERNATIONAL SAFEGUARD REQUIREMENTS	2-21
2.7.1	<i>IFC Performance Standards</i>	2-21
2.7.2	<i>IFC Project Categorization</i>	2-28
2.7.3	<i>IFC EHS Guidelines</i>	2-29
2.7.4	<i>ADB's Safeguard Policy Statement, 2009</i>	2-29
2.7.5	<i>ADB Project Categorisation</i>	2-31
2.7.6	<i>Equator Principles, 2013</i>	2-33
2.7.7	<i>AIIB Environmental and Social Framework</i>	2-36
2.8	PROJECT CLASSIFICATION AND CATEGORISATION	2-40
2.8.1	<i>DOE, Ministry of Environment and Forest, Bangladesh</i>	2-40
2.8.2	<i>Project Classification as per ADB Safeguard Policy Statement and AIIB ESS2-40</i>	
2.8.3	<i>Project Classification as per IFC Performance Standards</i>	2-43
2.9	APPLICABLE EHS STANDARDS	2-43
2.10	APPLICABLE ENVIRONMENTAL STANDARDS BOTH NATIONAL AND INTERNATIONAL	2-44
3	PROJECT DESCRIPTION	3-1
3.1	PRELUDE	3-1
3.2	LOCATION	3-1
3.3	KEY FEATURES OF THE SITE AND SURROUNDINGS	3-5
3.4	PLANT CONFIGURATION	3-7
3.4.1	<i>Gas Turbine</i>	3-7
3.4.2	<i>Heat Recovery Steam Generator</i>	3-7
3.4.3	<i>Steam Turbine</i>	3-7
3.4.4	<i>Feed Water System</i>	3-7
3.4.5	<i>Steam Turbine Condensers</i>	3-8
3.4.6	<i>Cooling Water System</i>	3-8
3.4.7	<i>Natural Gas System</i>	3-8
3.4.8	<i>Fuel Oil System</i>	3-9
3.4.9	<i>Electrical Plant and Systems Requirements</i>	3-12
3.4.10	<i>Water Systems</i>	3-13
3.4.11	<i>Fire Protection System</i>	3-14
3.4.12	<i>Gas Pipeline Interconnection</i>	3-14
3.4.13	<i>Operations and Maintenance</i>	3-15
3.4.14	<i>Pollution Monitoring System</i>	3-15
3.5	PROJECT LIFE CYCLE OVERVIEW ALONG WITH KEY ACTIVITIES AND SCHEDULE	3-16
3.5.1	<i>Construction Activity</i>	3-16
3.5.2	<i>Operation and Maintenance</i>	3-17
3.5.3	<i>Decommissioning</i>	3-18
3.6	RESOURCES AND UTILITIES REQUIRED FOR THE PROJECT	3-18



3.6.1	<i>Land Footprint</i>	3-18
3.6.2	<i>Earth Filling</i>	3-19
3.6.3	<i>Water Footprint</i>	3-19
3.6.4	<i>Materials Storage and Handling</i>	3-24
3.6.5	<i>In-house Laboratory</i>	3-24
3.6.6	<i>Manpower Requirement</i>	3-24
3.7	SAFETY PROVISIONS	3-28
3.7.1	<i>Fire Fighting System</i>	3-28
3.7.2	<i>Grounding</i>	3-28
3.7.3	<i>Lightning Protection</i>	3-28
3.7.4	<i>Underground Gas Pipeline Protection</i>	3-28
3.7.5	<i>Health and Safety</i>	3-29
3.8	ANALYSIS OF ALTERNATIVES	3-30
3.8.1	<i>No-Project Scenario</i>	3-30
3.8.2	<i>With Project Scenario</i>	3-31
3.8.3	<i>Conclusion</i>	3-33
4	BASELINE ENVIRONMENTAL CONDITION	4-1
4.1	THE ENVIRONMENTAL BASELINE	4-1
4.1.1	<i>Project Site</i>	4-2
4.1.2	<i>Area of Influence</i>	4-2
4.2	OBJECTIVE AND METHODOLOGY	4-5
4.3	NATURAL CAPITAL: PHYSICAL ENVIRONMENT	4-5
4.3.1	<i>Landuse/cover - AOI</i>	4-5
4.3.2	<i>Topography</i>	4-9
4.3.3	<i>Geology</i>	4-13
4.3.4	<i>Soil and Sediment Quality</i>	4-17
4.3.5	<i>Hydrology and Drainage Pattern</i>	4-22
4.3.6	<i>Water Quality</i>	4-25
4.3.7	<i>Meteorology</i>	4-31
4.3.8	<i>Natural Hazards</i>	4-38
4.3.9	<i>Ambient Air Quality</i>	4-47
4.3.10	<i>Ambient Noise Levels</i>	4-54
4.3.11	<i>Traffic</i>	4-56
4.4	NATURAL CAPITAL - ECOLOGY	4-58
4.4.1	<i>Introduction</i>	4-58
4.4.2	<i>Approach and Methodology</i>	4-58
4.4.3	<i>Delineation of Area of Influence</i>	4-58
4.4.4	<i>Terrestrial Environment</i>	4-63
4.4.5	<i>Aquatic Environment</i>	4-72
4.4.6	<i>Protected Areas</i>	4-75
5	SOCIO-ECONOMIC BASELINE	5-1
5.1	INTRODUCTION	5-1
5.1.1	<i>Study Area</i>	5-1
5.1.2	<i>Methodology</i>	5-3
5.2	ADMINISTRATIVE SETTING	5-6
5.2.1	<i>Local Governance Set-up</i>	5-7
5.2.2	<i>Key Demographic Features</i>	5-7

5.2.3	<i>Industrial Profile</i>	5-8
5.3	<b>SOCIAL CAPITAL</b>	5-9
5.3.1	<i>Local Demography</i>	5-9
5.3.2	<i>Age Distribution, Sex Ratio and Literacy</i>	5-10
5.3.3	<i>Community dynamics</i>	5-10
5.3.4	<i>Prevailing Gender Dynamics</i>	5-11
5.3.5	<i>Human Rights</i>	5-11
5.4	<b>NATURAL CAPITAL</b>	5-12
5.4.1	<i>Land Tenure and Ownership Patterns</i>	5-12
5.4.2	<i>Land-based Livelihoods</i>	5-15
5.4.3	<i>Fishing Livelihoods</i>	5-19
5.5	<b>ECONOMIC CAPITAL</b>	5-22
5.5.1	<i>Occupational Profile</i>	5-22
5.5.2	<i>Informal Labour</i>	5-23
5.5.3	<i>Fixed Asset Ownership</i>	5-24
5.5.4	<i>Income</i>	5-24
5.5.5	<i>Expenditure Patterns</i>	5-26
5.5.6	<i>Indebtedness and Credit</i>	5-27
5.5.7	<i>Local Economic Markets</i>	5-27
5.6	<b>HUMAN CAPITAL</b>	5-27
5.6.1	<i>Civil Society Organisations</i>	5-27
5.6.2	<i>Skills and Formal Employment</i>	5-28
5.6.3	<i>Community Health</i>	5-28
5.7	<b>PHYSICAL CAPITAL</b>	5-29
5.7.1	<i>Social Infrastructure</i>	5-29
5.7.2	<i>Physical Infrastructure</i>	5-31
5.7.3	<i>Overview of Development Needs</i>	5-32
5.7.4	<i>Adaptation to Extreme Events</i>	5-32
5.8	<b>VULNERABILITY</b>	5-33
6	<b>IMPACT ASSESSMENT &amp; MITIGATION/ENHANCEMENT MEASURES</b>	6-1
6.1	<b>INTRODUCTION</b>	6-1
6.2	<b>ASSESSMENT METHODOLOGY</b>	6-2
6.2.1	<i>Prediction of Impacts</i>	6-2
6.2.2	<i>Characteristics of Impacts</i>	6-5
6.2.3	<i>Determining Magnitude of Impact</i>	6-7
6.2.4	<i>Sensitivity/Vulnerability/Importance of Resource/Receptor</i>	6-9
6.2.5	<i>Determining Impact Significance</i>	6-12
6.2.6	<i>Residual Impacts</i>	6-15
6.2.7	<i>Identification of Mitigation and Enhancement Measures</i>	6-15
6.3	<b>ASSESSMENT OF ENVIRONMENTAL IMPACTS - CONSTRUCTION PHASE</b>	6-16
6.3.1	<i>Soil and Sediment Quality</i>	6-16
6.3.2	<i>Water Resources</i>	6-25
6.3.3	<i>Air Quality</i>	6-31
6.3.4	<i>Noise</i>	6-36
6.3.5	<i>Ecological Impacts</i>	6-43
6.4	<b>ASSESSMENT OF ENVIRONMENTAL IMPACTS - OPERATION AND MAINTENANCE PHASE</b>	6-48
6.4.1	<i>Soil and Sediment Quality</i>	6-48
6.4.2	<i>Water Resources</i>	6-51

6.4.3	<i>Air Quality</i>	6-55
6.4.4	<i>Green House Gas Emissions</i>	6-69
6.4.5	<i>Noise</i>	6-71
6.4.6	<i>Electric and Magnetic Field (EMF)</i>	6-78
6.4.7	<i>Ecological Impacts - Operations Phase</i>	6-80
6.5	<b>ASSESSMENT OF SOCIO-ECONOMIC IMPACTS</b>	6-82
6.5.1	<i>Loss of Land</i>	6-83
6.5.2	<i>Physical Displacement</i>	6-86
6.5.3	<i>Economic Displacement</i>	6-88
6.5.4	<i>Fishing Livelihoods</i>	6-91
6.5.5	<i>Influx and In-migration</i>	6-92
6.5.6	<i>Community Health and Safety</i>	6-97
6.5.7	<i>Local Economic Benefits</i>	6-100
6.6	<b>CUMULATIVE IMPACTS DUE TO OPERATION OF BHOLA-I AND BHOLA-II OPERATIONS</b>	6-104
6.6.1	<i>Water Resources</i>	6-104
6.6.2	<i>Air Quality</i>	6-107
6.6.3	<i>Green House Gases Emissions</i>	6-118
6.6.4	<i>Noise</i>	6-119
7	<b>ENVIRONMENTAL AND SOCIAL MANAGEMENT PLAN</b>	7-1
7.1	<b>MITIGATION MEASURES</b>	7-1
7.2	<b>ENVIRONMENTAL MONITORING</b>	7-13
7.2.1	<i>Performance Indicators and Monitoring Schedule</i>	7-13
7.2.2	<i>Reporting Mechanism for Environmental and Social Monitoring Program</i>	7-13
7.3	<b>INSTITUTIONAL SETTING AND IMPLEMENTATION ARRANGEMENTS</b>	7-22
7.4	<b>TRAINING</b>	7-25
7.4.1	<i>Construction Phase</i>	7-25
7.4.2	<i>Operation Phase</i>	7-25
7.5	<b>PLANS FOR CONSTRUCTION AND OPERATION PHASE OF THE PROJECT</b>	7-26
7.5.1	<i>Construction Phase</i>	7-26
7.5.2	<i>Operation Phase</i>	7-27
7.6	<b>INSPECTION, MONITORING AND AUDIT</b>	7-29
7.7	<b>REPORTING AND DOCUMENTATION</b>	7-29
7.7.1	<i>External Reporting and Communication</i>	7-29
7.7.2	<i>Internal Reporting and Communication</i>	7-29
7.7.3	<i>Documentation</i>	7-29
7.8	<b>STAKEHOLDER ENGAGEMENT</b>	7-30
7.9	<b>ESMP REVIEW AND AMENDMENTS</b>	7-30
7.10	<b>BUDGET</b>	7-30
8	<b>STAKEHOLDER ENGAGEMENT AND PUBLIC DISCLOSURE</b>	8-1
8.1	<b>APPROACH AND METHODOLOGY FOR CONSULTATION</b>	8-1
8.2	<b>STAKEHOLDER ASSESSMENT</b>	8-1
8.3	<b>STAKEHOLDER MAPPING</b>	8-2
8.4	<b>INFORMATION DISCLOSURE AND CONSULTATION</b>	8-12
8.4.1	<i>Land Ownership Identification</i>	8-12
8.4.2	<i>Consultations during ESIA Preparation</i>	8-12
8.5	<b>KEY FEEDBACK</b>	8-13

8.6	<b>PUBLIC CONSULTATION MEETING FOR ESIA DISCLOSURE</b>	8-14
8.7	<b>WAY FORWARD</b>	8-14
9	<b>RISK ASSESSMENT</b>	9-1
9.1	<b>RA STUDY OBJECTIVE</b>	9-1
9.2	<b>RA METHODOLOGY</b>	9-2
9.3	<b>SAFETY MEASURES FOR PROPOSED FLAMMABLE STORAGEES &amp; PIPELINE</b>	9-3
9.4	<b>SAFETY MEASURES FOR CHLORINE</b>	9-3
9.5	<b>HAZARD IDENTIFICATION</b>	9-4
9.5.1	<i>Hazards from Flammable Liquid Storagees and Gas Pipelines</i>	9-5
9.5.2	<i>Hazards from Chlorine</i>	9-6
9.6	<b>FREQUENCY ANALYSIS</b>	9-8
9.6.1	<i>Frequency Analysis - Diesel Storage</i>	9-8
9.6.2	<i>Frequency Analysis - Pipeline</i>	9-10
9.6.3	<i>Frequency Analysis - Chlorine Storage Tanks</i>	9-13
9.7	<b>CONSEQUENCE ANALYSIS</b>	9-14
9.7.1	<i>Consequence Analysis - Tankages</i>	9-16
9.8	<b>RISK REDUCTION MEASURES</b>	9-36
9.8.1	<i>Design Considerations</i>	9-36
9.8.2	<i>Hazard Zone Classification</i>	9-36
9.8.3	<i>Emergency Planning &amp; Response</i>	9-36
9.8.4	<i>Safety Management Measures for Operations</i>	9-37
10	<b>CONCLUSION</b>	10-1
10.1	<b>PROJECT IMPACTS</b>	10-2
10.1.1	<i>Pre-construction Impacts</i>	10-2
10.1.2	<i>Construction Phase Impacts</i>	10-2
10.1.3	<i>Operations Phase Impacts</i>	10-3
10.2	<b>OVERALL PROJECT CATEGORISATION</b>	10-4
10.3	<b>ENVIRONMENTAL AND SOCIAL MANAGEMENT</b>	10-5
10.4	<b>RESIDUAL IMPACTS</b>	10-5
10.5	<b>CONCLUSION</b>	10-7

## LIST OF TABLES

Table 1.1	Resources/Receptors and Impacts Considered in Scoping	1-9
Table 1.2	ESIA team and their roles	1-13
Table 1.3	Layout of the Report	1-13
Table 2.1	Policies relevant to Environment	2-3
Table 2.2	National Legal Instruments relevant to the Project	2-9
Table 2.3	Project Relevant International Treaties and Conventions	2-19
Table 2.4	IFC Performance Standards	2-21
Table 2.5	Equator Principles and their Applicability for the Project	2-34
Table 2.6	Project Categorisation as per ADB Safeguards and AIIB ESS	2-40
Table 2.7	Air Emission Standards/ Guidelines	2-44
Table 2.8	Ambient Air Quality Standards/ Guidelines	2-44
Table 2.9	Effluent Standards/ Guidelines	2-45
Table 2.10	Standards for Sewage Discharge	2-46
Table 2.11	Noise Level Standards/ Guidelines	2-46
Table 2.12	Target values and soil remediation intervention values and background concentrations soil/sediment and groundwater for metals	2-47
Table 3.1	Natural Gas Specification	3-9
Table 3.2	Fuel Oil Specification	3-9
Table 3.3	Natural Gas Pipeline Specification	3-15
Table 3.4	Break-up of Land Requirement for the Project	3-18
Table 3.5	Water Requirement during the Construction Phase	3-20
Table 3.6	Raw Water Requirement during the Operation Phase	3-20
Table 3.7	Chemicals and Storage Capacity	3-24
Table 4.1	Details of Satellite Data used in the Study	4-6
Table 4.2	Land Use and Land Cover of Study Area	4-6
Table 4.3	Location of Soil and Sediment Samples	4-17
Table 4.4	Soil and Sediment Quality	4-20
Table 4.5	Standard Soil Classification	4-21
Table 4.6	Yearly minimum and maximum water surface level for the project site	4-22
Table 4.7	Details of Surface and Ground Water Sampling Locations	4-25
Table 4.8	Method for Water Analysis	4-25
Table 4.9	Surface Water Quality Analysis	4-28
Table 4.10	Groundwater quality analysis	4-30
Table 4.11	Cyclonic Storms in Bhola	4-41
Table 4.12	Landuse and Landcover of the Study Area - Year 1995, 2001 and 2016	4-45
Table 4.13	Methodology for Analysis of Ambient Air Quality	4-47
Table 4.14	Ambient Air Quality Sampling Locations	4-48
Table 4.15	Ambient Air Quality in the Study Area	4-50
Table 4.16	Details of Ambient Noise Monitoring Locations	4-54
Table 4.17	Noise Levels in the Study Area, (January - February 2013)	4-55
Table 4.18	Locations of Traffic Survey	4-56
Table 4.19	Location of Ecological Sampling Stations	4-59
Table 4.20	Abundance of Phytoplanktons and Zooplanktons	4-73
Table 5.1	Coverage of Socio-Economic Survey	5-3
Table 5.2	Number of municipality, unions, mauza, mahalla and village in Bhola District	5-7
Table 5.3	Comparative Demographic Overview of Bhola District (2011 Census)	5-8
Table 5.4	Comparative Demographic Overview of Bhola District (2001-2011)	5-8

Table 5.5	Number and types of Industries in Burhanudin Upazila	5-8
Table 5.6	Key Demographic Features of Upazilas in Bhola District -2011	5-9
Table 5.7	Demographic Features of Study Area (Unions)	5-10
Table 5.8	Age Distribution: Gender Wise	5-10
Table 5.9	Number of farm-holdings as per Land Tenure Category-Bhola District	5-12
Table 5.10	Land Ownership Pattern across surveyed villages	5-14
Table 5.11	Area under Cultivation in Study Area	5-15
Table 5.12	Rice Cropping Pattern in the Study Area	5-15
Table 5.13	Types of Fishing Nets used in the Study Area	5-20
Table 5.14	Aquaculture in Burhanuddin	5-22
Table 5.15	Daily average rate in Bhola District (in BDT)	5-24
Table 5.16	Active NGOs and their Sectoral Activities	5-27
Table 5.17	Vulnerability Assessment	5-33
Table 6.1	Activity-Impact Interaction Matrix for Construction and Operation Phases of the Project	6-3
Table 6.2	Impact Characteristic Terminology	6-5
Table 6.3	Magnitude Definitions for Physical, Biological & Human Resources/Receptors	6-8
Table 6.4	Definitions of Sensitivity/Importance /Vulnerability Biophysical and Human	6-10
Table 6.5	Habitat-Impact Assessment Criteria	6-10
Table 6.6	Species-Impact Assessment Criteria	6-11
Table 6.7	Sensitivity Assessment Criteria for Soil and Sediment quality (compaction, erosion and contamination) and Landuse	6-17
Table 6.8	Criteria for Impact Magnitude for Assessment of Impact to Soil and Sediment Quality and Landuse	6-18
Table 6.9:	Sensitivity Assessment Criteria for Water Resources (Surface water and Ground water)	6-26
Table 6.10	Criteria for Impact Magnitude for Assessment of Impact to Surface and Ground water Resources	6-27
Table 6.11	Sensitivity Criteria for Air quality	6-32
Table 6.12	Criteria for Impact Magnitude for Assessment of Impact to Air Quality (Construction Phase)	6-33
Table 6.13	Assumed Construction Equipment Sound Pressure Level Inventory	6-37
Table 6.14	Sensitivity Assessment Criteria for Ambient Noise Impacts	6-37
Table 6.15	Magnitude Assessment Criteria for Ambient Noise Impacts	6-38
Table 6.16	Predicted Noise Levels at Noise Receptors during Construction Phase	6-41
Table 6.17	Impact due to Habitat Loss	6-44
Table 6.18	Impact due to Habitat Disturbance	6-47
Table 6.19	Modelling Scenarios for Air Quality Impact Assessment	6-55
Table 6.20	Emission Parameters for the Power Plant with Natural Gas as Fuel	6-57
Table 6.21	Emission Parameters for the Power Plant with HSD as Fuel	6-57
Table 6.22	Criteria for Impact Magnitude for Assessment of Impact to Air Quality (Operation Phase)	6-58
Table 6.23	Monitoring Locations with respect to the Project	6-60
Table 6.24	Predicted Concentrations at Receptors due to Operation of NBBL with Gas and HSD as Fuel	6-63
Table 6.25	Estimated GHG Emissions from the Plant	6-70
Table 6.26	Noise Emission Criteria	6-73
Table 6.27	Predicted Noise Levels at Noise Receptors during Operation Phase of NBBL Project	6-76
Table 6.28	Impact due to Habitat Disturbance	6-81

Table 6.29	Land Owner Distribution as per Union	6-84
Table 6.30	Summary of Emissions for the Power Plants for Separate stacks within Power Generation Complex	6-108
Table 6.31	Predicted Concentrations at Receptors due to Operation of Bhola-I and Bhola-II Projects - with Gas and HSD as Fuel	6-110
Table 6.32	Estimated GHG Emissions from the Bhola-I and II Project	6-118
Table 6.33	Predicted Noise Levels at Noise Receptors during Operation Phase of Bhola-I and Bhola-II Projects	6-122
Table 7.1	Environmental and Ecological Management Plan of the Project	7-3
Table 7.2	Social Management and Monitoring Plan	7-11
Table 7.3	Environmental Monitoring Programme (Construction and Operation Phase)	7-15
Table 7.4	Roles and Responsibilities of Project Developer and EPC Contractor	7-22
Table 8.1	Stakeholder Profile and Mapping	8-1
Table 9.1	Effects of Chlorine at Various Concentrations	9-7
Table 9.2	Frequency Categories and Criteria	9-8
Table 9.3	Tank Failure Frequency	9-8
Table 9.4	Primary Gas Pipeline Failure Frequency	9-10
Table 9.5	Primary Failure Frequency based on Diameter Class (1970-2013)	9-11
Table 9.6	Natural Gas Pipeline - Failure Frequency	9-12
Table 9.7	Natural Gas Pipeline -Jet Fire Probability	9-13
Table 9.8	Chlorine Storage - Failure Rates based on Type of Release	9-14
Table 9.9	Severity Categories and Criteria	9-14
Table 9.10	Risk Matrix	9-15
Table 9.11	Risk Criteria and Action Requirements	9-15
Table 9.12	Diesel Storage Tank - Risk Modelling Scenarios	9-16
Table 9.13	Pipeline Risk Modelling Scenarios	9-24
Table 9.14	Chlorine Tonner - Risk Modelling Scenarios	9-30
Table 10.1	Summary of Impact Assessment and Residual Impacts	10-5

## LIST OF FIGURES

Figure 0.1	Project Location	ii
Figure 0.2	Key Project Components	iii
Figure 0.3	Raw Material, Land and Natural Resource Footprint	iv
Figure 0.4	Methodology for the Socio-economic Baseline	ix
Figure 0.5	Summary of the Socio-economic Baseline	x
Figure 0.6	Summary of the Environmental Profile	xi
Figure 0.7	Summary of Soil and Water Quality	xii
Figure 0.8	Summary of Air and Noise Quality	xiii
Figure 0.9	Summary of Ecological Profile	xiv
Figure 0.10	Impact Assessment Process	xv
Figure 0.11	Existing Bhola I Premises	xviii
Figure 0.12	Biodiversity Features	xix
Figure 0.13	Artisanal Fishing Activities	xx
Figure 0.14	Overview of E&S Impacts	xxii
Figure 0.15	Public Consultation Meeting, 6 March 2017	xxvi
Figure 1.1	Location of the Project Site	1-5
Figure 1.2	Impact Assessment Process	1-9
Figure 1.3	Sustainable Livelihoods Framework	1-11
Figure 1.4	Impact Assessment Approach	1-12
Figure 2.1	DOE Environmental Clearance Applicability and Procedure	2-16
Figure 2.2	Flow Chart of EIA Process Applicable to the Proposed Project	2-17
Figure 3.1	Aerial View of the Project Site in NBBL Power Generation Complex	3-3
Figure 3.2	Layout Plan of proposed Project	3-4
Figure 3.3	Key Features in the Surroundings	3-6
Figure 3.4	Fuel Oil Pump House at Tank Farm Area	3-10
Figure 3.5	Fuel Oil Storage Tank Layout	3-11
Figure 3.6	Water Balance	3-21
Figure 3.7	Industrial Wastewater Treatment System Flow Diagram	3-22
Figure 3.8	Schematic Diagram of Sewage Treatment Plant	3-23
Figure 3.9	Proposed Organisation Structure of NBBL during Project Construction	3-26
Figure 3.10	Proposed Operation and Maintenance Organization Chart	3-27
Figure 3.11	Environment, Occupational Health & Safety and Quality Management System Certification of the EPC Contractor	3-30
Figure 4.1	Resources and Receptors as per Sustainable Livelihoods Framework	4-2
Figure 4.2	AOI at 10 Km from the Project Site with Receptors Locations	4-4
Figure 4.3	Landuse/ Landcover Map of the Project AOI	4-8
Figure 4.4	Digital Elevation Map of the 10km Study Area	4-10
Figure 4.5	Slope Map of Project AOI	4-11
Figure 4.6	Topography of Project Site and immediate surrounding	4-12
Figure 4.7	Bhola Island: Part of an Active Delta	4-15
Figure 4.8	Geological Map of Bangladesh	4-16
Figure 4.9	Soil, Sediment and Water Sampling Locations	4-19
Figure 4.10	Drainage Map of Project AOI	4-24
Figure 4.11	Climatic Sub-regions of Bangladesh	4-32
Figure 4.12	Normal Maximum and Minimum Temperature Profile in Bhola	4-33
Figure 4.13	Normals of Relative Humidity in Bhola	4-33
Figure 4.14	Normals of Rainfall in Bhola	4-34



Figure 4.15	Monthly Windrose Diagrams of Project Site	4-36
Figure 4.16	Annual Wind Rose and Wind Class Frequency Distribution	4-37
Figure 4.17	Earthquake Zone Map of Bangladesh	4-39
Figure 4.18	Seismicity Map of Bangladesh and Neighbouring Areas	4-40
Figure 4.19	Cyclonic Storm Tracks in Bangladesh	4-42
Figure 4.20	Cyclone map of Bangladesh	4-43
Figure 4.21	Flood Map of Bangladesh	4-44
Figure 4.22	Landuse and Landcover - 1995, 2001 and 2016	4-46
Figure 4.23	Air Quality, Noise and Traffic Monitoring Locations Map	4-49
Figure 4.24	SPM Concentration Pattern in the Project AOI	4-51
Figure 4.25	PM <sub>10</sub> Concentration Pattern in the Project AOI	4-51
Figure 4.26	PM <sub>2.5</sub> Concentration Pattern in the Project AOI	4-52
Figure 4.27	SO <sub>2</sub> Concentration Pattern in the Project AOI	4-52
Figure 4.28	NO <sub>x</sub> Concentration Pattern in the Project AOI	4-53
Figure 4.29	CO Concentration Pattern in the Project AOI	4-53
Figure 4.30	Noise Levels Recorded in the Study Area	4-55
Figure 4.31	Traffic Volume in the access road connecting the Project site	4-57
Figure 4.32	River Traffic in Dehular Canal	4-57
Figure 4.33	Description of Sample Plot	4-59
Figure 4.34	Map showing location of Sampling Stations	4-62
Figure 4.35	Bio-ecological Zones of Bangladesh	4-64
Figure 4.36	Photo representation in Core Zone	4-65
Figure 4.37	Major Habitat types Sampled in the Buffer Zone	4-66
Figure 4.38	Herpetofaunal Species in the AoI	4-69
Figure 4.39	Avifaunal Species in the AoI	4-70
Figure 4.40	Mammal Species in AoI	4-72
Figure 4.41	Planktonic Sampling in AoI	4-73
Figure 4.42	Fish Species in AoI based on Fish Market Survey	4-74
Figure 4.43	Ganges-Brahmaputra-Meghna delta in Bangladesh IBA (A1, A4i, A4iii)	4-76
Figure 5.1	Study Area	5-2
Figure 5.2	Household Survey and FGD locations	5-5
Figure 5.3	Administrative Profile of Bangladesh	5-6
Figure 5.4	Saw mill and Furniture Shop in Burhanuddin Town	5-9
Figure 5.5	Land Ownership Pattern in Surveyed Villages	5-14
Figure 5.6	Agriculture in Study Area	5-16
Figure 5.7	Rendhi Timber Trade	5-18
Figure 5.8	Households owning different cattle	5-18
Figure 5.9	Types of Fishing Boats	5-20
Figure 5.10	Occupational Profile in the Study Area	5-23
Figure 5.11	Average Monthly Income from various sources in Study Area	5-25
Figure 5.12	Households in different income groups (monthly income in BDT)	5-25
Figure 5.13	Households living above and below poverty line	5-26
Figure 5.14	Expenditure Pattern	5-26
Figure 5.15	Infrastructure Profile of Burhanuddin Upazilla	5-29
Figure 5.16	Gender wise - level of formal education (in %)	5-30
Figure 5.17	Cyclone shelter in Shantipara Village, Kachia	5-33
Figure 6.1	Impact Assessment Process	6-2
Figure 6.2	Impact Significance	6-13
Figure 6.3	Predicted Construction Noise Levels during Daytime (Leq <sub>day</sub> )	6-39
Figure 6.4	Predicted Construction Noise Levels during Night time (Leq <sub>day</sub> )	6-40

Figure 6.5	Traffic at Dehular Khal and Dredging Activities in Tentulia river	6-46
Figure 6.6	Fishing Activities from Dehular Khal	6-46
Figure 6.7	Receptor Network and Emission Sources	6-62
Figure 6.8	NOx Isopleths - 1 Hourly Maximum Ground Level Concentrations (NBBL Operation with Natural Gas as Fuel)	6-64
Figure 6.9	NOx Isopleths - 1 Hourly Maximum Ground Level Concentrations (NBBL Operation with HSD as Fuel)	6-64
Figure 6.10	NOx Isopleths - 24 Hourly Maximum Ground Level Concentrations (NBBL Operation with Natural Gas as Fuel)	6-65
Figure 6.11	NOx Isopleths - 24 Hourly Maximum Ground Level Concentrations (NBBL Operation with HSD as Fuel)	6-65
Figure 6.12	NOx Isopleths - Annual Average Ground Level Concentrations (NBBL Operation with Natural Gas as Fuel)	6-66
Figure 6.13	NOx Isopleths - Annual Average Ground Level Concentrations (NBBL Operation with HSD as Fuel)	6-66
Figure 6.14	SO <sub>2</sub> Isopleths - 24 Hourly Maximum Ground Level Concentrations (NBBL Operation with HSD as Fuel)	6-67
Figure 6.15	SO <sub>2</sub> Isopleths - Annual Average Ground Level Concentrations (NBBL Operation with HSD as Fuel)	6-67
Figure 6.16	PM <sub>10</sub> Isopleths - 24 hourly Maximum Ground Level Concentrations (NBBL Operation with HSD as Fuel)	6-68
Figure 6.17	PM <sub>10</sub> Isopleths - Annual Average Ground Level Concentrations (NBBL Operation with HSD as Fuel)	6-68
Figure 6.18	Noise Sources and Receptors Location in Topographic Map	6-74
Figure 6.19	Predicted Operation Phase Noise Levels of NBBL Project during Daytime (Leq <sub>day</sub> )	6-75
Figure 6.20	Type of Structures Impacted	6-87
Figure 6.21	Treated Wastewater Discharge Locations of Bhola-I and Bhola-II Projects	6-106
Figure 6.22	NOx Isopleths - 1 Hourly Maximum Ground Level Concentrations (NBBL and BPDB Operations with Natural Gas as Fuel)	6-113
Figure 6.23	NOx Isopleths - 1 Hourly Maximum Ground Level Concentrations (NBBL Operation with HSD as Fuel and BPDB Operation with Natural Gas as Fuel)	6-113
Figure 6.24	NOx Isopleths - 24 Hourly Maximum Ground Level Concentrations (NBBL and BPDB Operations with Natural Gas as Fuel)	6-114
Figure 6.25	NOx Isopleths - 24 Hourly Maximum Ground Level Concentrations (NBBL Operation with HSD as Fuel and BPDB Operation with Natural Gas as Fuel)	6-114
Figure 6.26	NOx Isopleths - Annual Average Ground Level Concentrations (NBBL and BPDB Operations with Natural Gas as Fuel)	6-115
Figure 6.27	NOx Isopleths - Annual Average Ground Level Concentrations (NBBL Operation with HSD as Fuel and BPDB Operation with Natural Gas as Fuel)	6-115
Figure 6.28	SO <sub>2</sub> Isopleths - 24 Hourly Maximum Ground Level Concentrations (NBBL Operation with HSD as Fuel and BPDB Operation with Natural Gas as Fuel)	6-116
Figure 6.29	SO <sub>2</sub> Isopleths - Annual Average Ground Level Concentrations (NBBL Operation with HSD as Fuel and BPDB Operation with Natural Gas as Fuel)	6-116
Figure 6.30	PM <sub>10</sub> Isopleths - 24 hourly Maximum Ground Level Concentrations (NBBL Operation with HSD as Fuel and BPDB Operation with Natural Gas as Fuel)	6-117
Figure 6.31	PM <sub>10</sub> Isopleths - Annual Average Ground Level Concentrations (NBBL Operation with HSD as Fuel and BPDB Operation with Natural Gas as Fuel)	6-117
Figure 6.32	Predicted Operation Phase Noise Levels of Bhola-I and Bhola-II Projects during Night-time (Leq <sub>night</sub> )	6-121

Figure 7.1	Organization Chart for Environmental and Social Management and Reporting Responsibilities during Construction and Operation Phase of the Project	7-24
Figure 7.2	Emergency Response Action Tree	7-28
Figure 9.1	Risk Assessment Methodology	9-2
Figure 9.2	Event Tree Analysis - Tank Failure	9-9
Figure 9.3	Gas Pipeline Failure - Distribution of Incident & Causes	9-11
Figure 9.4	Threat Zone Plot -5% Mass Release & Ignition of Diesel Tank	9-17
Figure 9.5	Threat Zone Plot -15% Mass Release & Ignition of Diesel Tank	9-19
Figure 9.6	Threat Zone Plot -50% Mass Release & Ignition of Diesel Tank	9-20
Figure 9.7	Natural Gas Release - Potential Consequences	9-22
Figure 9.8	Threat Zone Plot - Natural Gas Pipeline Leak (25mm dia)	9-25
Figure 9.9	Threat Zone Plot - Natural Gas Pipeline Leak (50mm dia)	9-27
Figure 9.10	Threat Zone Plot - Natural Gas Pipeline Rupture	9-28
Figure 9.11	Threat Zone Plot- Chlorine Tonner Leak (5mm dia)	9-31
Figure 9.12	Threat Zone Plot- Chlorine Tonner Leak (105mm dia)	9-33
Figure 9.13	Threat Zone Plot-Catastrophic Failure of Chlorine Tonner	9-34

## *LIST OF ANNEX*

Annex A	Letter of Intent
Annex B	Certificate of Incorporation
Annex C	Approved ToR by DoE (3.11.2016)
Annex D	NoC UNO Thana Parishad
Annex E	Upazilla NoC
Annex F	Screening against ADB SPS Checklists
Annex G	Design basis of Water Treatment Plant
Annex H	DM Plant Design Basis Report
Annex I	Design basis of Effluent Treatment Plant
Annex J	Design basis of Sewage Treatment Plant
Annex K	Detailed Implementation Schedule
Annex L	EPC Contractor Profile
Annex M	Faunal Species
Annex N	Amphibian Species
Annex O	Reptile Species
Annex P	Avifauna Species
Annex Q	Mammal Species
Annex R	Fish Species
Annex S	Critical Habitats Assessment
Annex T	List of Land Owners
Annex U	Stakeholder Consultation Minutes
Annex V	Baseline Monitoring Reports
Annex W	Public Consultation Minutes
Annex X	Social Framework Management Plans

## **ABBREVIATIONS**

ACC	Air-Cooled Condenser
ADB	Asian Development Bank
AERMOD	AMS/EPA Regulatory Model
AGI	Above Ground Installation
AH	Animal Husbandry
AIIB	Asian Infrastructure Investment Bank
AIS	Air Insulated Sub-station
AL	Agricultural Labourer
ALARP	As Low As Reasonably Practicable
AoA	Analysis of Alternatives
AoI	Area of influence
AP	Action Plan
ARIPO	Acquisition and Requisition of Immovable Property Ordinance
ASA	Association for Social Advancement (Organisation that provides micro-credit)
ASME	Society of Mechanical Engineers
ASR	Area Sensitivity Rating
ASTM	American Society for Testing and Materials
ASTER	Advanced Spaceborne Thermal Emission and Reflection Radiometer
AQ	Air Quality
AZE	Alliance for Zero Extinction
BDT	Bangladesh Taka
BFIDC	Bangladesh Forest Industries Development Corporation
BFRI	Bangladesh Forest Research Institute
BMD	Bangladesh Meteorological Department
BNH	Bangladesh National Herbarium
BOD	Biological Oxygen Demand
BOO	Build, Own, and Operate
BOOT	Build, Own, Operate, and Transfer
BPC	Bangladesh Petroleum Corporation
BPDB	Bangladesh Power development Board
BRAC	Building Resources Across Communities (Organisation)
BTG	Boiler Turbine Generator
CCPP	Combined Cycle Power Plants
CEET	Carbon Emission Estimation Tool
CEMS	Continuous Emission Monitoring System
C & I	Control & Instrumentation
CLAC	Central Land Allocation Committee
CL-O	Cultivator as Owner
CL-T	Cultivator as Tenant
CO <sub>2</sub>	Carbon dioxide
COD	Chemical Oxygen Demand
COO	Chief Compliance Officer
CR	Critically Endangered
CRE	Control Room Engineer

CSR	Corporate Social Responsibility
CTG	Combustion turbine and generator
CW	Contractual Labourer
CW	Circulating Water
DC	Deputy Commissioner
DD	Data Deficient
DEM	Digital Elevation Model
DFID	Department for International Development
DG	Diesel Generator
DLACs	District Land Allocation Committees
DM	Demineralization
DM	District Magistrate
DO	Dissolved Oxygen
DoE	Department of Environment
ECA	Ecologically Critical Areas
ECC	Environmental Clearance Certificate
ECR	Environment Conservation Rules
EGIG	European Gas Pipeline Incident Data Group
EHS	Environment, Health and Safety
EIA	Environmental Impact Assessment
EMF	Electromagnetic Field
EMP	Environmental Management Plan
EN	Endangered
EP	Equator Principles
EPC	Engineering, Procurement, and Construction
ERM	Environmental Resources Management
ERP	Emergency Response Plan
ERT	Emergency Response Team
ESMP	Environmental and Social Management Plan
ESMS	Environmental and Social Management System
ESS	Environmental and Social Standards
ETP	Effluent Treatment Plant
F & A	Finance and Accounting
FE	Field Engineer
FD	Forest Department
FGD	Focused Group Discussions
FI	Financial Intermediary
FPIC	Free, Prior and Informed Consent
FSA	Fuel Supply Agreement
GAP	Gender Action Plan
GE	General Electric
GHG	Green-house gas
GIIP	Good International Industry Practices
GIS	Gas Insulated Substations
GIS	Gas Insulated Substations
GLC	Ground Level Concentrations
GoB	Government of Bangladesh
GRM	Grievance Redress Mechanism
GSA	Gas Supply Agreement
GT	Gas Turbine

GWP	Global Warming Potential
HFL	High Flood Level
HO	Head Office
HPCL	Hindustan Petroleum Corporation Limited
HR	Human Resources
HRSG	Heat Recovery Steam Generator
HSD	High Speed Diesel
HYV	High Yielding Variety
FO	Fuel Oil
IA	Implementation Agency
IBA	Important Bird Area
I & C	Instrumentation and Control
ICP	Informed Consultation and Participation
IEC 60079	International Electrotechnical Commission
IECs	Important Environmental Components
IEE	Independent Environmental Examination
IS - IEEE	International Standard - The Institute of Electrical and Electronics Engineers
IFC	International Finance Corporation
ILO	International Labour Organisation
IP	Indigenous People
IPP	Independent Power Plant
IPPF	Indigenous People Planning Framework
IR	Involuntary Resettlement
ISO	International Organisation for Standardisation
IUCN	International Union for Conservation of Nature
JV	Joint Venture
Leq	Equivalent Continuous Level to describe sound
LGED	Local Government Engineering Department
LIMP	Labour and Influx Management Plan
LLA	Land Lease Agreement
LNG	Liquified Natural Gas
LOC	Level of Concern
LOI	Letter of Intent
LPG	Liquid Petroleum Gas
LTM	Local Traffic Movement
MIS	Management Information System
MoEF	Ministry of Environment & Forest
NAAQS	National Ambient Air Quality Standards
NAL	Non-agricultural labourer
NBBL	Nutan Bidyut Bangladesh Limited
NEC	National Electrical Code
NEMAP	National Environmental Management Action Plan
NFPA	National Fire Prevention Association
NGHSDO	Natural Gas and High Speed Diesel Oil
NGO	Non-Governmental Organisation
NHAI	National Highway Authorities of India
NOC	No-objection certificate
NOx	Oxides of Nitrogen
NT	Near Threatened

O&M	Operations and Maintenance
OEM	Original Equipment Manufacturer
OGP	Oil & Gas Producers
OHSAS	Occupational Health and Safety Assessment System
OISD	Oil Industry Safety Directorate
PA	Project Agreement
PD	Power Division
PGCB	Power Grid Company of Bangladesh
PM	Particulate Matter
PP	Project Proponent
PPA	Power Purchase agreement
PPE	Personal Protective Equipment
PS	Performance Standards
RA	Risk Assessment
RA	Rural Artisan
REA	Rapid Environmental Assessment
RET	Rare, Endangered and Threatened
RF	Resettlement Framework
RMS	Regulating and Metering Station
RoW	Right of Way
RP	Resettlement Plan
SCE	Shift Charge Engineer
SG	Service in Government Sector
SGCL	Sundarban Gas Company Ltd
SIA	Social Impact Assessment
SMS	Social Management Systems
SO <sub>2</sub>	Sulphur dioxides
SP	Service in Private Sector
SP INFRA	Sahpoorji Pallonji Infrastrucutre Capital Company Pvt Ltd
SPA	Share Purchase Agreement
SPL	Sound Power Level
SPS	Safeguard Policy Statement
SPV	Special Purpose Vehicle
SR	Safeguards Requirements
SRTM	Shuttle Radar Topography Misison
ST	Steam turbine
ST	Small Trader
STP	Sewage Treatment Plant
ToR	Terms of Reference
TPP	Thermal Power Plant
UFW	Unpaid Family Work
UGI	Under ground installation
UM	Unemployed Seeking employment
UNFCCC	United Nations Framework Convention on climate change
UNO	Union Nirbhani Officer
USA	United States of America
UTM	Universal Transverse Mercator
VCE	Vapour Cloud Explosion
VOC	Volatile Organic Chemicals
VU	Vulnerable



WHO World Health Organisation

WTP Water Treatment Plant

Units	Description
µg	Micro gram
AC	Alternating current
amsl	Above mean sea level
BOD	Biochemical Oxygen Demand
COD	Chemical Oxygen Demand
dB	Decibel
dia	Diameter
ft	Feet
hr	Hour
Ha	Hectare
Kg	Kilogram
KJ	Kilo joules
km	Kilo metre
km <sup>2</sup>	Square kilo metre
kV	Kilo volt
KWh	Kilo watt hour
lt	Litre
m <sup>3</sup>	Cubic metre
mg	Mili gram
Mm	Millimetre
MVA	Mega volt ampere
MW	Mega Watt
NH <sub>4</sub>	Ammonium
nm	Nano metre
pH	Potential of Hydrogen
PM	Particulate Matter
ppm	parts per million
psi	per square inch
Sq. m.	Square meter
tCO <sub>2</sub> e	Tonnes of equivalent carbon dioxide
TDS	Total Dissolved Solids
Tk	Taka (Bangladeshi Currency)

## 0.1 INTRODUCTION AND BACKGROUND

The Government of Bangladesh (GoB) has adopted a strategy for the development of the power sector which envisages private participation. In line with this strategy, the GoB has decided to implement a new Greenfield 225 MW Combined Cycle Power Plant (CCPP) on Build, Own and Operate (“BOO”) basis under the Independent Power Producer (IPP) program in Bhola District, Bangladesh.

Nutan Bidyut (Bangladesh) Limited (hereinafter referred to as NBBL) was issued a Letter of Intent (LOI) for the development of the project from the Bangladesh Power Development Board (BPDB) on 18<sup>th</sup> April 2016. The Project (referred as Bhola II) is located on Bhola Island beside BPDB’s existing power plant (Bhola I CCPP), at Kutuba Union, Burhanuddin Upazilla, Bhola District. The Plant is proposed to be operated on Natural Gas as primary fuel and High Speed Diesel (HSD) as a backup fuel in case of interruption on natural gas supply to the plant. The electricity generated will be sold under a 22 year Power Purchase Agreement (PPA) with BPDB.

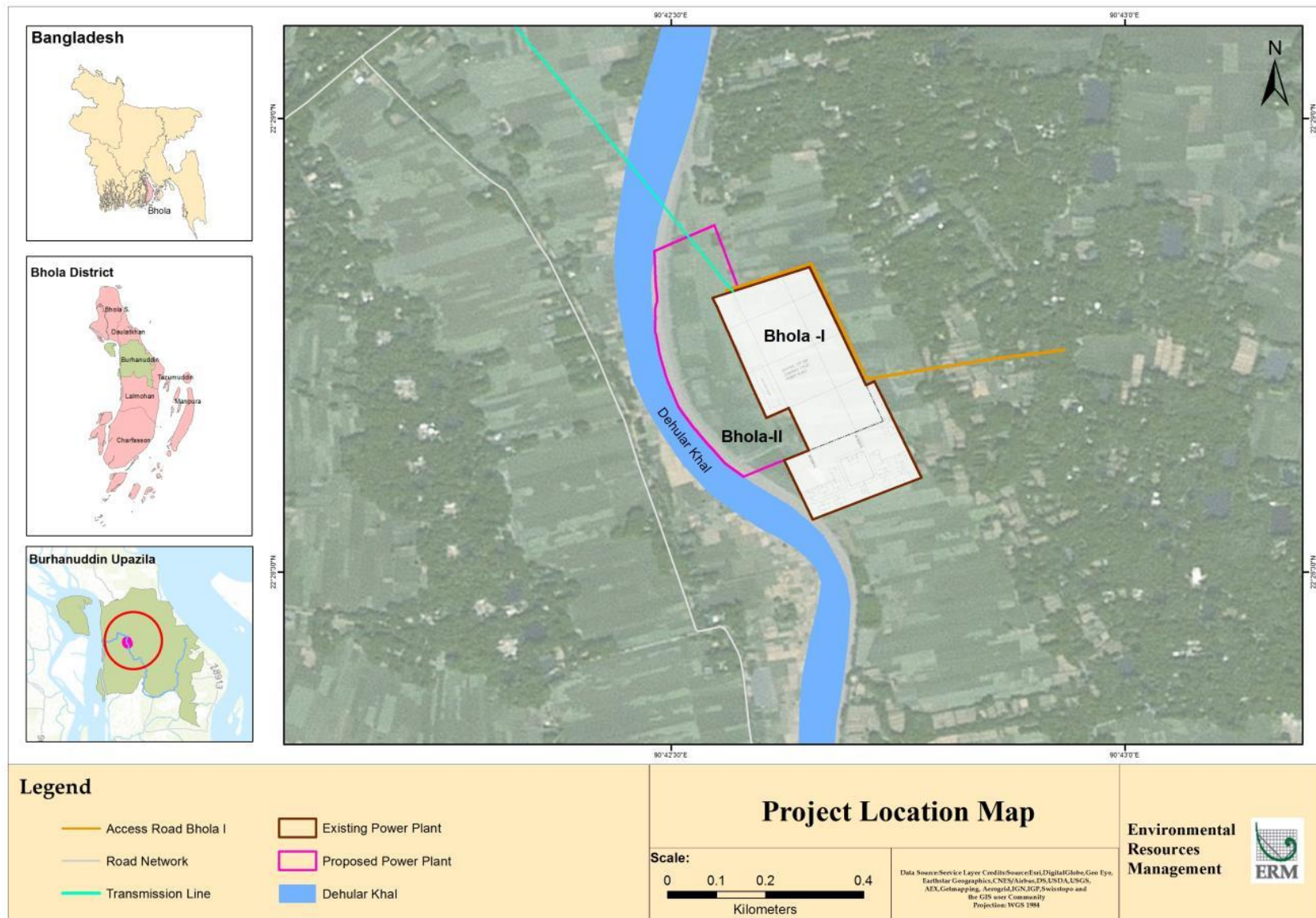
**Box 0.1** *About the Project Proponent*

The project proponent, i.e. Nutan Bidyut (Bangladesh) Limited, is a subsidiary of M/s Shapoorji Pallonji Infrastructure Capital Company Pvt. Ltd (SP Infra) which has been formed and registered under the Laws of the People’s Republic of Bangladesh to develop, design, finance, build, own, operate and maintain the plant. Shapoorji Pallonji Infrastructure Capital Company Ltd. (SP Infra), a subsidiary of Shapoorji Pallonji Group was formed with the vision of developing infrastructure assets. SP Infra has built on the group's strength in contracting, construction and financing of projects, and in near future aspires to become the major player in infrastructure development and operations in its chosen areas of business, i.e. energy, ports and transportation. The SP Group promotes sustainable development through four focus areas: (a) improve the quality of life; (b) promote inclusion and development; (c) provide education and skills training; and (d) preserve the environment.

This non-technical summary (NTS) presents salient features of the project, the main findings and the conclusions of the Environmental and Social Impact Assessment (ESIA). The ESIA has been prepared in accordance with the following:

- Approval of Terms of Reference (ToR) for the Environmental Impact Assessment (EIA) dated 3<sup>rd</sup> November 2016 from the Department of Environment (DoE);
- Applicable Bangladesh national, regional and local regulations;
- International conventions and agreements ratified by Bangladesh;
- ADB’s Safeguard Policy Statement (SPS) (2009) and specific requirements;
- IFC Performance Standards for Environmental and Social Sustainability (2012);
- IFC General EHS Guidelines (2007) and for Thermal Power Plants (2008);
- Equator Principles III (2013); and
- The Asian Infrastructure Investment Bank (AIIB) Environmental and Social Framework (2016).

Figure 0.1 **Project Location**



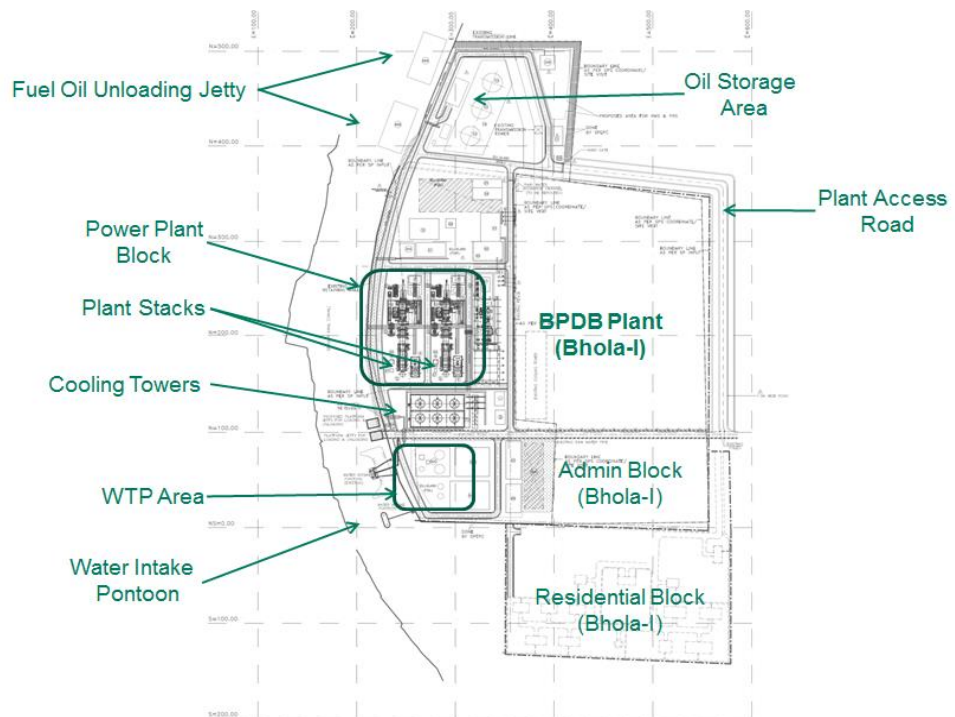
### Project Components

The main power block of the Plant will consist of two dual fuel gas turbine (“GT”), one steam turbine (“ST”), two heat recovery steam generators (“HRSG”) and bypass and main stacks. Emergency diesel generators will be provided to ensure safe shutdown. The key components (illustrated in the subsequent figure) include:

- Gas Turbine - 2 no.
- Heat Recovery Steam Generator - 2 no.
- Steam Turbine - 1 no.
- Condenser;
- Fuel Gas Transportation, Compression and Conditioning System;
- HSD Transportation and Storage;
- Water System including river water cooling system;
- Electrical System;
- Air Conditioning and Ventilation System;
- Control and Instrumentation System;
- Water intake pontoon and fuel unloading jetty;
- Civil Works.

Figure 0.2

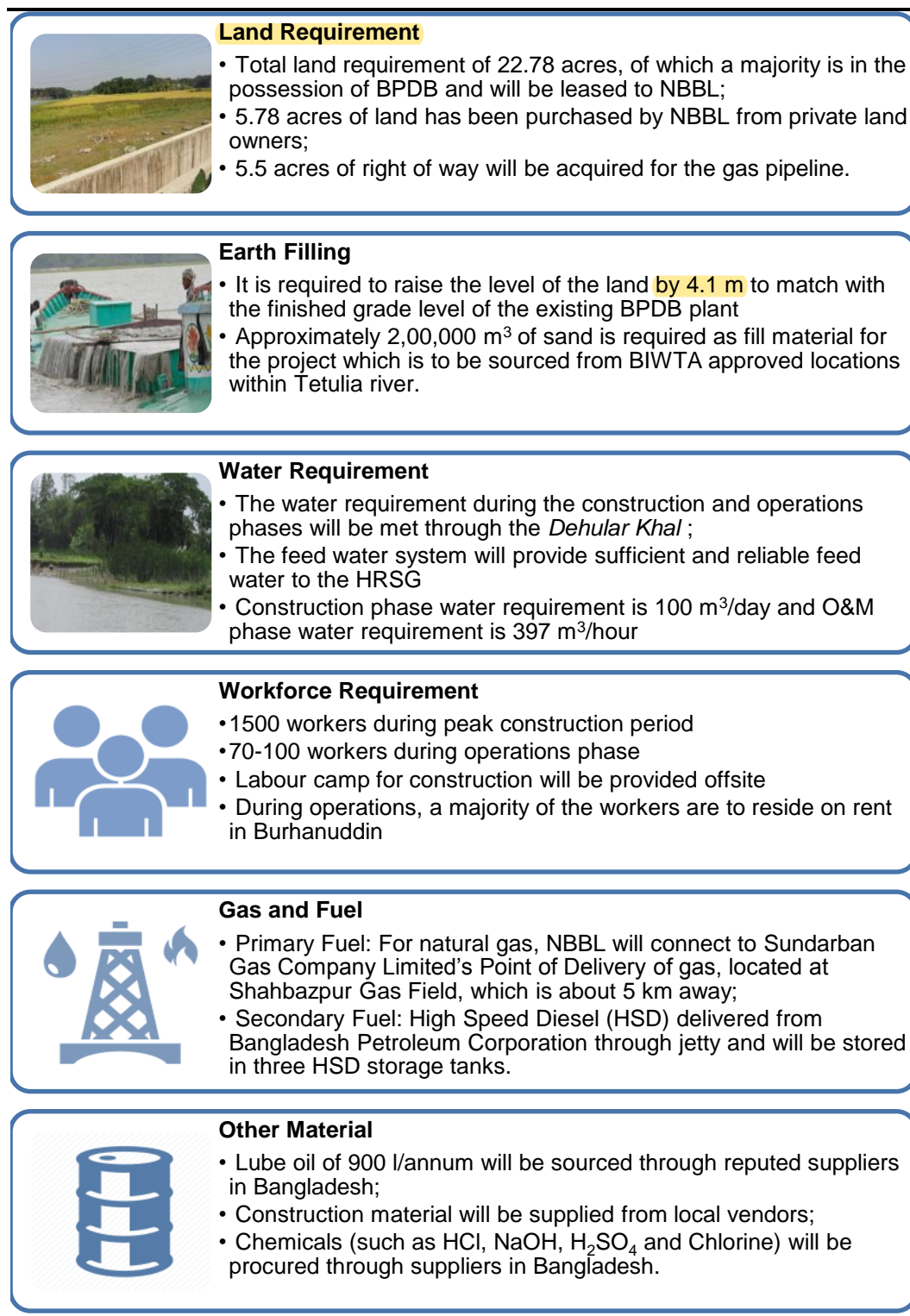
### Key Project Components



Power would be available at 230 kV level in the Existing 230 kV outdoor switchyard and would be fed to PGCB grid through existing transmission lines to Barisal sub-station.

The following figure illustrates the overall raw material, land and natural resources footprint:

Figure 0.3 Raw Material, Land and Natural Resource Footprint



Treated effluent and cooled water will be discharged into Dehular canal through a 350 pipeline from the guard pond. A separate storm water drain channel will also be constructed to join Bhola I discharge channel near the outfall location. The project will also include fire protection systems and pollution monitoring systems.



## *Project Lifecycle and Timelines*

Early works prior to commencement of construction will include:

- construction of approach road, boundary wall, some of the in-plant roads, identifying space for construction offices of the sub-contractors of vendors, temporary fire-fighting system, construction water and construction power facility;
- This would be followed by filling and earthworks, site levelling and grading, construction of in-plant road network for ease of movement of plant and equipment and developing temporary drainage facility; labour camp for construction etc.

All the mechanical, electrical, civil and I&C construction materials along with consumables will be procured by the contractors of individual package. Cement and reinforcement materials will be sourced from Dhaka, sand and gravels will be sourced from Sylhet and sand is available nearby

Since the infrastructure for maintenance of the specialized plant and machinery may not be readily available near the site, adequate maintenance facilities for day-to-day and minor plant maintenance including a well-equipped workshop and trained technicians would be developed for the project.

The project is expected to achieve Financial Closure by end of Q1 in FY 2018. After the same, construction is expected for approximately 2-2.5 years up to March 2020. The design life of the power plant is estimated to be 30 years, which is almost 8 years more than the Power Purchase Agreement term. If the Power Purchase Agreement, Land Lease Agreement, Gas Supply Agreement and the other relevant agreements are not extended or renewed and an alternative economical fuel is available, the power plant may be retrofitted to support alternative power generation.

## **0.2**

### ***PROJECT ALTERNATIVES***

The ESIA has reviewed the process by which specific considerations into the location, design and extent of adverse impacts were assessed and the alternatives that have been considered during the development and pre-feasibility process.

#### *No Project*

Actual electricity demand in the country has not been met due to a shortage of available generation capacity. In addition, due to a shortage of gas supply, some power plants are unable to reach their full generation capability. The current supply-demand in Bangladesh also has a knock on effect on all other key sectors including agriculture, industry, commercial and domestic sectors. There is therefore no alternative to adding more power generating units to the existing power system of Bangladesh, to help improve and meet the energy demand for both domestic and industrial requirements.

The 'No Project Scenario' is also likely to have a negative effect on opportunities for employment, both directly from the proposed power project and its dependant sectors such as agriculture, industries and manufacturing that require stable power supply in order to operate and be competitive.

#### *Site Location*

The proposed site including Bhola I project site was acquired by BPDB in early 2000 to develop a power generation complex in order to utilise the natural gas available from the Shahbazpur Gas Field. BPDB has already constructed one 225 MW CCPP (Bhola I) at this complex. The site location is well suited for setting up of power plant with availability of adequate availability of land, water, access to road, and waterways, fuel source/supply arrangement. Associated facilities, such as, water intake and abstraction mechanism, pump house location, construction laydown and camp areas have also been selected based on the basis of alternative analysis and selection of best suited option.

#### *Design*

The project design has considered embedded pollution control systems, which include NOx control, stack height for dispersion of pollutants, use of cleaner primary fuel (natural gas), use of Dehular Canal water for the Project as opposed to ground water, induced draft cooling tower for reducing water requirement and no direct discharge of cooling water into Dehular Khal. Best suited technological options have been considered by NBBL and the dual fuel system has been selected to provide more reliability of power generation.

### **Box 0.2**

#### ***Key Environmental and Social Considerations***

Location	Land Footprint	Water Requirement
<ul style="list-style-type: none"> <li>• No major sensitive environmental receptors such as protected forests and wetlands in close proximity;</li> <li>• No physical cultural resources on site and in close proximity</li> <li>• No eco-sensitive area in close proximity</li> </ul>	<ul style="list-style-type: none"> <li>• Land requirement has been minimized by using the existing BPDB site and right of way for the pipeline entails minimum expansion;</li> <li>• Avoidance of physical displacement to the extent feasible</li> </ul>	<ul style="list-style-type: none"> <li>• Consideration of induced cooling system which entails additional cost;</li> <li>• This entails reduced water requirement and also minimizes warm water discharge into the Dehular canal</li> </ul>

### **0.3**

#### ***PROJECT AREA OF INFLUENCE***

The area affected by the Project and the infrastructure to be built includes the following:

- Land to be procured by NBBL for the power plant and access road in Kutuba Union;
- Existing land available within the premises of BPDB to be leased to NBBL in Kutuba Union;
- Right of Way of the gas pipeline up to Shahbazpur Gasfield at a distance of 5 km from the project location;
- Approach from Tetulia river up to Bhola II via Dehular Canal; and
- Area to be made available by BPDB within the premises of Bhola I.

In order to ascertain the project's area of influence, a study area of 5 km from the project site was considered (to incorporate the gas pipeline, Dehular canal as well as the local approach road from Burhanuddin town). The Area of Influence (AOI) of the Project comprises of the Project Site and the surrounding area, where influence of the Project activities is anticipated. The areas likely to be affected by the Project and its associated activities may include:

- the project activities and facilities that are directly owned, operated or managed by the project proponent (including by contractors) and that are components of the project, such as the power plant, gas pipeline, water pipelines and transmission line to the power grid sub-station;
- impacts from unplanned but predictable developments caused by the project that may occur later or at a related location such as increase in traffic on the approach road;
- impacts on biodiversity or on ecosystem services upon which affected communities' livelihoods are dependent;
- associated facilities, that are not funded as part of the project and that would not have been constructed or expanded if the project did not exist and without which the project would not be viable; and
- cumulative impacts that result from the incremental impact, on areas or resources used or directly impacted by the project, from other existing, planned or reasonably defined developments at the time the risks and impacts identification process is conducted i.e. existing Bhola-I CCPP, proposed Bhola-II CCPP in the surroundings

The analytical framework for interpreting and assessing the baseline data refers to the sustainable livelihoods framework <sup>(1)</sup>, which focuses on putting people at the centre of development. The baseline therefore describes the interrelated resources and receptors, which in the livelihoods framework are termed as 'capital' across five broad areas of resource and receptors on which livelihoods depend, i.e. social capital, natural capital, economic capital, physical capital and human capital.

(1) "A livelihood comprises the capabilities, assets (including both material and social resources) and activities required for a means of living. A livelihood is sustained when it can cope with and recover from stresses and shocks and maintain or enhance its capabilities and assets both now and in the future, while not undermining the natural resource base." (UK Department for International Development - DFID)



### *Social Baseline*

The socio-economic baseline has been developed on the basis of integrating existing quantitative data with some additional qualitative assessments that was undertaken through primary data collection as illustrated subsequently.

Figure 0.4 Methodology for the Socio-economic Baseline

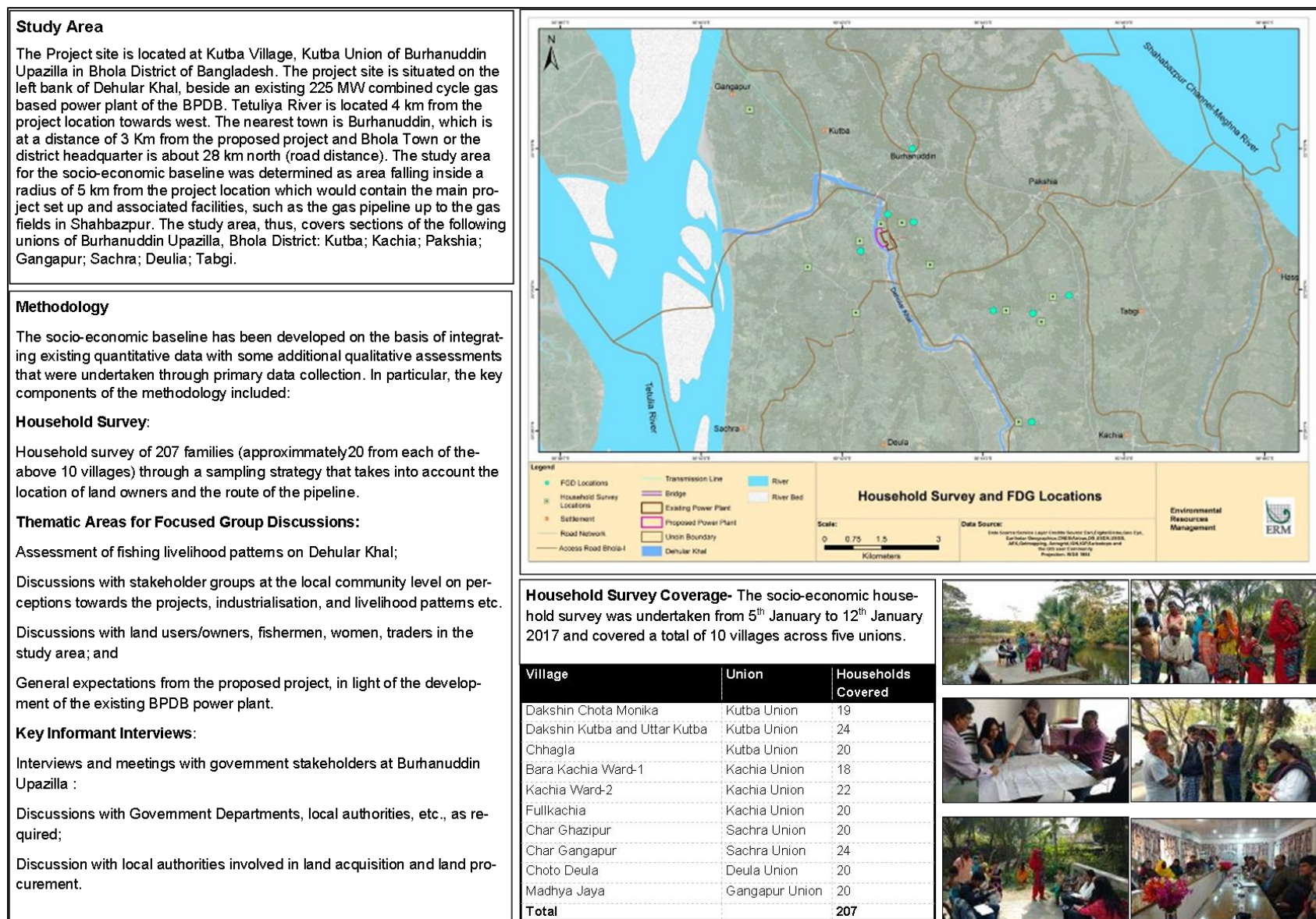


Figure 0.5 Summary of the Socio-economic Baseline

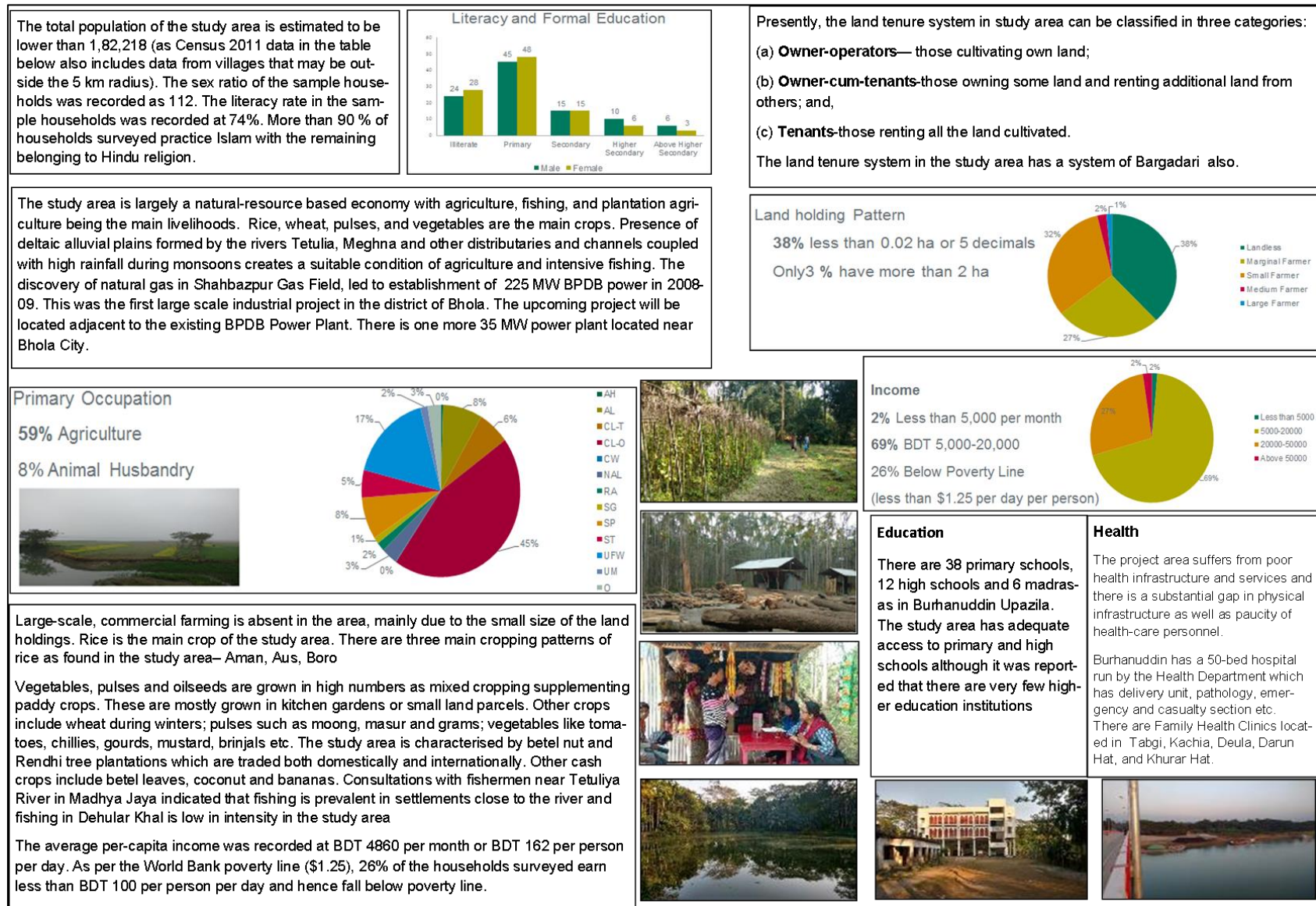
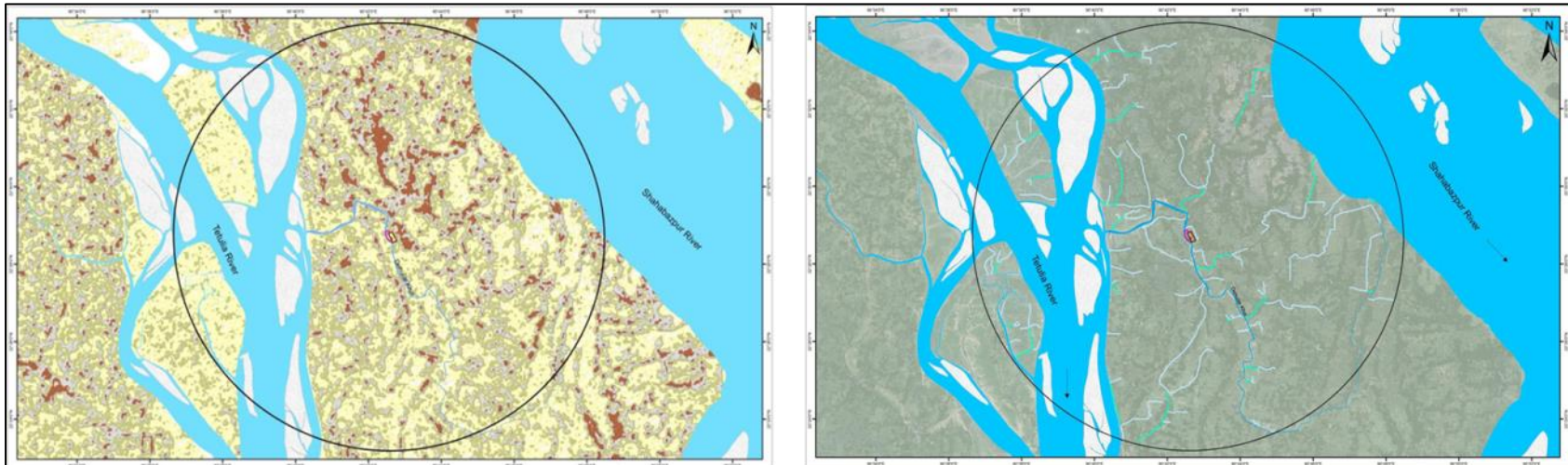




Figure 0.6 Summary of the Environmental Profile

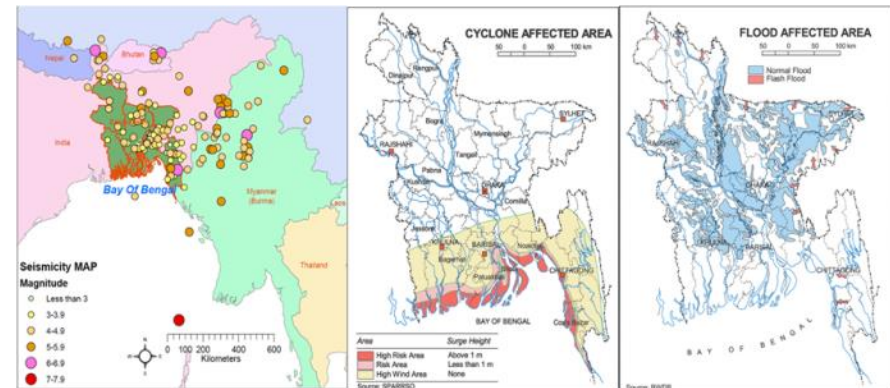


Contour map derived from the Digital Elevation Map (shown on the left) shows that the topography of the 10 km study area is predominantly flat terrain with a maximum elevation in the northern part of the bank of Tentulia River. There is no net downward slope at site with change in slope across the 10 km study area measured at less than 1% in most areas.

Bhola Island falls under the Ganges tidal flood plain and young Meghna estuarine floodplain and has a network of large number of tidal rivers and their tributaries. Sixty five square kilometers of the 10 km study area is covered by rivers and other water bodies. A perennial channel branching out of Tentulia River is Dehular Khal that flows adjacent to the project site.



The geology of the project area is primarily estuarine deposits and tidal deltaic deposits. Small mounds of tidal mud are also found at the southern parts of Bhola Island.



The project site is not located in a seismic hazard zone but is in a high risk cyclone area and is prone to flooding. Bhola Island is in a high risk zone for cyclone damage and faces storm surges of above 1 m in height. The site is also affected by flood water during the monsoon season because of the proximity to Dehular Canal. The site comes under 0.6 to 1.2 m of water for a few days during the peak monsoon season.



Figure 0.7 Summary of Soil and Water Quality

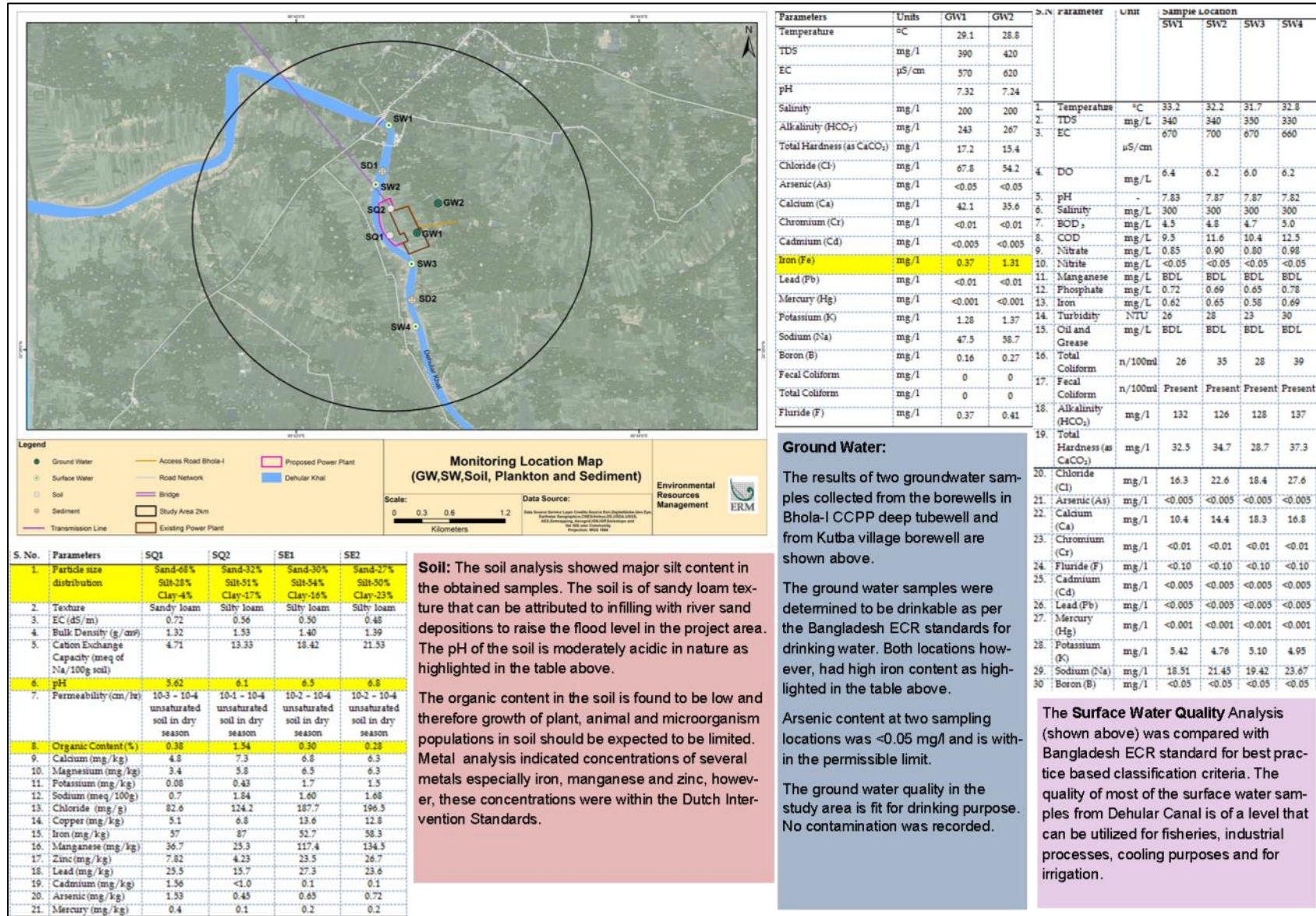




Figure 0.8 Summary of Air and Noise Quality

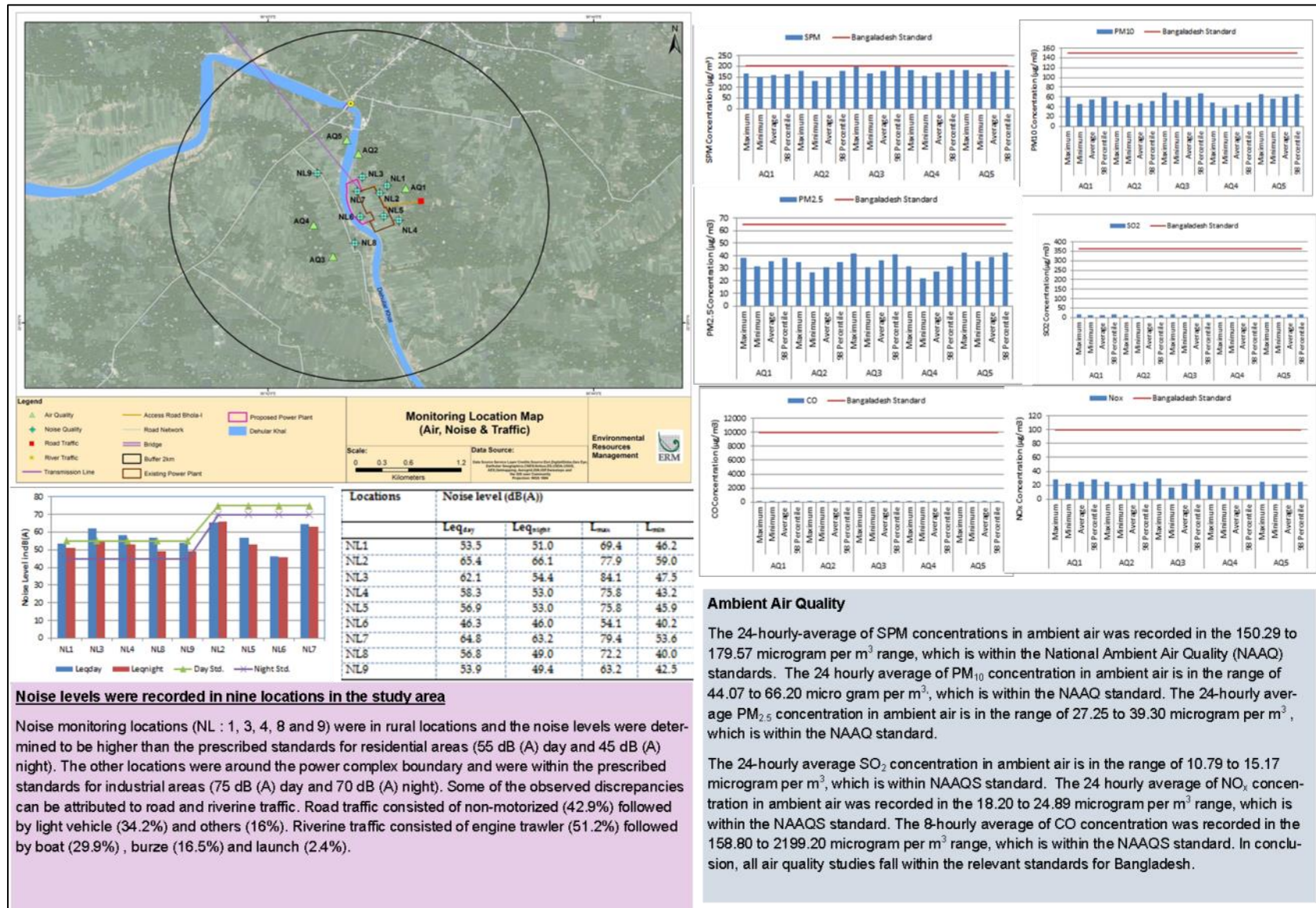
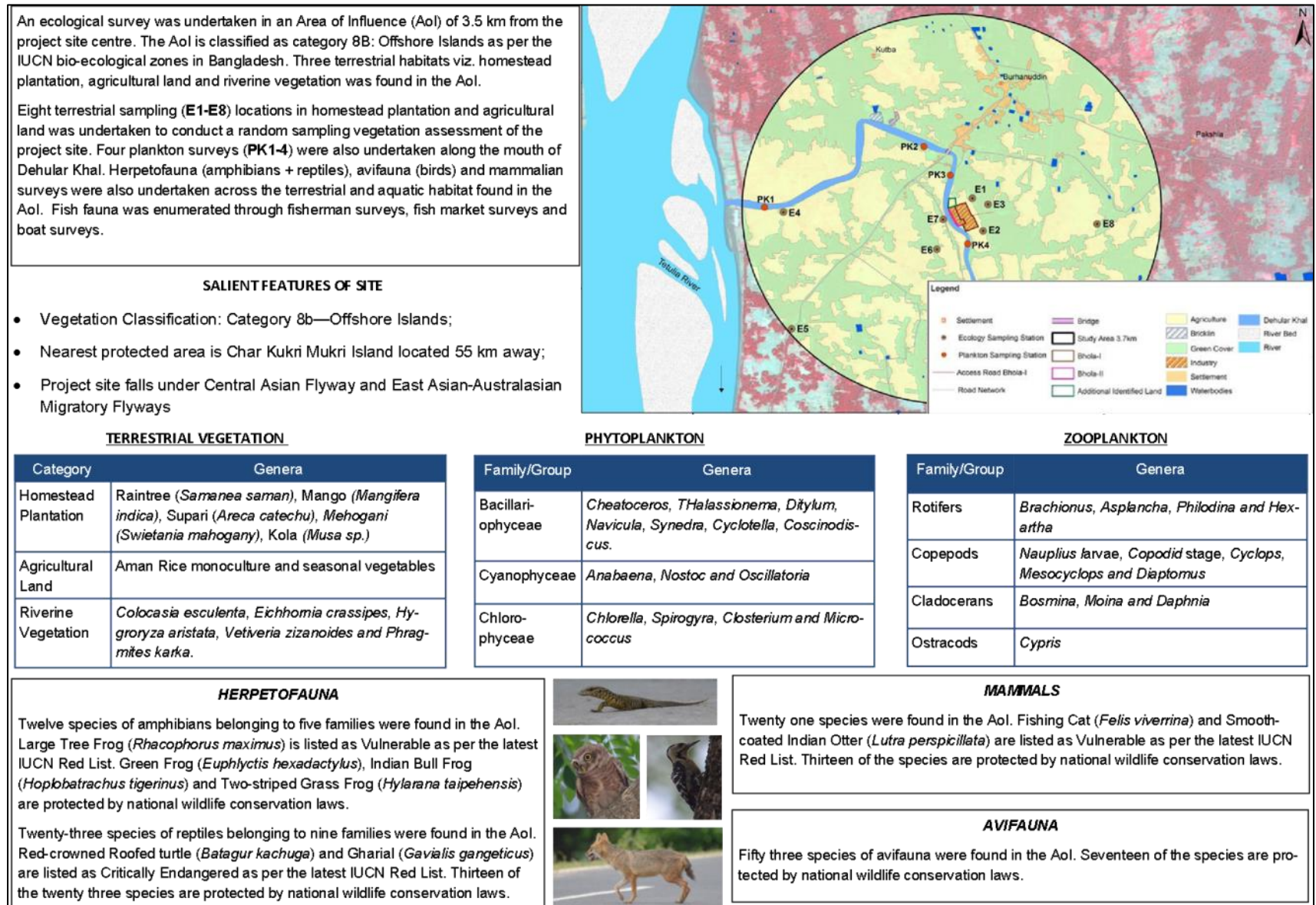


Figure 0.9 Summary of Ecological Profile



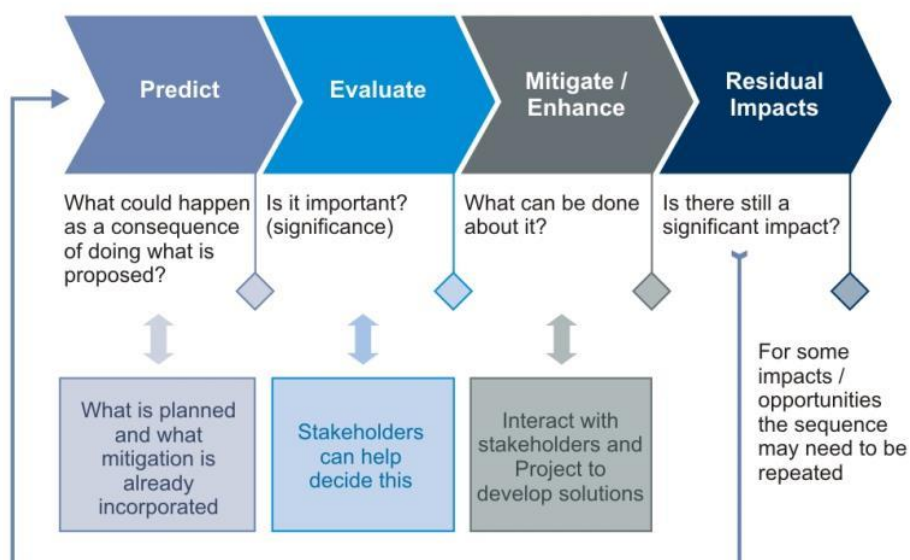


*Approach*

The impact assessment process comprised of the following steps:

- The potential impacts of Bhola II were initially identified during the scoping phase;
- Thereafter, environment, ecological and socio-economic baseline studies were undertaken to understand the likely changes that may occur during the construction and operations of Bhola II within a defined study area;
- Meetings were held with local communities and key informants to share information, answer questions and understand and respond to concerns about the Project (a process called 'Stakeholder Engagement' which is described further below);
- Specialist experience and knowledge, coupled with modelling (e.g. air quality) in some cases, was used to quantitatively and qualitatively assess which impacts will cause the most significant adverse changes as a result of Bhola II. The implications of the operations of Bhola I in conjunction with Bhola II were also understood for specific environment receptors;
- Measures of reducing the adverse changes and enhancing project benefits were also identified and discussed with the project proponent;
- Based on the above, a project and context specific Environmental and Social Management Plan was prepared for NBBL and their contractors.

**Figure 0.10** *Impact Assessment Process*



Impacts were assessed by specialists to understand their significance or importance for those affected by the project. The significance levels used for this assessment are described subsequently:



Significance	Levels
Negligible	There will be no or very limited impact.
Minor	There will be a small impact of limited concern or interest.
Moderate	There will be a moderate change to the environment and people that will be of some concern, and efforts will need to be made to manage these to the extent possible.
Major	There will be a very large change to the environment or people which will be of great concern, and which will need a great deal of effort to be managed.
Positive	There will be a positive impact.

### Environmental Impacts

During the construction phase of the Project, the key environmental issues are noise and dust generation. There is also a risk of contamination of soil, groundwater and the Dehular Khal from accidental spills and leaks of hazardous materials (e.g. oil) during handling, transportation, and storage at the site.

Various mitigation measures have already been developed by the Project Developer, as part of their “*Master Specification Manual*” for the EPC Contractor. The adverse impacts identified are generally manageable through good housekeeping and a diligent implementation of the ESMP by the EPC Contractor and its supervision by the Project Developer and their team of consultants. The nearest air quality and noise sensitive receptors will be a focus for monitoring of any impact arising due to the construction activities.

During the operation phase of the Project, the two key impacts will be from the increase in ambient noise and air quality levels due to operation of plant equipment and auxiliary machinery. It has been demonstrated through air quality dispersion modelling with natural gas as primary fuel as well as HSD as secondary fuel, the incremental ground level concentrations due to the operation of the Plant will be well within the applicable ambient air quality standards. Continuous emission monitoring from the stacks and periodic ambient air quality monitoring throughout operations will confirm compliance to the applicable standards/ guidelines and enable identification of further measures to reduce impacts to ALARP. Incremental noise levels due to the operation of Plant will meet the applicable GOB standards/IFC guidelines for industrial areas. However, the nearest noise sensitive receptors will have slightly higher noise levels than the applicable standards/ guidelines due to the higher background noise levels which are resulted primarily due to anthropogenic activities.

Induced draft cooling towers have been proposed in the project to reduce the water intake and outfall. About 75 m<sup>3</sup>/hr of cooling tower blowdown and treated wastewater will be discharged into Dehular Khal. The cooling tower blowdown will maintain increase in temperature difference between intake and outfall water temperature < 3°C and due to that the warming of surface water will be limited to a smaller area at outfall location, which will mix within a short distance (< 50 m) from the outfall location. A surface water

quality monitoring program, along with quarterly monitoring of aquatic ecology and fisheries has been formulated to further understand the extent of impact, if any, and to alert NBBL to take additional mitigation measures.

#### *Cumulative Environmental Implications*

The existence of the BPDB CCPP Power Plant (Bhola I) is an important aspect of the environment, ecological and socio-economic baseline, especially in view of the local community's perceptions towards the land procurement process, community health & safety, impacts to environmental parameters, employment and business opportunities and land-use change.

Some of the key impact conclusions are as follows:

- **Combined water requirement** of Bhola-I and II projects will be about 800 m<sup>3</sup>/hr at the time of operations. Based on the previous study, average discharge of Dehular Khal is about 108 m<sup>3</sup>/s. Total water abstraction quantity is therefore only 0.2% of the average flow of Dehular Khal and hence, the impact of water abstraction on Dehular Khal for the proposed plant would be **negligible**;
- The total treated **wastewater discharge** from the complex will be about 175 m<sup>3</sup>/hr, which will be discharged from the respective plant to the Dehular Khal after treatment. In the event that effluent discharge is detected above the effluent discharge limit criteria, isolation valves will automatically close and stop the discharge and hence, the impact is assessed as minor;
- For **ambient air quality**, the maximum ground level concentration (maximum baseline concentration + predicted maximum concentration) in the project AOI **with natural gas** as fuel will be within the applicable air quality standard and hence, impact significance due to operation of Bhola I and II projects with natural gas as fuel is assessed to be negligible;
- For **ambient air quality, while using HSD** as fuel, the maximum ground level concentrations (maximum baseline concentration + predicted maximum concentration) of NO<sub>x</sub>, SO<sub>2</sub> and PM<sub>10</sub> will be within the applicable standard and overall project contribution will be < 25% of the applicable standard. Therefore, using the operation of NBBL project using HSD as fuel along with Bhola I is assessed to be negligible;
- As per the latest report (26 December 2012) of **GHG emission** submitted by Bangladesh to the United Nations Framework Convention on Climate Change (UNFCCC)<sup>1</sup>, electricity generation sector contribution to GHG emission in year 2005 was 1.192 x 10<sup>7</sup> tons CO<sub>2</sub>e and projection of aggregate GHG emissions using LEAP modelling program indicates that the annual GHG emissions from this sector in year 2020 and 2030 will be 2.752 x 10<sup>7</sup> tons CO<sub>2</sub>e and 5.9168 x 10<sup>7</sup> tons CO<sub>2</sub>e, respectively. Taking this into consideration, GHG emission contribution of the Power Generation Complex (with total power generation capacity of about 450 MW) in the

<sup>1</sup> <http://unfccc.int/resource/docs/natc/bgdnc2.pdf>

year 2020 will be 5.38% of the electricity generation sector in Bangladesh. Considering this fact, the GHG emission impact will be moderate;

- Impact on ambient noise levels due to the operation of Bhola-I and Bhola-II projects were also evaluated by using noise prediction model. Ambient noise levels due to operation of both projects will be within the applicable standard during day time. The cumulative noise impact from NBBL operation during day time is expected to be **negligible to minor**. Furthermore, noise levels at night time will be higher than the applicable standard (with < 5 dBA increase from the applicable standard) a. Due to this the cumulative noise impact during night time is expected to be **minor to moderate**.

*Figure 0.11 Existing Bhola I Premises*



#### *Ecological Impacts*

For ecological impacts, interactions that are likely to lead to impacts on ecology and biodiversity within the study area are presented as follows:

- Construction Phase:
  - Loss of Habitat due to:
    - Clearance of vegetation, waste construction material in the 11.5 acres area;
    - Clearance of Vegetation in additional area of 5.78 acres for plant and access road and 5.5 acres for ROW of 6 km long gas pipeline; and
  - Habitat Disturbance:
    - Jetty development on Dehular Khal close to project site
    - Raising of project site by dredging Tentulia river;
    - Barge Movement for transportation of construction material
- Operations Phase:
  - Habitat Disturbance due to:
    - Water intake for plant operations from Dehular Khal and release of cooling tower blow down water in the same;
    - Transportation of HSD for plant operations;

The project will entail loss of habitat and vegetation clearance during the construction phase due to dredging of Dehular Khal, dredging of sand and

transport of material up to the project location and jetty development. During the construction and operations phase, accidental spillage of oil and chemical may lead to habitat disturbance. However, it has been assessed that this will not lead to a significant impact on aquatic ecology, fish resources and thereby fishing livelihoods and incomes and hence, the overall significance during construction is assessed to be **minor**, whereas for operations, it is assessed to be **minor to moderate**. Some of the proposed mitigation includes:

- Pre-construction survey for the project site by Herpetofaunal experts is required and clearance of existing scrap material should be done with support of a certified snake catcher for rescue of any species found. Similar arrangement should be made for the pipeline RoW;
- In case of bank erosions due to movement of barges and vessels used during construction and/or operation phases, NBBL shall invest in bank protection at both sides between Kheya Ghat to the project site as the movement of large barges and vessels will create swells and may erode the Khal banks and increase the turbidity in Khal;
- NBBL will need to ensure that stakeholder engagement is undertaken to ascertain that access to fishing grounds and transportation by boats from Dehular Canal up to Tetulia river is not impacted;
- Usage of barrier nets (seasonal or year-round), fish handling and return systems, fine mesh screens, and wedge-wire screens, and aquatic filter barrier systems should be explored in the water intake system;
- Usage of biocides should be reduced and kept to the extent required. Monitoring of the same in waste water discharge is suggested before reaching Dehular Khal.

*Figure 0.12 Biodiversity Features*



*Physical and Economic Displacement*

Development of the Project will cause physical displacement of some households in the local communities of Kutuba and Kachhia Union (approximately 5 households). In addition, approximately 63 land owners and 25 land users have been economically displaced by the land requirement for the power plant. The right of way acquisition of the gas pipeline will additionally impact approximately 132 land owners and users, however, this impact will be limited and is assessed as **minor** due to the route of the pipeline

being largely adjacent to the existing BPDB gas pipeline, thus minimizing land requirement.

A Resettlement Framework has been prepared in order to implement mitigation measures to compensate the impacts of physical and economic displacement through a focus on project-assisted self-relocation and Livelihood Support Plan.

#### *Livelihood Impacts for Fishermen*

During the construction phase, sand from the Tetulia River will be required for raising the level of the site from the existing level. Dredging may be required for the same; this may temporarily drive away the fish. However according to the Upazila Fisheries Officer this will eventually help in fish migration and breeding of fish in the river. According to the Fisheries Officer dredging will help to remove the natural obstruction under water which will help in easy movement of the fish and fish breeding.

During the operations phase, NBBL's power plant will discharge water into Dehular Khal. Discharge water from the power plant will be 2 to 3<sup>o</sup> C higher than the normal water temperature of the khal. Presently, there is limited thermal plume modelling to ascertain the cumulative impact of the effects of BPDB and NBBL's inlet and outlet. However, it is understood that the intensity of fishing in Dehular Canal is not major and that it is used for subsistence fishing for self-consumption or as a way to reach the Tetulia river where a majority of the fishing activity is carried out.

**Figure 0.13** *Artisanal Fishing Activities*



Fish resources and fish catch will need to be monitored through the construction and operations phase. For the latter, it is recommended that a thermal plume modelling is undertaken with focus on aquatic ecology and fishing implications by considering the inlet and outfall of BPDB and NBBL's water intake systems. Overall, the local community depends on Tetulia river for fishing and hence, while there is likely to be minor disturbance during construction, there is no significant disruption to fish resources and their availability.

### *Community Health and Health & Safety*

The potential health impacts due to a change in the environmental conditions are expected to be of a temporary nature, restricted to the project site and their immediate vicinity. Keeping this in mind, the health and safety impact associated with changes in environmental quality is considered to have *moderate* significance when assessed against the receptors location and the various mitigation measures in place.

### *Influx and In-migration*

During the construction phase there will be impact from migration of labour into the Project area, construction activities and increased movement of traffic. The range of impacts identified include: conflicts with the local community, health and safety issues inconvenience due to vehicle movements, risk of spread of communicable and sexually transmitted diseases, waste disposal and unhygienic conditions. The magnitude and significance of most of these impacts would be limited to the construction period, with limited spill over to the operation phase.

As the project intends to have a construction camp outside the premises of the allotted land, the interaction between the community and migrant workers would require to be monitored.

The Project will develop a Labour and Influx Management Plan (LIMP) that addresses how the Project will seek to: minimise Project-induced in-migration as far as possible; manage and direct the flow of in-migrants in accordance with the regional planning objectives; and implement mitigation measures to address the adverse environmental and social consequences, and maximise the benefits, of in-migration.



Figure 0.14 Overview of E&S Impacts

Key Impacts	Type of Impact	Significance Pre-Mitigation	Significance Post Mitigation
<b>Construction Phase</b>			
Soil and sediment impacts	Negative	Minor	Negligible
Air quality degradation (dust and exhaust)	Negative	Moderate	Minor
Noise from Construction Activities	Negative	Minor to Moderate	Negligible to Minor
Waste water discharge	Negative	Minor	Negligible
Ground water contamination	Negative	Minor	Negligible
Loss of land and land-use change	Negative	Minor	Negligible
Habitat Disturbance	Negative	Negligible to Minor	Negligible
<b>Operations Phase</b>			
Water pollution from wastewater discharge	Negative	Negligible	Negligible
Ground water contamination	Negative	Minor	Negligible
Ambient Air Quality (by use of HSD as fuel)	Negative	Negligible	Negligible
Noise from Operation of Plant and vehicles	Negative	Minor to Moderate	Minor
Risks of industrial accidents and fatalities	Negative	Minor	Negligible
Habitat Disturbance	Negative	Minor to Moderate	Minor
<b>Socio-economic Impacts</b>			
Physical and Economic Displacement	Negative	Moderate	Minor
Influx and in-migration	Negative	Moderate	Minor
Community health and health & safety	Negative	Moderate	Minor
Impact on fishing communities	Negative	Minor	Negligible
Fragmentation and Linear Impacts	Negative	Moderate	Minor
<b>Cumulative Implications (Bhola I and II)</b>			
Surface water abstraction	Negative	Negligible	Negligible
Water Pollution from Wastewater Discharge	Negative	Minor	Negligible
Ambient Air Quality with natural gas as fuel	Negative	Negligible	Negligible
Ambient Air Quality with HSD as fuel	Negative	Negligible	Negligible
GHG emissions	Negative	Moderate	Moderate
Noise from Operation of both projects	Negative	Minor to Moderate	Negligible to Minor



The present installed generation capacity in Bangladesh as on 1 January 2017 is 13,151 MW, which includes 600 MW of imported electricity. In addition to this, there is captive power generation of about 2,200 MW. The GOB has given highest priority to power sector development in the country and has committed to making electricity available to all citizens by 2021, including significant development programs for participation of the private sector. Bhola II (in conjunction with Bhola I) is one of the Greenfield projects that has been proposed to realise the above strategy. Overall, the annual electricity generation is expected to be ~1,696 million kW-hr.

Bhola II will provide reliable power supply to the region and will also bring about ancillary development, such as industrialisation in sectors such as small and medium scale manufacturing. The project development of NBBL's power plant in addition to BPDB's existing power plant will enable local economic benefits linked to employment generation, local procurement, encouragement of local enterprise development and skill development within the communities.

In addition, by specific stakeholder engagement activities and community development programs, the Project will further enhance the good will and cooperation of the community. The Project in its entirety can bring prosperity and development into the region and pave the way for further industrialisation in sectors such as food and fish processing, local manufacturing etc.

A number of mitigation measures to manage adverse impacts and recommendations to enhance benefits are captured in the Environmental and Social Management Plan (ESMP) for Bhola II. The ESMP also includes the following:

- Environmental Monitoring Plan;
- Framework Social Management Plans:
  - Stakeholder Engagement and Grievance Redressal Management Plan;
  - Resettlement Framework;
  - Gender Action Plan; and
  - Labour and Influx Management Plan;

The ESMP and other management plans have been developed in accordance to the requirements of regulations in Bangladesh, the expectations of the Terms of Reference provided as a part of the IEE Approval and good international industry practice, notably the IFC Performance Standards (2012). The ESMP and other plans will be implemented during construction and operation of the project. The ESMP takes each of the impacts identified in the



impact assessment of the ESIA and sets out the management measures needed to deal with the impacts as well as describing responsibility for implementing these.

**Box 0.4** *Important Implementation Commitments*

---

 <p>Formal HSSE Organisation Structure</p>	 <p>Resettlement and Livelihood Support Plan</p>	 <p>Ongoing Information Disclosure</p>
 <p>Inclusion of ESMP Commitments for Contracts</p>	 <p>Access to a Grievance Mechanism</p>	 <p>Resource and energy efficiency opportunities</p>
 <p>Ongoing monitoring and review of ESMP</p>	 <p>Report Disclosure</p>	 <p>Regular update and tracking of legal requirements</p>

---

**0.7** *STAKEHOLDER ENGAGEMENT*

*Engagement Process to Date*

Many of the stakeholders in the area of influence have been consulted at various times since January 2016 directly by NBBL as a part of the project development process, the land procurement process or to undertake the ESIA. The Project has established a partnership with the local and regional authorities in Burhanuddin, Bhola and Barisal as well as specific institutions such as the Sunderban Gas Company Limited and BPDB's Bhola I project team.

NBBL has undertaken verification of and consultation with land owners regarding ownership, inheritance and mutation of records between May 2016

to January 2017. This is being undertaken along with the Burhanuddin Upazila Chariman office and Land and Revenue department. Verification of mauza maps, drawings and on-field verification and ground-truthing of owner information was undertaken to correctly identify land ownership.

The land parcels have been identified and currently, 63 land owners have been identified who will be impacted due to land procurement for the power plant. 21 land sale agreements have also been executed with these land owners in January 2017 based on their signed consent to the rates per decimal that was negotiated at a Union level.

In the preparation of this ESIA, stakeholder engagement was undertaken in two rounds: a first round of engagement was conducted with stakeholders in April-May 2016 during the collection of environment and ecological baseline data. A second round of engagement was conducted with stakeholders in January 2017 during the collection of social baseline data. The stakeholders consulted included a sample of land owners, local community in the direct vicinity of the Project area, local elected representative such as the Upazila Chaimramn of Burhanuddin and the Union Chairmen of Kutba, Sachra and Kachia Unions, and other external stakeholders such as relevant government departments and NGOs.

#### *Key Issues and Concerns*

The main findings and observations from the consultation have been summarised here:

- There was some level of community health and safety issues within the local community with respect to traffic during construction phase, gas flare and the noise levels of existing BPDB power plant adjacent to the Project site (i.e. Bhola I);
- Due to the establishment of the BPDB Project, no restrictions as such were imposed in terms of access to Char land, grazing land, the river or any similar community resource;
- The land prices around the Project area have increased significantly due to the establishment of the existing BPDB plant. It is expected to rise further with the advent of this Project;
- The local fishermen representatives were of the opinion that the use of the Jetty area for vessel and material movement would result in a negative impact on the local community. This negative impact is likely to be resultant from a restriction on boat movement and use of nets, restriction on fishing activities during certain time periods and a decline in fish population and catch due to churning of river bed and siltation.

#### *ESIA Disclosure*

A Public Consultation Meeting was held on 6th March, 2017 at Upazila Auditorium, Burhanuddin Upazila Office, Burhanuddin to disclosure the key findings, impacts and proposed mitigation of the project. A presentation was

made on the Project, Nutan Bidyut (Bangladesh) Ltd. (NBBL) and on findings of the ESIA conducted followed by question and answer session.

**Figure 0.15** *Public Consultation Meeting, 6 March 2017*



*\*Source: Annex W*

The meeting was presided by Upazila Nirbhahi Officer (UNO), and attended by representatives from other Government Departments, Ward Councilors Burhanuddin Upazila and Union Parishads, Teachers, eminent citizens, senior citizens and NGO representatives. The people were notified about the meeting through invitation letters issued by the Project Proponent that outlined the purpose of the meeting along with date, time and venue; notices were also put up at prominent places in Upazila Office in advance.

#### *Next Steps*

Prior to commencement of construction on site, a grievance redressal mechanism will be put in place by which anyone with a complaint or a concern about the project, the land procurement process, NBBL's activities and the contractors' operations can be communicated. NBBL will disclose information on how to communicate a grievance and the system's accessibility using various forms of media. Once the Project receives a complaint from a stakeholder, they will receive a response to confirm this information has been received and the number of days within which they can expect a reply on the matter. It will be possible for people to submit a complaint without giving their name if they prefer.

During the construction phase, on-going engagement will take place through Community Liaison Officers (CLOs) that are a part of NBBL's HSSE team as well as representatives of the EPC contractors. This will be frequent, especially in terms of disclosure of ongoing activities and linked to activities such as transport of materials and equipment along Dehular Canal and the access road from Burhanuddin as well as the establishment of the offsite labour camp.

During operations, once construction is complete, engagement will become steady and routine over the years with the project-based operations teams. It will be important for NBBL to continue disclosure of specific benefits linked to

their community development activities and the grievance redressal mechanism.

## 0.8

### *CONCLUSION*

To conclude, a majority of the adverse the environmental and social impacts are localised, short-term or temporary although some of them are permanent in nature like health associated risks due to air emissions and effluent release, but can be mitigated with good design, appropriate application of mitigation measures and regular supervision of implementation of the Environmental and Social Management Plan (ESMP). Based on the analysis conducted in this environmental and social assessment, it is concluded that overall the Project will result in positive socio-economic benefits.

# 1 INTRODUCTION

## 1.1 INTRODUCTION

The Bangladesh Power Development Board (BPDB) and the Government of the People's Republic of Bangladesh (GoB) have taken initiatives to encourage private investment in the power sector especially for Gas based Combined Cycle Power Plants (CCPP). This has been backed by several proactive measures by the GoB to remove impediments and encourage private sector investment. In this context, Nutan Bidyut (Bangladesh) Limited (*hereinafter referred to as "NBBL"*), a subsidiary of M/s Shapoorji Pallonji Infrastructure Capital Company Pvt. Ltd. proposes to set up a dual fuel (Natural Gas and High Speed Diesel Oil) based CCPP of net capacity of around 225 MW as an Independent Power Plant (IPP) in Bhola District of Barisal Division, Bangladesh. The power plant is proposed to be located adjacent to the existing 225 MW CCPP of BPDB (Bhola-I).

According to the Bangladesh Environment Conservation Rules 1997 (ECR), power plants come under Red category and requires Initial Environmental Examination (IEE) and environmental impact assessment ("*EIA*") approval prior to start of construction activities at site. With respect to the same, NBBL had applied for IEE approval to Department of Environment (DoE), Bangladesh on 4 September 2016. The IEE presentation was held on 23 October 2016. Approval of Terms of Reference (ToR) for EIA study of the Project, was accorded vide DoE's Memo No: 22.02.1006.345.72. 012/474 dated 3 November 2016.

NBBL has commissioned ERM India Private Limited (*hereinafter referred as "ERM"*) to conduct this EIA study. This report has been prepared for NBBL by ERM and presents the objectives, methodology and outcomes of the EIA study in line with the applicable reference framework and approved ToR for EIA study by the DoE.

## 1.2 OVERVIEW OF THE PROJECT

### 1.2.1 *Need for the Project*

The supply of electricity has a great impact on the national economy of any country. Bangladesh, with its 152 million people in a land mass of 147,570 sq. km, has shown tremendous growth in recent years. A booming economic growth, rapid urbanization and increased industrialisation and development have increased the country's demand for electricity. Presently, 68% of the total population has access to electricity and per capita generation is 348 kWh, which is significantly lower when compared to other developing countries (Power Division 2015). The present installed generation capacity as on 1 January 2017 is 13,151 MW, which includes 600 MW of imported electricity. In addition to this, there is captive power generation of about 2,200 MW.

The GOB has given highest priority to power sector development in the country and has committed to making electricity available to all citizens by 2021 (Power Division 2015). The GOB has further extended its vision for power supply out to 2030 and prepared the Power System Master Plan (PSMP), 2010. The plan forecasts a supply surplus scenario by 2030 with power demand expected to be approximately 34,000 MW against a generation capacity of 40,000 MW (Power Division 2015). To realize these targets, the GOB since 2011 has undertaken the implementation of reforms in the power sector, including significant development programs for participation of the private sector of which this Project constitutes one of the important parts.

### 1.2.2 *Project Background*

The GOB has adopted a strategy for the development of the power sector which envisages private participation in the sector. As part of that strategy, the GOB decided that some new generation capacity will be installed and operated by the private sector.

In line with this strategy, the GOB decided to (a) implement a new greenfield 225 MW Combined Cycle Power Plant on Build, Own and Operate (“BOO”) basis under the GOB’s Independent Power Producer (IPP) program in Bhola District, Bangladesh (the “Project”); (b) to execute the Implementation Agreement (“IA”), the Power Purchase Agreement (“PPA”), the Gas Supply Agreement (“GSA”), the Fuel Supply Agreement (“FSA”) and the Land Lease Agreements (“LLA”), (together, the IA, PPA, GSA, LLA, and FSA are hereinafter referred to as the “Project Agreements”) and other contracts required for the financing, construction, operation and maintenance of the Facility; (c) implement the Project, and (d) upon Commissioning (combined-cycle mode), operate and maintain the Facility for a period of 22 years.

SP INFRA after a reconnaissance study and discussions with the BPDB and in due consideration of efficiency aspects, environmental considerations, availability of gas and space, has decided to set up a combined cycle power plant in Bhola Island (through its SPV NBBL), beside BPDB’s existing power plant (Bhola-I CCPP). A capacity of 225 MW has been decided in keeping with the land and fuel availability and similarity with the existing BPDB plant.

The Letter of Intent (LOI) for the development of project was issued by BPDB vide letter no. 1144-BPDB(Sectt.)/Dev-197/2010 dated 18 April 2016 (refer to *Annex A*).

### 1.2.3 *The Project – Bhola II*

The Project will be sited in Bhola Island, beside BPDB’s existing power plant (Bhola-I CCPP), in Bhola district. The Bhola District is the largest offshore island region in Bangladesh. The island is bounded by the Bay of Bengal to the south, Meghna River and Shahbazpur channel to the north and east, and Tentulia River to the west. The Project site is situated in Burhanuddin

Upazilla of Bhola District, which is approximately 28 km south from the Bhola Town. The location of the Project site is shown in *Figure 1.1*.

Land for this project has been earmarked by the BPDB, besides existing BPDB power plant. This identified plot (about 11.5 acres) is adequate for locating the gas based CCPP. However, as the project is now conceptualised with dual fuel arrangement and therefore, additional land ( Approx. 5.5 acres) is acquired for fuel storage and associated facilities including laydown area requirement during the construction phase. The plot of land is plain and flat, and a canal known as *Dehular Khal*, originating from Tatulia River, is passing alongside its western boundary. *Dehular Khal* has sufficient flow to meet the water requirement of the power plant for operation and maintenance throughout the year as well as for navigation.

The Plant is proposed to be operated on Natural Gas as primary fuel and High Speed Diesel (HSD) as a backup fuel in case of interruption on natural gas supply to the plant. The Natural Gas for the Power Plant will come from gas line of Sundarban Gas Company Ltd. (SGCL) from Shabazpur gas field which is at a distance of 6 km from the power plant site. Pipeline will be laid for this purpose by SGCL. New pipeline will be laid besides existing pipeline. It is understood that NBBL is presently evaluating two options as described in Section 2. The HSD required for gas turbines will be delivered by Bangladesh Petroleum Corporation (BPC). The oil will be delivered by oil tankers to the Jetty on the Dehular Khal.

The capacity of the total power plant has been finalized at 225 MW. Power would be available at 230 kV level in the existing 230 kV outdoor switchyard of BPDB's existing Power Plant. For the proposed project a new 230kV Gas Insulated Substation (GIS) will be constructed adjacent to existing outdoor 230kV switchyard. The existing sub-station will be connected to the new GIS and the total power evacuation of both the projects (existing BPDB project and proposed NBBL project) will be through the existing 230 kV overhead transmission lines to Barisal Substation and would be fed to the Power Grid Company of Bangladesh (PGCB) grid.

### **1.3 ABOUT THE PROJECT COMPANY AND SHAREHOLDERS**

#### **1.3.1 The Project Company – Nutan Bidyut (Bangladesh) Limited**

Nutan Bidyut (Bangladesh) Limited (“NBBL”) has been duly formed and registered under the Laws of the People’s Republic of Bangladesh on 27 March 2016 as a Limited company to develop, design, finance, build, own, operate and maintain the Plant. The Company has been set up for the sole purpose of developing, owning and operating the Project. Trade license of NBBL is included as *Annex B*.

### 1.3.2

#### *Parent Company – SP Infra*

Shapoorji Pallonji Infrastructure Capital Company Ltd. (SP Infra), a subsidiary of Shapoorji Pallonji Group was formed with the vision of developing excellent infrastructure assets. SP Infra has built on the group's strength in contracting, construction and financing of projects, and in near future aspires to become the major player in infrastructure development and operations in its chosen areas of business. SP Infra focuses on prospect, acquire, develop and maintain infrastructure assets meeting stakeholder requirements on a consistent, sustainable basis in chosen segments and businesses. Key focus sectors are:

- Energy, both conventional and renewable sources
- Ports
- Resource business
- Transportation

Key projects of the company (operational and/or under construction) are presented in **Box 1.1**.

#### **Box 1.1**

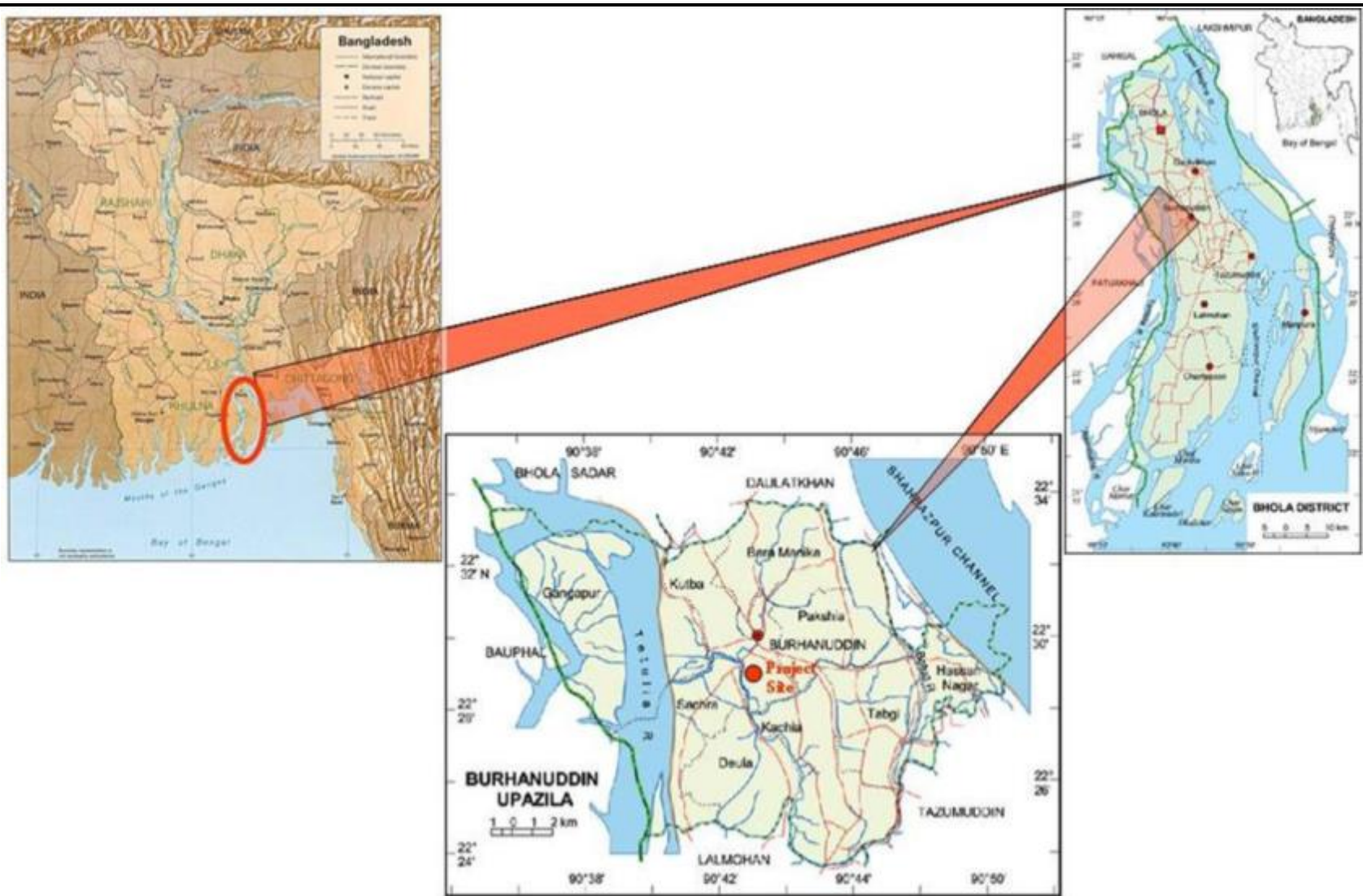
#### *Key Projects undertaken by SP Infra*

- **Kaj Power Plant:** SP Infra has financed the development of a 2640 MW imported coal based power plant in Gujarat, which will be based on super critical technology and would be implemented in two phases of 1320 MW each.
- **Samalpatti Power Plant:** A liquid fuel fired 105 MW power plant operational from 2001 to 2016 in Tamil Nadu, India - one of the early entrants to the privately financed power projects in India, currently under relocation to Sierra Leone.
- **Gokak Hydro:** 10.8 MW Hydro Power (Run-off-river project), Gokak Falls, Belgaum.
- **Tamil Nadu Solar:** Total 78 MW operational AC grid connected Solar PV power plant based on PPA signed with TANGEDCO.
- **Telangana Solar:** 10 MW AC grid connected Solar PV Project operational and 134 MW AC grid connected Solar PV Project under implementation in Telangana.
- **Egypt Solar:** 50 MW Solar Project in Egypt awarded under the renewable energy Feed in Tariff program.
- **Jammu-Udhampur Highway:** SP Infra developed a NHAI Annuity Project of four lanes of 64.542 km from Jammu to Udhampur in Jammu and Kashmir, India. This project achieved COD ahead of schedule in Jun2014.
- **Chhara Port:** Concession Agreement signed with GMB for 30 Years on BOOT basis for all weather deep draft Port in Gujarat (India).
- **LNG Terminal:** Being developed by HPCL Shapoorji Energy Pvt Ltd. (A JV Company of HPCL & Shapoorji Pallonji).
- **Trichy Tollway:** SP Infra developed a NHAI Toll project of four lanes of 94 km national highway from Ulundurpet to Padalpur in Tamilnadu, India.

Source: (SP Infra 2017)



Figure 1.1 Location of the Project Site



Source: Maps of Bangladesh (<http://mapof Bangladesh.blogspot.in>) and Local Government Engineering Department (LGED)

### 1.3.3 *Shapoorji Palonji Group – Sustainable Development Strategy*

The SP Group promotes sustainable development through four focus areas: (a) improve the quality of life; (b) promote inclusion and development; (c) provide education and skills training; and (d) preserve the environment. SP Group's pillars of sustainable development are presented in *Box 1.2*.

#### *Box 1.2 Pillars of the SP Sustainable Development Strategy*



Source: (SP Group 2017)

SP Infra has a Group EHS Management System in place, which is enforced across the Group, following ISO and OHSAS standards. Some of the group companies including the EPC division also have Certified EHS Management System (ISO 14001:2004 and OHSAS 18001:2007).

The HSE Management System with its associated Guidance Documents is mandatory for all entities under the management control of SP Group of Companies. Business units have the authority to meet the requirements of the elements with their existing processes, programs and systems (e.g. ISO 14001, OHSAS 18001) as long as conformance to the HSE Guidelines is demonstrated. The project will also follow these policies and guidelines and will plan specific action to align with them.

## 1.4 *IMPACT ASSESSMENT OBJECTIVES*

The objectives of this EIA are to:

- Facilitate an understanding of the elements of the existing baseline conditions that are relevant to resources/receptors that could be significantly impacted by the Project;
- Identify the aspects of the Project likely to result in significant impacts to resources/receptors;
- Document how stakeholders have been engaged during the EIA Process, and how stakeholder feedback has been considered in the EIA;
- Predict and evaluate the significance of the impacts of the Project;
- Identify the (environmental, social and health) aspects of the Project that need to be managed, and recommend appropriate and justified mitigation and enhancement measures;

- Determine the significance of residual impacts, taking into account the implementation of mitigation measures; and
- Generate plans for the management and monitoring of impacts, including plans for ongoing stakeholder engagement.

## 1.5 SCOPE OF EIA STUDY

### 1.5.1 *Applicable Reference Framework*

The reference framework for the EIA study will therefore be governed by the following standards/guidelines:

- Applicable Bangladesh national, regional and local regulatory requirements<sup>1</sup>;
- International conventions and agreements ratified by Bangladesh<sup>2</sup>.
- ADB's Safeguard Policy Statement (SPS) (2009)<sup>3</sup>;
- ADB Social Protection Strategy (2001)<sup>4</sup>;
- ADB's Public Communications Policy (2011)<sup>5</sup>;
- The IFC Performance Standards for Environmental and Social Sustainability (2012)<sup>6</sup>;
- The IFC General EHS Guidelines (2007)<sup>7</sup>;
- IFC EHS Guidelines for Thermal Power Plant (2008)<sup>8</sup>;
- The Equator Principles III (2013)<sup>9</sup>; and
- The Asian Infrastructure Investment Bank (AIIB) Environmental and Social Framework (2016)<sup>10</sup>.

### 1.5.2 *Coverage of EIA Study*

The coverage of EIA includes the 225 MW dual fuel combined cycle power project and its 5 km radius from centre of the Project site, the gas pipeline from Shabazpur gas field (about 6.0 km away from Project site), transmission line. The HSD required for gas turbines will be delivered from the refinery at Chittagong of Bangladesh Petroleum Corporation (BPC). The oil will be delivered by barges to the Jetty on the Dehular Khal. The Dehular Khal jetty

<sup>1</sup> Applicable Bangladesh Laws and Regulations are detailed in Chapter 3: Administrative Framework

<sup>2</sup> Applicable Bangladesh Laws and Regulations are detailed in Chapter 3: Administrative Framework

<sup>3</sup> <http://www.adb.org/documents/safeguard-policy-statement>

<sup>4</sup> <http://www.adb.org/documents/social-protection-strategy>

<sup>5</sup> <http://www.adb.org/documents/pcp-2011>

<sup>6</sup> [http://www.ifc.org/wps/wcm/connect/115482804a0255db96fbfd1a5d13d27/PS\\_English\\_2012\\_Full-Documents.pdf?MOD=AJPERES](http://www.ifc.org/wps/wcm/connect/115482804a0255db96fbfd1a5d13d27/PS_English_2012_Full-Documents.pdf?MOD=AJPERES)

<sup>7</sup> <http://www.ifc.org/wps/wcm/connect/554e8d80488658e4b76af76a6515bb18/Final+-General+EHS+Guidelines.pdf?MOD=AJPERES>

<sup>8</sup> [http://www.ifc.org/wps/wcm/connect/dfb6a60048855a21852cd76a6515bb18/FINAL\\_Thermal%2BPower.pdf?MOD=AJPERES&id=1323162579734](http://www.ifc.org/wps/wcm/connect/dfb6a60048855a21852cd76a6515bb18/FINAL_Thermal%2BPower.pdf?MOD=AJPERES&id=1323162579734)

<sup>9</sup> <http://www.equator-principles.com/index.php/equator-principles-3>

<sup>10</sup> [https://www.aiib.org/en/policies-strategies/\\_download/environment-framework/20160226043633542.pdf](https://www.aiib.org/en/policies-strategies/_download/environment-framework/20160226043633542.pdf)

will be utilised for transportation of roject related transportation activities during construction and operational phase.

### 1.5.3 *Scope of Work*

The detailed scope of the EIA study is as outlined below:

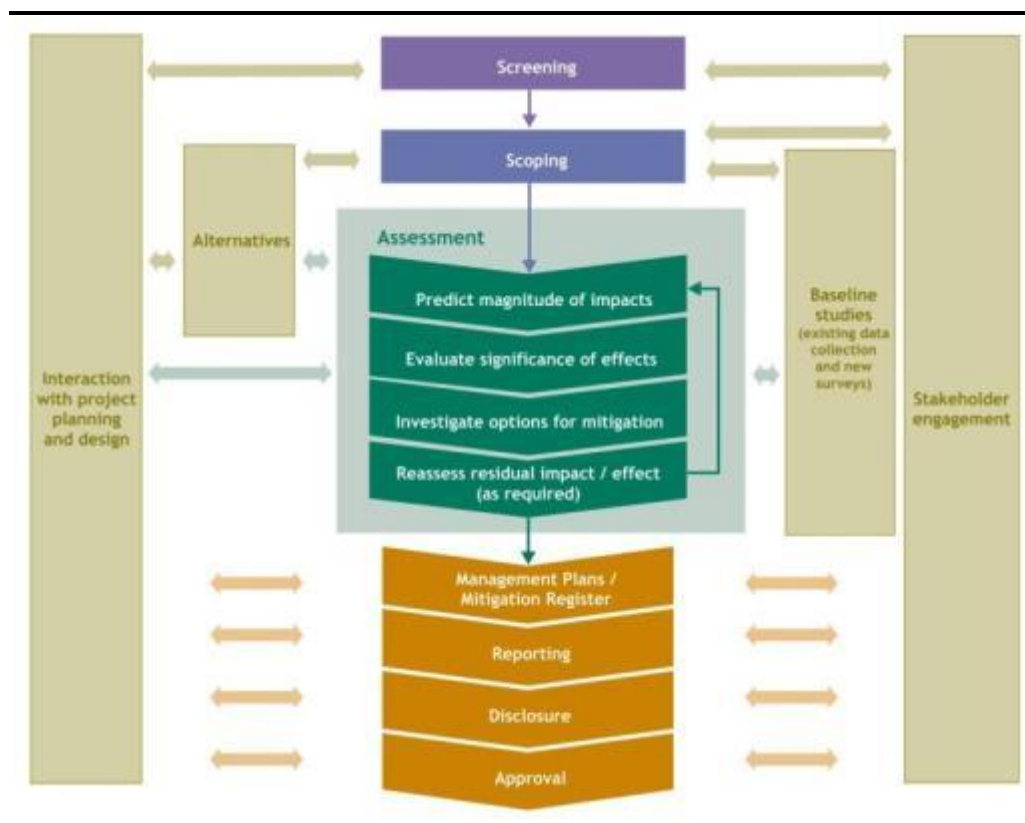
- Screening of the Project based on applicable reference framework based on reconnaissance survey and desk based review of Project documents;
- Scoping for the EIA study;
- Development of an integrated project description of the Project components including its sub-components, which are under the purview of the Project Proponent (PP);
- Development of a regulatory, policy and administrative framework relevant to the Project;
- Monitoring, analysis and reporting of the environmental and social baseline data of the study area including consultation with local communities and other stakeholders;
- Assessment of the environmental impacts of the Project in the study area;
- Assessment of social impacts on the local community as well as Project affected people and any other stakeholders, which have been identified during the social consultation process;
- Assessment of cumulative impacts due to the neighbouring Bhola-I CCPP based on available information;
- Risk assessment and consequence analysis of the Project;
- Formulation of an Environment and Social Management Plan and associated/specific mitigation plans for identified impacts; and
- Formulation of Public and Stakeholder Consultation and Grievance Redress Mechanism for the Project.

## 1.6 *APPROACH AND METHODOLOGY*

The EIA has been undertaken following a systematic process that predicts and evaluates impacts the Project could have on aspects of the physical, biological, social/socio-economic and cultural environment. Further, identifies measures that the Project will take to avoid, minimise/reduce, mitigate, offset or compensate for adverse impacts; and to enhance positive impacts where practicable. The EIA methodology follows the overall impact assessment approach illustrated in *Figure 1.2*.

The approach and methodology adopted for screening and scoping of the project is discussed below, while the approach and methodology for baseline data collection and assessment has been described in the beginning of the respective chapters of this report.

Figure 1.2 Impact Assessment Process



1.6.1 Screening

At the initial stage of the EIA, preliminary information was obtained and discussions held to aid in the determination of what legal and other requirements apply to the Project. This step was conducted utilising a high level description of the Project and its associated facilities.

1.6.2 Scoping

Scoping was undertaken to identify the potential Area of Influence for the Project (and thus the appropriate Study Area), to identify potential interactions between the Project and resources/receptors in the Area of Influence and the impacts that could result from these interactions, and to prioritize these impacts in terms of their likely significance. **Table 1.1** presents the resources/receptors considered in the scoping stage, together with the changes that could/might indicate a Project-related impact.

Table 1.1 Resources/Receptors and Impacts Considered in Scoping

Resources/Receptors	Impacts
<b>Environmental</b>	
Land Forms/Profile	Changes to <ul style="list-style-type: none"> <li>• Geology</li> <li>• Geomorphology</li> <li>• Topography</li> </ul>
Soil Quality	Changes to <ul style="list-style-type: none"> <li>• Physical and chemical properties</li> <li>• Soil ecology</li> <li>• Erosion</li> </ul>

<b>Resources/Receptors</b>	<b>Impacts</b>
Sediment Quality	<ul style="list-style-type: none"> <li>• River/waterbed morphology,</li> <li>• Physical and chemical properties,</li> <li>• Benthic organisms.</li> </ul>
Land use	<ul style="list-style-type: none"> <li>• Changes in Landuse/land cover profile</li> <li>• Logistics</li> </ul>
Air Quality	Emissions of
Climate Change	<ul style="list-style-type: none"> <li>• Gaseous pollutants (e.g. NO<sub>x</sub>, SO<sub>x</sub>, etc.); and</li> <li>• Particulate matter (e.g. PM<sub>10</sub> and PM<sub>2.5</sub>)</li> <li>• Greenhouse gases (CO<sub>2</sub>, CH<sub>4</sub>, and N<sub>2</sub>O) emissions,</li> <li>• Increase in global warming;</li> <li>• Flooding.</li> </ul>
Drainage Pattern	Changes in the
	<ul style="list-style-type: none"> <li>• Drainage pattern,</li> <li>• Submergence,</li> <li>• Floods etc.</li> </ul>
Surface Water Quantity and Quality	Changes to
	<ul style="list-style-type: none"> <li>• Physical, chemical or biological quality of Dehular River</li> <li>• Changes in surface water quantity</li> <li>• Changes in habitat quality, abundance, diversity;</li> <li>• Effluent discharge.</li> </ul>
Ground water Quality	<ul style="list-style-type: none"> <li>• Contamination of shallow or deep groundwater resources,</li> <li>• Change in ground water resource.</li> </ul>
Ambient Noise Levels	<ul style="list-style-type: none"> <li>• Change in noise levels</li> </ul>
Vibration	<ul style="list-style-type: none"> <li>• Changes in Vibration levels</li> </ul>
Waste	<ul style="list-style-type: none"> <li>• Generation of wastes-hazardous and non-hazardous</li> </ul>
Solid Waste and liquid waste	
Terrestrial Ecology	<ul style="list-style-type: none"> <li>• Impact on flora and fauna</li> </ul>
Aquatic Ecology (Biodiversity)	<ul style="list-style-type: none"> <li>• Changes in fisheries productivity and impact on aquatic form of various activities as dredging, water intake and discharge</li> </ul>
<b>Social/Socio-Economic</b>	
Demographics (i.e. Displacement)	Changes in
	<ul style="list-style-type: none"> <li>• Population, total population, gender ratio, age distribution.</li> <li>• Physical displacement from residence as a result of Project land take, or activities</li> </ul>
Economy and livelihood	Change in
	<ul style="list-style-type: none"> <li>• Local economy,</li> <li>• Employment,</li> <li>• Standard of living,</li> <li>• Occupation</li> </ul>
Social and Cultural Structures	<ul style="list-style-type: none"> <li>• Disruption in local authority and governance structure;</li> <li>• Change in social behaviours; alterations to social and cultural networks;</li> <li>• Intra and inter-ethnic conflict.</li> </ul>
Economy and Livelihood	<ul style="list-style-type: none"> <li>• Impact in Livelihood pattern.</li> </ul>
Infrastructure and Services	<ul style="list-style-type: none"> <li>• Improvement or pressure on existing urban/rural infrastructure or services including: transportation; power, water, sanitation, waste handling facilities etc.</li> </ul>
Cultural Resources	<ul style="list-style-type: none"> <li>• Physical disturbance of shrines, burial grounds, archaeological resources or other desecration;</li> </ul>
Social/Community Cohesion	<ul style="list-style-type: none"> <li>• Any social/community cohesions/ conflicts due to workers from outside or due to Project related activities</li> </ul>
Vulnerable Groups	<ul style="list-style-type: none"> <li>• Impact on livelihood, community networks, displacement induced impacts</li> </ul>
<b>Health</b>	



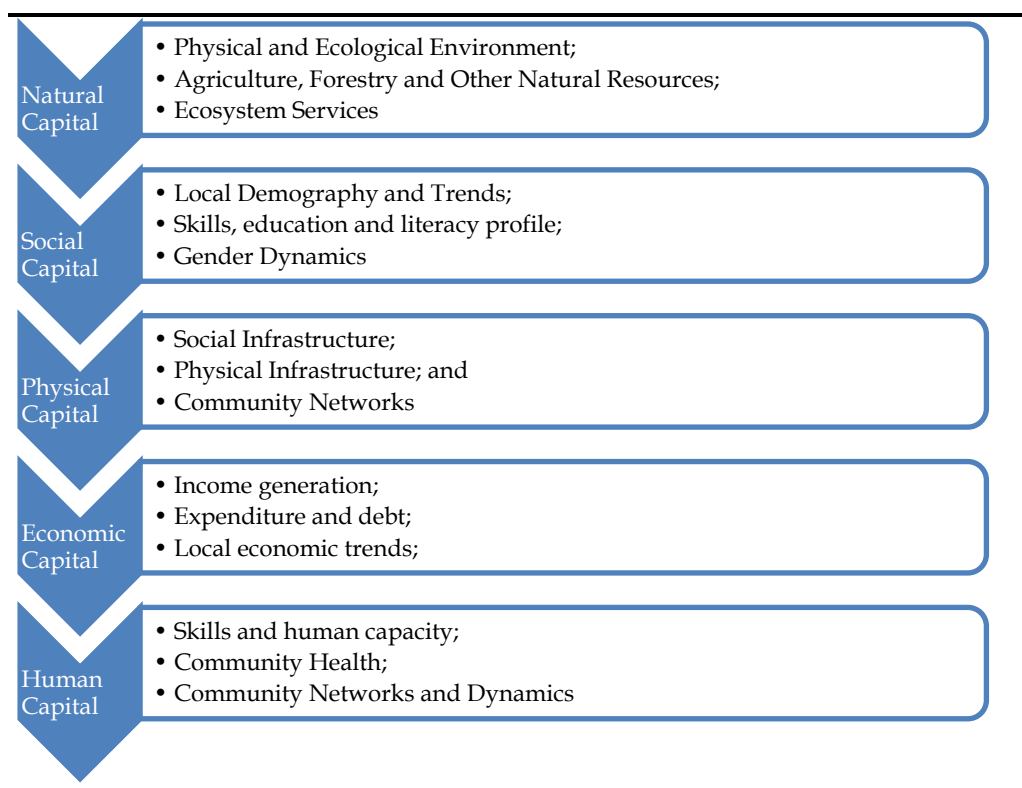
Resources/Receptors	Impacts
Community Health and Safety	<ul style="list-style-type: none"> <li>• Changes in the incidence and /or prevalence of sexually transmitted diseases and the factors that contribute to this (external workforce, transport routes etc. Changes in the incidence and or prevalence of vector borne diseases, the density of these vectors and their breeding grounds.</li> <li>• Changes in availability of and access to health care, nutritional status, food security etc.</li> </ul>

In addition to the above, the approved TOR for EIA study has also been taken into consideration to define the scope of the EIA study. Copy of approved TOR for EIA study is included as *Annex C*. The project has also taken no objection certificate (NOC) from the Union Nirbahi Officer (UNO) of Kutba Union and from the Upazilla Chairman of Burhanuddin Upazilla, which are included as *Annex D* and *Annex E*, respectively.

### 1.6.3 *Baseline Data Generation*

The primary objective of the environmental, ecological and socio-economic baseline study is to provide a baseline against which potential impacts from the construction, operation and decommissioning phases of the Project can be assessed. ERM has adapted the Sustainable Livelihoods Framework propagated by the Department for International Development (DFID) <sup>(1)</sup> to present the environmental, ecological and socio-economic baseline study.

**Figure 1.3** *Sustainable Livelihoods Framework*



(1) DFID Sustainable Livelihoods Guidance ([www.livelihoods.org](http://www.livelihoods.org))

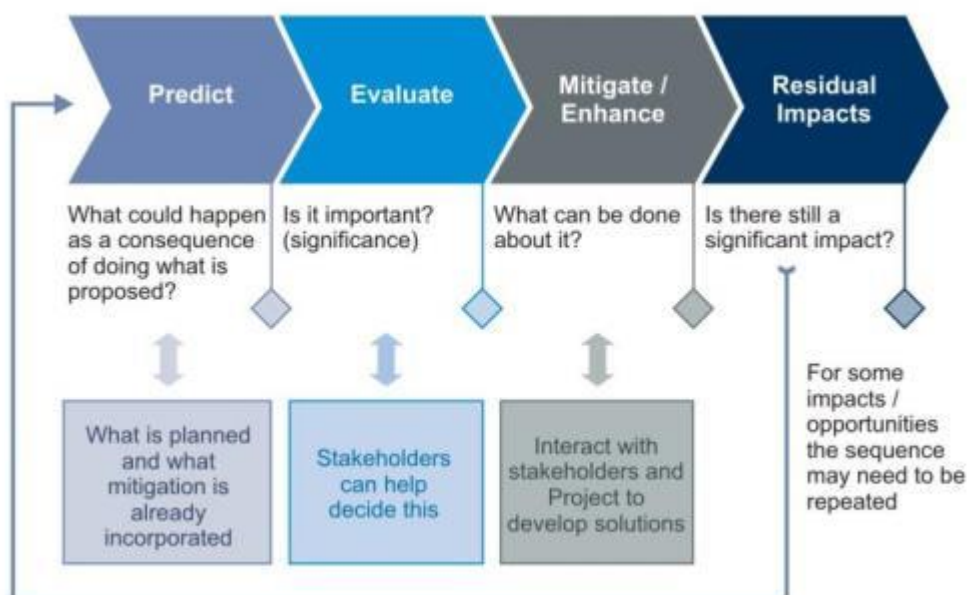
The methodologies of baseline data collection for the environmental, ecological and socio-economic baseline are presented in *Section 4.2* and subsequent sections of *Section 3* and *Section 5*.

#### 1.6.4 *Impact Assessment and Management*

Impact identification and assessment starts with scoping and continues through the remainder of the IA Process. The principal IA steps are summarized in *Figure 1.4* and comprises of:

- **Impact prediction:** to determine what could potentially happen to resources/receptors as a consequence of the Project and its associated activities.
- **Impact evaluation:** to evaluate the significance of the predicted impacts by considering their magnitude and likelihood of occurrence, and the sensitivity, value and/or importance of the affected resource/receptor.
- **Mitigation and enhancement:** to identify appropriate and justified measures to mitigate negative impacts and enhance positive impacts.
- **Residual impact evaluation:** to evaluate the significance of impacts assuming effective implementation of mitigation and enhancement measures.

*Figure 1.4 Impact Assessment Approach*



The detailed impact assessment methodology is presented in *Section 6.2*.

#### 1.7 *ESIA TEAM*

ERM constituted a team comprising of various experts to carry out the ESIA study as detailed out in the table below:



**Table 1.2 ESIA team and their roles**

S.No.	Name	Specialist
1.	Neena Singh	Project Director and Technical review for Social
2.	Debanjan Bandyopadhyay	Technical review for Environment
3.	Dr.Arun Venkataraman	Technical review for Ecology and Biodiversity
4.	Rutuja Tendolkar	Social Specialist and Project Manager
5.	Naval Chaudhary	Environmental Specialist (Air and Noise)
6.	Salil Das	Environmental Specialist (Water and waste)
7.	Dr.Rahul Srivastava	Ecology and Biodiversity Specialist
8.	Subhradeb Pramanik	Risk assessment Specialist
9.	Kazi Farhed Iqbal (EQMS)	Stakeholder Consultation, Baseline data collection
10.	Mohammad Mamun Chowdhury (EQMS Associate)	Fisheries Specialist
11.	Tauhidul Hasan (EQMS)	Baseline data collection
12.	Soumi Ghosh	Socio-economic baseline and stakeholder consultation
13.	Devanshu Bajpai	Stakeholder Consultation
14.	Dibyendu Chakraborty	GIS and mapping

## 1.8 REPORT STRUCTURE

The EIA report has been largely structured based on the ToR issued by DoE dated 3<sup>rd</sup> November 2016. The layout of the Report has been divided into 10 sections as briefly described in *Table 1.3*:

**Table 1.3 Layout of the Report**

Chapter No.	Chapter Title	Description
0	Executive Summary	This section includes <ul style="list-style-type: none"> <li>Brief summary of the entire EIA report</li> </ul>
1	Introduction	This section includes <ul style="list-style-type: none"> <li>introduction about the project,</li> <li>Project background,</li> <li>Brief description,</li> <li>Scope of the EIA study</li> <li>Approach and Methodology</li> <li>EIA team</li> </ul>
2	Policy, Legal and Administrative Framework	This section discusses <ul style="list-style-type: none"> <li>the national and local legal and institutional framework within which the environmental assessment is carried out. It also identifies project-relevant international environmental agreements to which the country is a party.</li> <li>it also covers the applicable reference framework being used for the EIA study in addition to the national regulatory requirements for project financing.</li> </ul>
3	Project Description	This section describes <ul style="list-style-type: none"> <li>the proposed project;</li> <li>its major components; and</li> <li>its geographic, ecological, social, and temporal context, including</li> <li>associated facility required by and for the project.</li> </ul> <p>This section also examines</p> <ul style="list-style-type: none"> <li>alternatives to the proposed project site, technology,</li> </ul>

Chapter No.	Chapter Title	Description
		design, and operation – including the no project alternative – in terms of their potential environmental and social impacts; the feasibility of mitigating these impacts; their suitability under local conditions; and their institutional, training, and monitoring requirements.
4	Description of the Environment	<ul style="list-style-type: none"> <li>• It also states the basis for selecting the particular project design proposed and, justifies recommended emission levels and approaches to pollution prevention and abatement.</li> </ul> <p>This section describes</p> <ul style="list-style-type: none"> <li>• relevant physical and biological conditions within the study area, and</li> <li>• looks at current and proposed development activities within the project's area of influence, including those not directly connected to the project. It indicates the accuracy, reliability, and sources of the data.</li> </ul>
5	Socio-economic Environment	<p>This section describes</p> <ul style="list-style-type: none"> <li>• relevant socioeconomic conditions within the study area, and</li> <li>• looks at current and proposed development activities within the project's area of influence, including those not directly connected to the project. It indicates the accuracy, reliability, and sources of the data.</li> </ul>
6	Anticipated Environmental and Social Impacts and Mitigation Measures	<p>This section</p> <ul style="list-style-type: none"> <li>• predicts and assesses the project's likely positive and negative direct and indirect impacts to physical, biological, socioeconomic (including occupational health and safety, community health and safety, vulnerable groups and gender issues, and impacts on livelihoods through environmental media, and physical cultural resources in the project's area of influence, in quantitative terms to the extent possible;</li> <li>• identifies mitigation measures and any residual negative impacts that cannot be mitigated; explores opportunities for enhancement; identifies and estimates the extent and quality of available data, key data gaps, and uncertainties associated with predictions and specifies topics that do not require further attention; and examines global, transboundary, and cumulative impacts as appropriate.</li> </ul>
7	Environmental and Social Management Plan (ESMP)	<p>This section deals with</p> <ul style="list-style-type: none"> <li>• the set of mitigation and management measures to be taken during project implementation to avoid, reduce, mitigate, or compensate for adverse environmental and social impacts;</li> <li>• describes the mitigation, monitoring, implementation arrangements and performance indicators for effective implementation of the ESMP; and</li> <li>• Framework management plans for construction phase of the project.</li> </ul> <p>This section also describes:</p> <ul style="list-style-type: none"> <li>• the grievance redress framework, setting out the time frame and mechanisms for resolving complaints about environmental performance; and</li> <li>• structure of the grievance redress cell to be formed for the project.</li> </ul>
8	Stakeholder Consultations and	<p>This section</p> <ul style="list-style-type: none"> <li>• describes the process undertaken during project design</li> </ul>

Chapter No.	Chapter Title	Description
	Participation	and preparation for engaging stakeholders, including information disclosure and consultation with affected people and other stakeholders; <ul style="list-style-type: none"> <li>summarizes comments and concerns received from affected people and other stakeholders and how these comments have been addressed in project design and mitigation measures, with special attention paid to the needs and concerns of vulnerable groups; and</li> <li>describes the planned information disclosure measures and the process for carrying out consultation with affected people and facilitating their participation during project implementation.</li> </ul>
9	Risk Assessment	This section entails risk assessment to personnel and environment from consequences of accidental events as well as natural hazards and includes: <ul style="list-style-type: none"> <li>Hazard Identification</li> <li>Consequence Analysis</li> <li>Risk Reduction Measures and Recommendations</li> </ul>
10	Conclusion and Recommendation	This section provides <ul style="list-style-type: none"> <li>the conclusions drawn from the impact assessment; and</li> <li>Recommendations for environmental and social management during the project lifecycle.</li> </ul>

The report is supported with the following Annexures:

Annex A	Letter of Intent
Annex B	Certificate of Incorporation
Annex C	Approved ToR by DoE (3.11.2016)
Annex D	NoC UNO Thana Parishad
Annex E	Upazilla NoC
Annex F	Screening against ADB SPS Checklists
Annex G	Water Treatment
Annex H	DM Plant Design Basis Report
Annex I	ETP
Annex J	STP
Annex K	Detailed Implementation Schedule
Annex L	EPC Contractor Profile
Annex M	Faunal Species

Annex N	Amphibian Species
Annex O	Reptile Species
Annex P	Avifauna Species
Annex Q	Mammal Species
Annex R	Fish Species
Annex S	Critical Habitats Assessment
Annex T	List of Land Owners
Annex U	Stakeholder Consultation Minutes
Annex V	Baseline Monitoring Reports
Annex W	Public Consultation Minutes
Annex X	Social Framework Management Plans

**2.1 INTRODUCTION**

To address the environmental and social risks of any proposed project and its associated components; to protect and conserve the environment from any adverse impacts, the GOB has specified regulations, policy and guidelines. This section focuses on the administrative framework under the purview of which the proposed Project will fall and the EIA study will be governed, namely:

- Bangladesh national and local, legal and institutional framework; and
- International agreements and conventions ratified by Bangladesh

It is understood that the Project is also intended to receive international financing for project execution and there are specific environmental and social safeguard requirements of international financial institutions. Considering that potential lenders will be following the safeguard requirements of ADB, IFC, Equator Principles Financial Insti, expectation of these safeguards has also been assessed as part of administrative framework:

- ADB Policies and framework;
- IFC Performance Standards and EHS Guidelines;
- Equator Principles; and
- AIIB Environmental and Social Framework.

**2.2 ENVIRONMENT-RELATED POLICIES IN BANGLADESH**

The GOB has developed a policy framework that requires environmental issues to be incorporated into economic development planning. The Key tenets of the various applicable policies are detailed in the following subsections.

**2.2.1 National Environmental Policy, 1992**

The Bangladesh National Environmental Policy, approved in May 1992, sets out the basic framework for environmental action together with a set of broad sectoral action guidelines. Key elements of the Policy are:

- Maintaining ecological balance and ensuring sustainable development of the country through protection, conservation and improvement of the environment;
- Protecting the country from natural disasters;
- Identifying and regulating all activities that pollute and destroy the environment;
- Ensuring environment-friendly development in all sectors;

- Ensuring sustainable and environmentally sound management of the natural resources; and
- Promoting active association, as far as possible, with all international initiatives related to environment.

The Environmental Policy of 1992 requires specific actions with respect to the industrial sector which are as follows:

- To phase-in corrective measures in polluting industries;
- To conduct EIAs for all new public and private industrial developments;
- To ban, or find environmentally sound alternatives for, the production of goods that cause environmental pollution; and
- To minimize waste and ensure sustainable use of resources by industry.

The policy also states that EIA's should be conducted before projects are undertaken and the DOE is directed to review and approve all Environmental Impact Assessments.

### 2.2.2 *National Environment Management Action Plan, 1995*

The National Environmental Management Action Plan (NEMAP) is a wide-ranging and multi-faceted plan, which builds on and extends the statements, set out in the National Environmental Policy. NEMAP was developed to address issues and management requirements related to the environment during the period 1995 to 2005; it also sets out the framework within which the recommendations of the National Conservation Strategy are to be implemented. NEMAP was developed to achieve the following broad objectives:

- Identification of key environmental issues affecting Bangladesh;
- Identification of actions necessary to halt or reduce the rate of environmental degradation;
- Improvement of the natural environment;
- Conservation of habitats and bio-diversity;
- Promotion of sustainable development; and
- Improvement of the quality of life of the people.

To attain the above mentioned objectives, the plan groups all the relevant necessary actions under four headings, namely: *institutional, sectoral, location-specific* and *long-term issues*.

The *institutional* aspects reflect the need of inter-sectoral cooperation to tackle environmental problems which need new and appropriate institutional mechanisms at national and local levels. The *sectoral* action reflects the way the Ministries and agencies are organized and makes it easier to identify the agency to carry out the recommended actions. The *location-specific* action focuses particularly on acute environmental problems at local levels that need to be addressed on a priority basis. The *long-term* actions include environmental degradation to such degree that might become even more serious and threatening, if cognizance is not taken immediately.

### 2.2.3 *National Conservation Strategy, 1992*

The National Conservation Strategy, 1992 provides recommendations for sustainable development of the industrial sector. The key aspects of the strategy are as follows:

- All industries shall be subject to an EIA and the adoption of pollution prevention/control technologies shall be enforced;
- Hazardous or toxic materials/wastes shall not be imported as raw materials for industry;
- Import of appropriate and environmentally-sound technology shall be ensured; and
- Dependence on imported technology and machinery should gradually be reduced in favour of sustainable local skills and resources.

### 2.2.4 *Other Policies relevant to Environment*

Additional Bangladesh policies, their key features and applicability to the subject Project are detailed in *Table 2.1*.

**Table 2.1** *Policies relevant to Environment*

<b>Policy</b>	<b>Key Features</b>	<b>Applicability</b>
The National Forest Policy, 1994	<ul style="list-style-type: none"> <li>• Afforestation of 20% land</li> <li>• Bio-diversity of the existing degraded forests</li> <li>• Strengthening of the agricultural sector</li> <li>• Control of Global warming, desertification</li> <li>• Control of trade in wild birds and animals</li> <li>• Prevention of illegal occupation of the forested land, tree felling and hunting of wild animals</li> </ul>	Not applicable, as no diversion of forest land is involved in the Project.
National Land Transport Policy, 2004	<ul style="list-style-type: none"> <li>• All new roads and major improvements will be subjected to an EIA</li> <li>• Funding will be provided for mitigation measures</li> <li>• The Government will publish environmental standards for new roads and new design standards addressing environmental issues</li> </ul>	Not applicable, as no new road construction is involved in the Project. Only an approach road along the boundary of BPDB Plant will be constructed for site access.
The National Water Policy, 1999	<ul style="list-style-type: none"> <li>• Protection, restoration and enhancement of water resources</li> <li>• Protection of water quality, including strengthening regulations concerning agrochemicals and industrial effluent</li> <li>• Sanitation and potable water</li> <li>• Fish and fisheries</li> <li>• Participation of local communities in all water sector development</li> </ul>	<p>Applicable for the preservation of water quality.</p> <p>Applicable, as water for cooling and other purposes is to be drawn from the Dehular Khal with discharge of treated water after treatment to same waterbody. Dehular Khal will also be used for transportation of construction material, heavy</p>

Policy	Key Features	Applicability
		equipment and machinery during construction phase and liquid fuel (HSD) during operation phase.
National Landuse Policy, 2001	<ul style="list-style-type: none"> <li>Deals with several land uses including: agriculture (crop production, fishery and livestock), housing, forestry, industrialization, railways and roads, tea and rubber</li> <li>Identifies land use constraints in all these sectors</li> </ul>	Applicable, as landuse of the Project site is industrial and owned by BPDB; however, a small patch of land about 5.78 acres will be required to be converted to industrial use, which is currently used for agriculture.
Draft Wetland Policy, 1998	<ul style="list-style-type: none"> <li>Establishment of principles for the sustainable use of wetland resources</li> <li>Maintenance of the existing level of biological diversity</li> <li>Maintenance of the functions and values of wetlands</li> <li>Promotion and recognition of the value of wetland functions in resource management and economic development</li> </ul>	Not directly applicable, however may be applicable once the draft policy is finalised
National Fisheries Policy, 1998	<ul style="list-style-type: none"> <li>Preservation, management and exploitation of fisheries resources in inland open water</li> <li>Fish cultivation and management in inland closed water.</li> <li>Prawn and fish cultivation in coastal areas</li> <li>Preservation, management and exploitation of sea fishery resources</li> </ul>	Applicable as water for cooling and other purposes is to be drawn from the Dehular Khal with discharge of treated water after treatment to same waterbody. Dehular Khal will also be used for transportation of construction material, heavy equipment and machinery during construction phase and liquid fuel (HSD) during operation phase.
The Energy Policy, 1996	<ul style="list-style-type: none"> <li>Provides for utilization of energy for sustainable economic growth, supply to different zones of the country, development of the indigenous energy source and environmentally sound sustainable energy development programmes</li> <li>Highlights the importance of EIA's for any new energy development project</li> </ul>	Applicable as subject Project is a Power Plant
The Power Policy, 1995	<ul style="list-style-type: none"> <li>Is an integral part of the Energy Policy and deals with policy statement on demand forecast, long term planning and project implementation, investment terms, fuels and technologies, load management, institutional issues, private sector participation, technology transfer and research programme, environmental policy and legal issues</li> </ul>	Applicable as subject Project is a Power Plant
Industrial Policy, 1999	<ul style="list-style-type: none"> <li>Deals with industrial development, direct foreign investments, investment by public and private sector, introduction of new appropriate technology, women's participation, infrastructure development</li> </ul>	Applicable as the Project is an industrial development and foreign investments.



Policy	Key Features	Applicability
	and environmentally sound industrial development	

### 2.3 *ENVIRONMENT AND SOCIAL RELATED LEGISLATIONS IN BANGLADESH*

The main Acts and Regulations guiding environmental protection and conservation in Bangladesh are outlined in the following subsections.

#### 2.3.1 *The Environment Conservation Act, 1995 (subsequent amendments in 2000, 2002 and 2010)*

The provisions of the Act authorize the Director General of Department of Environment (DOE) to undertake any activity that is deemed fit and necessary to conserve and enhance the quality of environment and to control, prevent and mitigate pollution. The main highlights of the act are:

- Declaration of Ecologically Critical Areas;
- Obtaining Environmental Clearance Certificate;
- Regulation with respect to vehicles emitting smoke harmful for the environment;
- Regulation of development activities from environmental perspective;
- Promulgation of standards for quality of air, water, noise, and soils for different areas and for different purposes;
- Promulgation of acceptable limits for discharging and emitting waste;
- Formulation of environmental guidelines relating to control and mitigation of environmental pollution, conservation and improvement of environment;
- Clarification of defining wetlands and Ecologically Critical Areas as well and included many important environmental concerns such as conservation wetlands, hill cutting, ship breaking, and hazardous waste disposal.
- Affected persons given provision for putting objections or taking legal actions against the polluters or any entity creating nuisance for affected person.

#### 2.3.2 *Environment Conservation Rules (ECR), 1997 (subsequent amendments in 2002, 2003 and 2010)*

The Environment Conservation Rules, 1997 are the first set of rules promulgated under the Environment Conservation Act, 1995. These Rules provide for, inter alia, the following:

- The National Environmental Quality Standards (EQS) for ambient air, surface water, groundwater, drinking water, industrial effluents, emissions, noise and vehicular exhaust;
- Categorization of industries, development projects and other activities on the basis of actual (for existing industries/development projects/activities)

and anticipated (for proposed industries/development projects/activities) pollution load;

- Procedure for obtaining environmental clearance;
- Requirements for undertaking IEE and EIA's as well as formulating EMP's according to categories of industries/development projects/activities; and
- Procedure for damage-claim by persons affected or likely to be affected due to polluting activities or activities causing hindrance to normal civic life.

Depending upon the location, size and severity of pollution loads, projects/activities have been classified in ECR, 1997 into four categories: *Green, Orange A, Orange B* and *Red* respectively as nil, minor, medium and severe impacts on important environmental components (IECs).

### 2.3.3 *Water Act, 2013*

The Act declares all form of water within the territory of Bangladesh as the property of the government. The Act requires permit/license for withdrawing large scale of surface or groundwater. Prevention of transboundary water pollution is also discoursed in the act. In this regard, combined survey, study and research on the international rivers and activities to prevent chemical and biological pollutant are suggested.

According to this act, for regulating and controlling water pollution, the provisions of Bangladesh Environment Conservation Act, 1995 and ECR (1997) would be applicable. As the proposed project will be using water from Dehular Khal for meeting the water demand and also treated water will be discharged into same waterbody, hence this act is applicable.

### 2.3.4 *Acquisition and Requisition of Immovable Property Ordinance, 1982*

The basic principles behind compensation of property in Bangladesh are founded in Articles 42 and 47 of the Constitution (1972). The current legislation for governing land acquisition in Bangladesh is the "Acquisition and Requisition of Immovable Property Ordinance (ARIPO), 1982 and amended in 1983, 1993 and 1994. Key features of the ordinance are as follows:

- This Ordinance provides the Deputy Commissioner (DC) with the power to initiate the acquisition of any property in any locality within his district that is likely to be needed for a public purpose or in the public interest.
- It describes the entire procedure of notice and intimations prior to acquisition of any property and process and timeframes for raising objections.
- Section 8 deals with matters to be considered in determining compensation which is based on the market value of the property at the date of publication of the notice under section 3.
- It defines the role and authority of Divisional Commissioner in decision making, compensation issues and in case of dispute. Among the matters to be considered in determining compensation are the following:

- The damage that may be sustained by the person interested, by reason of the taking of standing crops or trees which may be on the property at the time of taking possession thereof by the Deputy Commissioner,
- The damage that may be sustained by reason of the acquisition injuriously affecting his other properties, movable or immovable, in any other matter, or his earnings; and
- If in consequence of the acquisition of the property, the person interested is likely to be compelled to change his residence or place of business, the reasonable expenses, if any, incidental to such change; In terms of compensation, the Ordinance explicitly states that the DC, when determining compensation, shall neither consider any disinclination of the person to part with the property, nor any increase in the value of the property to be acquired likely to accrue from the use of it after it has been acquired.
- The Ordinance also covers the case of temporary acquisition of property for a public purpose or in the public interest.

Section 7(1) (b) makes provision for apportionment of the compensation among all the persons interested in the property. Further, Section 10A makes specific provision for payment of compensation to bargadar (*share cultivators*).

Section-18 deals with requisition of property which is required for temporarily for a public purpose. Section 20 deals with the award of the compensation for requisition of the property under Section 18. The amount of compensation payable for the requisition of any property consist of a recurring payment in respect of the period of requisition (equal to rent of lease that would be revised in every two years) and other associated damages such as expenses on account of vacating, expenses on account of re-occupying the property, and damages other than wear and tear, caused to the property during the period of requisition. Section 23 makes provision for protection of the property to prevent deterioration and to ensure proper maintenance of the requisitioned property.

### 2.3.5 *Administrative and Regulatory Guidelines and Instructions*

In addition to the provisions in the law, the land acquisition process is regulated by certain administrative instructions and procedural requirements. The most important of these are summarised here.

- In 1976, the Government constituted land allocation committees at the district, divisional and central levels to control what was regarded as too lavish taking of land for public purposes. The committees were charged with ensuring 'the most rigid measures of economy in the use of land for purposes other than agriculture.'
- The District Land Allocation Committees (DLACs) are chaired by the DC and have seven other members. These members include Executive Engineers of the R&H Department and the Public Works Department, and

the Civil Surgeon. They are entrusted with land allocation within the district not exceeding two acres.

- The Divisional LACs are chaired by the Divisional Commissioner and have technical representation at the Superintending Engineer and Deputy Director level. These committees consider land acquisition cases involving between two and five acres of land. All cases of more than five acres go to the Central Land Allocation Committee (CLAC). This committee is chaired by the Minister of Land Administration and has technical representation at the Secretary level. In 1989, the Government ordered that in all cases involving the acquisition of land exceeding 10 bighas, the President would have to give consent.

### 2.3.6

#### *Other Relevant National Legal Instruments for the Project*

*Table 2.2* presents an outline of other National legal instruments that will have relevance to the proposed Project with respect to the social and environmental considerations.

**Table 2.2 National Legal Instruments relevant to the Project**

Act/ Rule/ Law/ Ordinance	Enforcement Agency – Ministry/ Authority	Key Features	Applicability to proposed Project
The Environment Conservation Act, 1995 and subsequent amendments in 2000, 2002 and 2010	Department of Environment Ministry of Environment and Forests,	<ul style="list-style-type: none"> <li>• Define Applicability of environmental clearance</li> <li>• Regulation of development activities from environmental perspective</li> <li>• Framing applicable limits for emissions and effluents</li> <li>• Framing of standards for air, water and noise quality</li> <li>• Formulation of guidelines relating to control and mitigation of environmental pollution, conservation and improvement of environment</li> <li>• Declaration of Ecologically critical areas</li> </ul>	Applicable
Environmental Conservation Rules, 1997 and subsequent amendments in 2002, 2003 and 2010	Department of Environment Ministry of Environment and Forests	<ul style="list-style-type: none"> <li>• Declaration of Ecologically critical areas</li> <li>• Requirement of environmental clearance certificate for various categories of projects</li> <li>• Requirement of IEE/EIA as per category</li> <li>• Renewal of the environmental clearance certificate within 30 days after the expiry</li> <li>• Provides standards for quality of air, water and sound and acceptable limits for emissions/ discharges from vehicles and other sources</li> </ul>	Applicable Projects falls under Red Category and require EIA approval prior to start of construction activities and environmental clearance prior to start of operation.
Environment Court Act, 200 and amedments 2010	Ministry of Environment and Forests and Judiciary	<ul style="list-style-type: none"> <li>• GOB has given highest priority to environment pollution</li> <li>• Passed 'Environment Court Act, 2000 for completing environment related legal proceedings effectively.</li> <li>• provides the jurisdictions of environment court, penalty for violating court's order, trial procedure in special magistrate's court, power of entry and search, procedure for investigation, procedure and power of environment court, authority of environment court to inspect, appeal procedure and formation of environment appeal court.</li> </ul>	Applicable for completing environmental legal requirements effectively
The Vehicle Act, 1927; The Motor Vehicles Ordinance, 1983; and The Bengal Motor Vehicle Rules, 1940	Bangladesh Road Transport Authority	<ul style="list-style-type: none"> <li>• Exhaust emissions</li> <li>• Vehicular air and noise pollution</li> <li>• Road/traffic safety</li> <li>• Vehicle Licensing and Registration</li> <li>• Fitness of Motor Vehicles</li> <li>• Parking by-laws.</li> </ul>	Applicable for proposed Project in relation to road transport.
The Removal of Wrecks and Obstructions in inland	Bangladesh Water Transport Authority	<ul style="list-style-type: none"> <li>• Removal of wrecks and obstructions in inland navigable waterways</li> </ul>	Applicable as Dehular Khal- inland navigable

Act/ Rule/ Law/ Ordinance	Enforcement Agency - Ministry/ Authority	Key Features	Applicability to proposed Project
Navigable Water Ways Rules 1973			waterway will be used for material and machinery transport for the Project
Water Supply and Sanitation Act, 1996	Ministry of Local Government, Rural Development and Cooperatives	<ul style="list-style-type: none"> <li>• Management and Control of water supply and sanitation in urban areas.</li> </ul>	Not directly applicable, however, indirectly applicable when considering water usage management and sanitation facilities for the project
The Ground Water Management Ordinance, 1985	Upazilla Parishad	<ul style="list-style-type: none"> <li>• Management of ground water resources</li> <li>• Installation of tube-wells at any place after license from Upazilla Parishad only</li> </ul>	Proposed Project will use surface water source however, should groundwater also be required then licenses will need to be obtained prior to installation of any tube-wells, and ground seepage
The Water Act, 2012	National Water Council	<ul style="list-style-type: none"> <li>• Permit/license requirement for withdrawing large scale of surface or groundwater.Prevention of transboundary water pollution</li> <li>• Combined survey, study and research on the international rivers and activities to prevent chemical and biological pollutant are suggested.</li> <li>• For regulating and controlling water pollution, the provisions of Bangladesh Environment Conservation Act, 1995 and ECR (1997) would be applicable</li> </ul>	Applicable, as the water requirement will be met from Dehular Khal and treated water will be discharged into the same.
The Forest Act, 1927 and subsequent amendments in 1982 and 1989	Ministry of Environment and Forests	<ul style="list-style-type: none"> <li>• Categorization of forests as reserve, protected and village forests</li> <li>• Permission is required for use of forest land for any non-forest purposes</li> </ul>	Not applicable as proposed Project is not on forest land
The Private Forests Ordinance Act, 1959	Regional Forest Officer, Forest Department	<ul style="list-style-type: none"> <li>• Conservation of private forests and for the afforestation on wastelands</li> </ul>	Not applicable as proposed Project is not affecting plantations on private/ government land.

Act/ Rule/ Law/ Ordinance	Enforcement Agency - Ministry/ Authority	Key Features	Applicability to proposed Project
Bangladesh Wild Life (Preservation) Act, 1974	Ministry of Environment and Forest; Bangladesh Wild Life Advisory Board	<ul style="list-style-type: none"> <li>• Preservation of Wildlife Sanctuaries, Parks, and Reserves</li> </ul>	Not applicable as the Project AOI does not have any wildlife areas
Wildlife (Conservation and Security ) Act, 2012	Ministry of Environment and Forests, Bangladesh Wildlife Advisory Board	<ul style="list-style-type: none"> <li>• An act to provide for the conservation and safety of biodiversity, forest and wildlife of the country by repealing the existing law relating to conservation and management of wildlife of Bangladesh.</li> </ul>	Not applicable as the Project study area does not have any wildlife areas
National Biodiversity Strategy and Action Plan (2004)	Ministry of Environment and Forest Bangladesh Wild Life Advisory Board	<ul style="list-style-type: none"> <li>• Conserve, and restore the biodiversity of the country for well-being of the present and future generations</li> <li>• Maintain and improve environmental stability for ecosystems</li> <li>• Ensure preservation of the unique biological heritage of the nation for the benefit of the present and future generations</li> <li>• Guarantee the safe passage and conservation of globally endangered migratory species, especially birds and mammals in the country</li> <li>• Stop introduction of invasive alien species, genetically modified organisms and living modified organisms</li> </ul>	Applicable for conservation of bio-diversity
National Water Bodies Protection Act, 2000	Town development authority/Municipalities	<ul style="list-style-type: none"> <li>• The characterization of water bodies as rivers, canals, tanks or flood plains identified in the master plans formulated under the laws establishing municipalities in division and district towns shall not be changed without approval of concerned ministry</li> </ul>	Applicable due to the proximity to and use of surface water bodies
The Protection and Conservation of Fish Act 1950 subsequent amendments in 1982	Ministry of Fisheries and Livestock	<ul style="list-style-type: none"> <li>• Protection and conservation of fish in Government owned water bodies</li> </ul>	Applicable for the conservation of fish as the intake and outfall points will be the Dehular Khal
The Embankment and Drainage Act 1952	Ministry of Water Resources	<ul style="list-style-type: none"> <li>• An Act to consolidate the laws relating to embankment and drainage and to make better provision for the construction, maintenance, management, removal and control of embankments and water courses for the better drainage of lands and for their protection from floods, erosion and other damage by water</li> </ul>	Applicable due to the site location and to avoid flooding during monsoon season.
Antiquities Act, 1968	Ministry of Cultural Affairs	<ul style="list-style-type: none"> <li>• This legislation governs preservation of the national cultural heritage, protects and controls ancient monuments, regulates antiquities as well as the maintenance, conservation and</li> </ul>	Not applicable as the study area reportedly does not have any likely

Act/ Rule/ Law/ Ordinance	Enforcement Agency - Ministry/ Authority	Key Features	Applicability to proposed Project
		restoration of protected sites and monuments, controls planning, exploration and excavation of archaeological sites	cultural heritage or ancient monuments of national or international significance. However in case, any such evidence of archaeological findings arise, the Project will need to act in conformance to the Act
The Acquisition and Requisition of Immovable Property Ordinance 1982 and subsequent amendments in 1994, 1995 and 2004	Ministry of Land	<ul style="list-style-type: none"> <li>Current GOB Act and Guidelines, relating to acquisition and requisition of land</li> </ul>	Applicable
Administrative and Regulatory Guidelines and Instructions for Land Acquisition	Ministry of Land	<ul style="list-style-type: none"> <li>Regulation of land acquisition process by certain administrative instructions and procedural requirements</li> </ul>	Applicable
Framework for Leasing of Government (Khas) Agricultural Land	Ministry of Land	<ul style="list-style-type: none"> <li>The rules for allotting and leasing Government-owned (khas) land to land less families</li> </ul>	Not directly applicable but indirectly if a family becomes landless in the process of acquisition
The Building Construction Act 1952 and subsequent amendments	Ministry of Works	<ul style="list-style-type: none"> <li>This act provide for prevention of haphazard construction of building and excavation of tanks which are likely to interfere with the planning of certain areas in Bangladesh</li> </ul>	Applicable
The Factories Act, 1965 and the Factories Rules 1979	Ministry of Labour	<ul style="list-style-type: none"> <li>This Act pertains to the occupational rights and safety of factory workers and the provision of a comfortable work environment and reasonable working conditions</li> </ul>	Applicable
Ozone Depleting Substances (Control) Rules, 2004	Ministry of Environment and Forests	<ul style="list-style-type: none"> <li>Ban on the use of Ozone depleting substances</li> <li>Phasing out of Ozone depleting substances</li> </ul>	Applicable
Noise Pollution (Control) Rules 2006	Ministry of Environment and Forests	<ul style="list-style-type: none"> <li>Prevention of Noise pollution</li> <li>Standards for noise levels</li> </ul>	Applicable
Hazardous Wastes and Ship Breaking Waste Management Rules, 2011	Ministry of Environment and Forests	<ul style="list-style-type: none"> <li>Safe handling, storage and disposal of hazardous waste</li> </ul>	Applicable
Bangladesh Labour Law 2006, Bangladesh Labour Act, 2013 and Bangladesh Labour Rules,	Ministry of Labour and Employment	<ul style="list-style-type: none"> <li>Provides health, safety and wellbeing of work force during project life cycle. In addition, it also stipulated that children under 18 years are not allowed to be employed during</li> </ul>	Applicable



Act/ Rule/ Law/ Ordinance	Enforcement Agency - Ministry/ Authority	Key Features	Applicability to proposed Project
2015		project life cycle and therefore, this law requires to be complied with	
Disaster Management Act, 2012	Ministry of Food and Disaster Managemen	<ul style="list-style-type: none"> <li>To make the activities about disaster management coordinated, object oriented and strengthened and to formulate rules to build up infrastructure of effective disaster management to fight all types of disaster</li> </ul>	Applicable, as the project is located in a cyclone prone area.
The Explosives Act, 1984 The Explosives Rules, 2004 The Gas Cylinders Rule, 1991 The Pressure Vessels Rules, 1995 The Natural Gas Rule, 1991 The Petroleum Act, 2016 The Petroleum Rules, 1937	Department of Explosives	<ul style="list-style-type: none"> <li>Use of explosive substances, gas cylinders, pressure vessels, petroleum product handling, storage</li> </ul>	Applicable
The Boiler Act, 1923 The Boiler Regulation, 1951 and amendment, 2007 The Boiler Attendant Rules, 2010	Office of the Chief Inspector of Boilers	<ul style="list-style-type: none"> <li>Law relating to boiler registration, inspection and certification</li> </ul>	Applicable
The Electricity Act, 1910 and Amendments and The Electricity Rules, 1937	Office of the Chief Electrical Inspector, Power Division	<ul style="list-style-type: none"> <li>Law relating to the supply and use of electrical energy</li> </ul>	Applicable

Source: Websites of DOE, Legislative and Parliamentary Affairs Division: Bangladesh Laws and Bangladesh Board of Investment: Business laws

The Ministry of Environment & Forest (MoEF) is responsible for overseeing all environmental matters relating to national environmental policy and regulatory issues in the country. The MoEF oversees the activities of the following technical/implementing agencies:

- Department of Environment (DOE);
- Forest Department (FD);
- Bangladesh Forest Industries Development Corporation (BFIDC);
- Bangladesh Forest Research Institute (BFRI); and
- Bangladesh National Herbarium (BNH).

#### *Other Related Organizations*

There are several other organisations under the administrative framework which would govern social and environmental functions related to the proposed Project, namely:

- Ministry of Land: Land reform and land acquisition directorate;
- Ministry of water resources: Bangladesh Water Development Board; and
- Local Government Engineering Department (LGED).

#### 2.4.2

#### *Department of Environment (DOE)*

The DOE has been placed under the MoEF as its technical wing and is statutorily responsible for the implementation of the *Environment Conservation Act, 1995*. The Department was created in 1989, to ensure sustainable development and to conserve and manage the environment of Bangladesh. The principal activities of the DOE are:

- Defining EIA procedures and issuing environmental clearance permits - the latter being the legal requirement before the proposed Project can be implemented;
- Providing advice or taking direct action to prevent degradation of the environment;
- Pollution control, including the monitoring of effluent sources and ensuring mitigation of environmental pollution;
- Setting the Quality Standards for environmental parameters;
- Declaring Ecologically Critical Areas (ECAs), where the ecosystem has been degraded to a critical state; and
- Review and evaluation of Initial Environmental Examinations (IEEs) and EIAs prepared for projects in Bangladesh.

#### *Environmental Clearance Process*

As mentioned in the *Section 3.3.2*, ECR has classified projects to be assessed by the DOE in four categories based on the severity of impacts on IECs:

- Green: Nil;
- Orange A: minor;

- Orange B: medium; and
- Red: severe.

The applicability of environmental clearance and the process in Bangladesh is described in *Figure 2.1*.

The EIA process consists of three stages, screening, IEE, and detailed EIA:

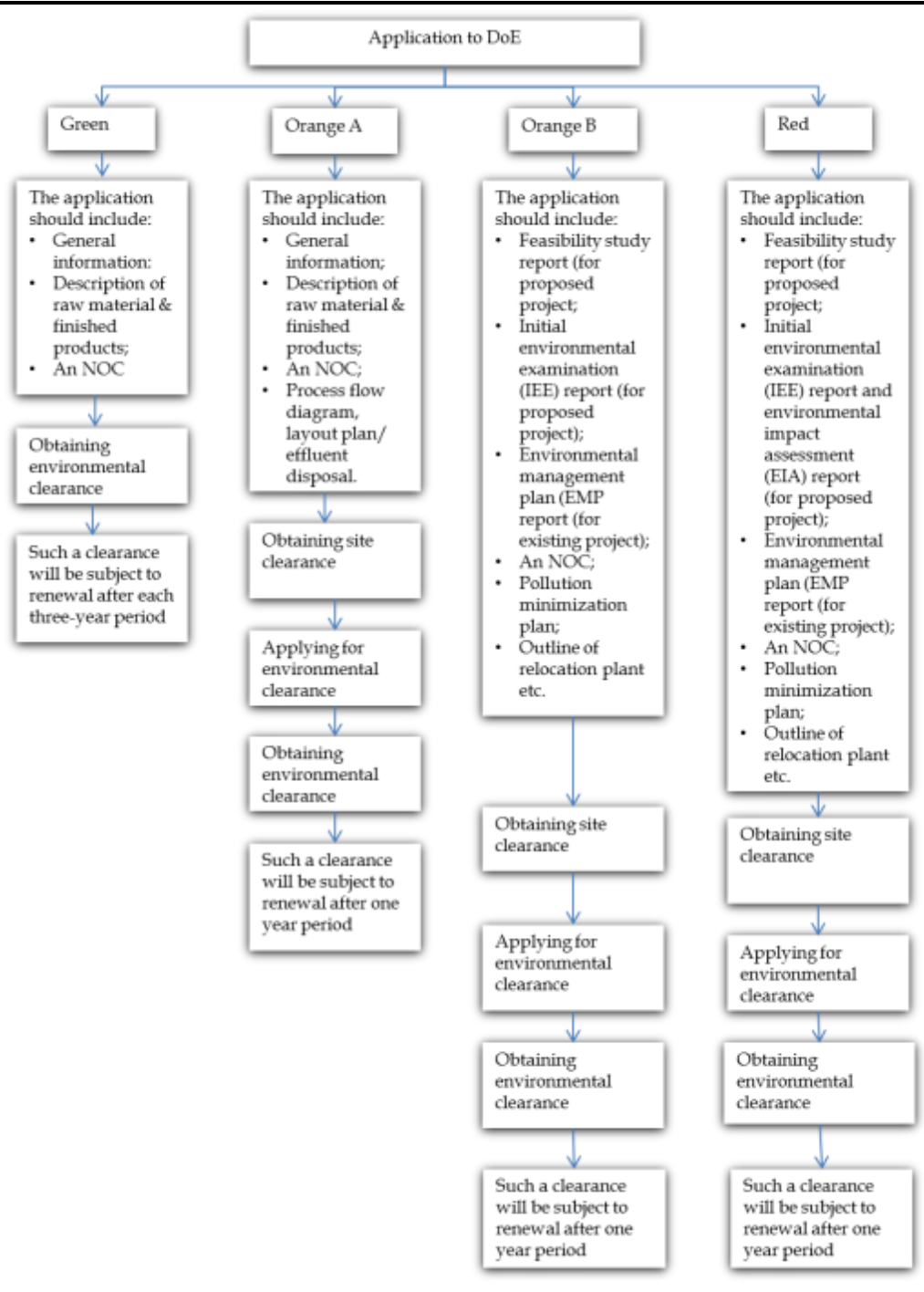
- Projects categorized as *Green* and *Orange-A* does not require IEE or EIA for environmental clearance however, the proponent must submit an application in a prescribed format along with specified documents;
- Projects categorized as *Orange-B* require an IEE to be submitted to the DOE along with an application in a prescribed format and other specified documents; and
- *Red* category projects require both IEE and EIA. An IEE is required for the location clearance and an EIA is required for the environmental clearance.

As per the *ECR 1997*, power plants and the *Subject Project fall under the Red category* as referred below:

- *Item 6:* power plants; and
- *Item 64:* construction/ replacement/ extension of natural gas/water/HSD pipelines.

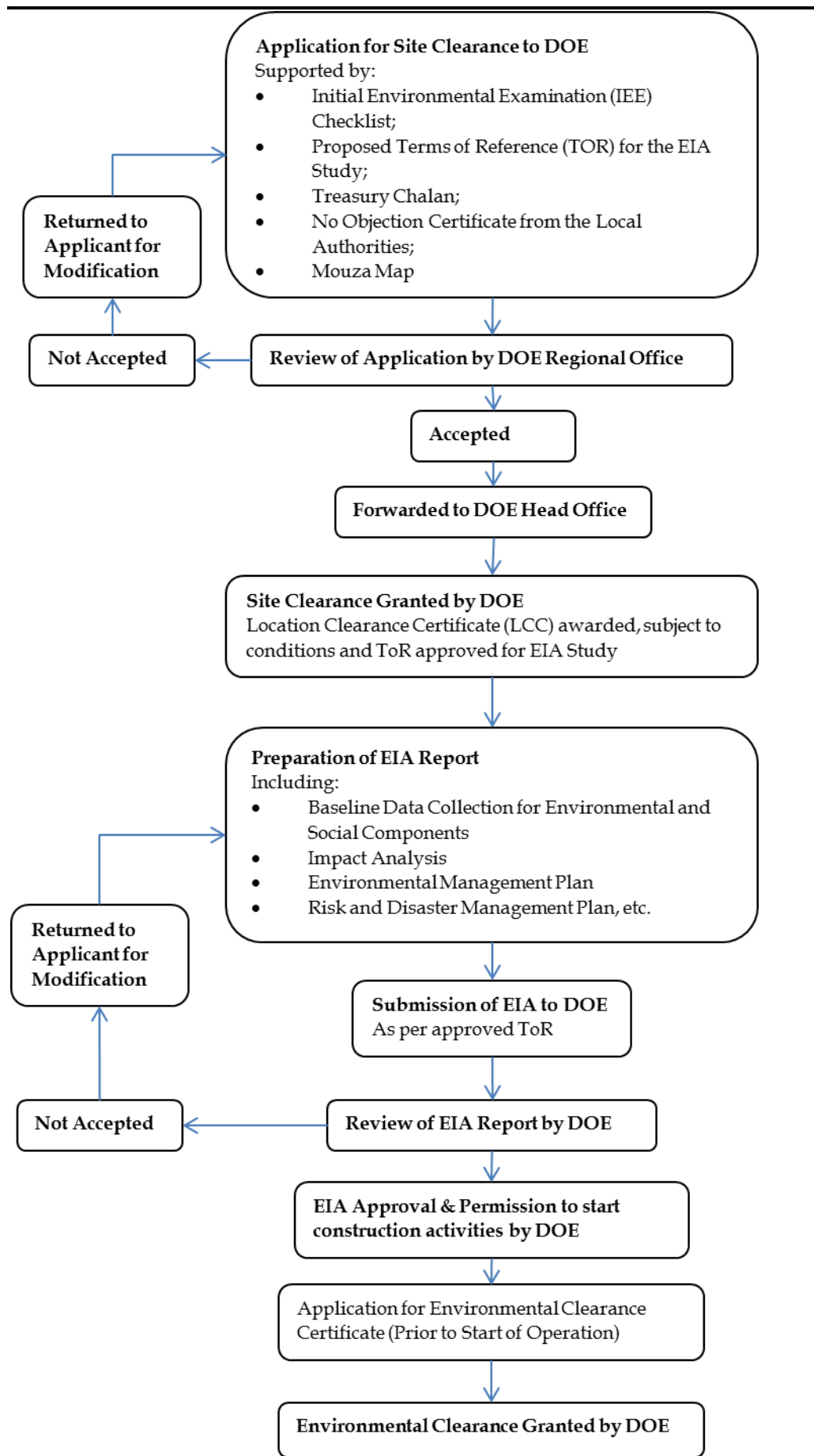
The process for obtaining an Environmental Clearance Certificate (ECC) for the proposed Project is outlined in *Figure 2.2*.

Figure 2.1 DOE Environmental Clearance Applicability and Procedure



Source: Adapted from DOE

Figure 2.2 Flow Chart of EIA Process Applicable to the Proposed Project



Source: Adapted from DOE

### 2.4.3 *Status of Project Approval from DOE*

The Project has already received ToR approval for conducting EIA study (refer to *Annex C*). The Project will apply for the site clearance after signing of land lease agreement (LLA) and procurement of additional land required for the Project. The EIA Report (this report); will be submitted to the DoE for EIA approval. This report will also be used for the potential lenders (as per the safeguard requirement of the potential lenders **Section 2.7**).

### 2.5 *INSTITUTIONAL ARRANGEMENTS RELATED TO LAND ACQUISITION IN BANGLADESH*

The administrative set up for land acquisition has two tiers under the Ministry of Land Administration. At the Division level, there is an Additional Commissioner dealing with land administration under the Commissioner. At the district level, there is an Additional Deputy Commissioner in charge of land administration. Under him, there is at least one Land Acquisition Officer and several Assistant Land Acquisition Officers. The number of officers depends on the size of the District. Non-gazetted officers in the land administration include Kanungos and surveyors.

The Deputy Commissioner allows 15 days to invite objections on the notice for land acquisition/requisition under section-3. If no objection is raised within the specified period, the Deputy Commissioner makes a decision within 10 days of the expiry of the notice period. If objections are received by Deputy Commissioner, then the records of the objection raised along with the inquiry made by him submits to the Divisional Commissioner if property does not exceed 50 standard bighas, and submits to the GOB, if the property exceeds 50 standard bighas. The decision of the Government or Divisional Commissioner as the case may be, is final provided the decision by Divisional Commissioner is made within 15 days and the decision made by the GOB is completed within 90 days. The decision by the Government or Divisional commissioner shall be conclusive evidence that the property is needed for a public interest.

The Deputy Commissioner serves the notice of acquisition of the property under section-6 requiring the all persons interested in the property to state the nature of their respective interests in the property and particulars of their claims to compensation for such interests not being earlier than fifteen days after the date of publication of the notice. After examining all the claims/statements received from all interested parties shall make an award stating the compensation and any apportionment of the said compensation. Deputy Commissioner shall give notice of his award to the persons interested and send the estimate of the award of compensation to the requiring person within 7 days from the date of making award of compensation.

Section 10 makes the payment of the compensation before taking the possession of the property. If the persons entitled do not consent to receive it, or any dispute over the apportionment then the amount of the compensation



is deposited in the Public Account of the Republic which is considered as deemed payment for the purpose of taking over possession.

Any person interested who has not accepted any award made by the Deputy Commissioner within 45 days of the service of the award, make an application to the arbitrator for revision of the award. Section-30 restricts the scope of the enquiry by the Arbitrator to a consideration of interests of the persons affected by the objection. Arbitrator shall be guided by the provisions of the sections 8, 9 or 20 provided that the compensation determined by the Arbitrator shall not exceed more than 10 per centum of the award of the Deputy Commissioner. An appeal shall lie to the Arbitration Appellate Tribunal against the award of the Arbitrator and the decision of the Arbitration Appellate Tribunal shall be final.

After the compensation for the property is paid or is deemed to be paid, Deputy Commissioner publishes a notice to that effect in official Gazette. The notice concludes the land acquisition procedure and vests the property absolutely in the government free from all encumbrances, and Deputy Collector takes the possession of the property.

The above process is likely to be in place for the proposed acquisition of right of way for the gas pipeline.

## 2.6 RELEVANT INTERNATIONAL TREATIES AND CONVENTIONS

Bangladesh is party to a number (30)<sup>1</sup> of international environmental conventions, treaties and agreements. The international treaties and conventions relevant to the Project and their status are detailed in *Table 2.3*.

**Table 2.3** *Project Relevant International Treaties and Conventions*

Environment related International convention and Treaties	Status	Applicability to Project
International Plant Protection Convention (Rome, 1951.)	01.09.78 (ratified)	Not applicable
International Convention for the Prevention of Pollution of the Sea by Oil (London, 1954 (as amended on 11 April 1962 and 21 October 1969.)	28.12.81 (entry into force)	Not applicable
Plant Protection Agreement for the South East Asia and Pacific Region (as amended) (Rome, 1956.)	04.12.74 (accessed) (entry into force)	Not applicable
International Convention Relating to Intervention on the High Seas in Cases of Oil Pollution Casualties (Brussels, 1969.)	04.02.82 (entry into force)	Not applicable

(1) <sup>1</sup> Department of Environment, Bangladesh

<b>Environment related International convention and Treaties</b>	<b>Status</b>	<b>Applicability to Project</b>
Convention on Wetlands of International Importance especially as Waterfowl Habitat (Ramsar, 1971) ("Ramsar Convention").	20.04.92 (ratified)	Not applicable as no Ramsar site in Project AOI
Convention Concerning the Protection of the World Cultural and natural Heritage (Paris, 1972.)	03.08.83 (accepted) 03.11.83 (ratified)	Not applicable as no such site in Project AOI
Convention on International Trade in Endangered Species of Wild Fauna and flora (Washington, 1973.) ("CITES Convention")	18.02.82 (ratified)	Applicable
United Nations Convention on the Law of the Sea (Montego Bay, 1982.)	10.12.82 (ratified)	Not applicable
Vienna Convention for the Protection of the Ozone Layer (Vienna, 1985.)	02.08.90 (accessed) 31.10.90 (entry into force)	Applicable
Montreal Protocol on Substances that Deplete the Ozone Layer (Montreal 1987.)	02.08.90 31.10.90 (accessed) (entry into force)	Applicable
London Amendment to the Montreal Protocol on substances that Deplete the Ozone Layer (London, 1990)	18.03.94 (accessed) 16.06.94 (entry into force)	Applicable
Copenhagen Amendment to the Montreal protocol on Substances that Deplete the Ozone Layer, Copenhagen, 1992	27.11.2000 (accepted) 26.2.2001 (entry into force)	Applicable
Montreal Amendment of the Montreal Protocol on Substances that Deplete the Ozone Layer, Montreal, 1997	27.7.2001 (Accepted) 26.10.2001 (Entry into force)	Applicable
Basel Convention on the Control of Transboundary Movements of Hazardous Wastes and Their Disposal (Basel, 1989.)	01.04.93 (accessed)	Applicable
International Convention on Oil Pollution Preparedness, Response and Cooperation (London, 1990.)	30.01.90 (signed) In the process of ratification	Not Applicable
United Nations Framework Convention on Climate Change, (New York, 1992.)	09.06.92 (signed) 15.04.94 (ratified)	Applicable
Convention on Biological Diversity, (Rio De Janeiro, 1992.)	05.06.92 (signed) 03.05.94 (ratified)	Applicable
International Convention to Combat Desertification, (Paris 1994.)	14.10.94 (signed) 26.01.1996 (ratification) 26.12.1996 (entry into force)	Not Applicable
Convention on the Prohibition of Military or Any Other Hostile Use of Environmental Modification Techniques, (Geneva, 1976.)	03.10.79 (accessed) (entry into force)	Not Applicable
Agreement Relating to the Implementation of	28.07.96 (signed)	Not Applicable

Environment related International convention and Treaties	Status	Applicability to Project
Part XI of the United Nations Convention on the Law of the Sea of 10 December 1982 (New York, 1994.)		
Convention on the Prohibition of the Development, Production, Stockpiling and Use of Chemical Weapons and on their Destruction (Paris, 1993.)	14.01.93 (signed)	Not Applicable
Convention on persistent Organic Pollutants, Stockholm	23.5.2001 (signed) 12.03.2007 (ratified)	Applicable and use of any persistent pollutants to be prohibited
Kyoto protocol to the United Nations Framework Convention on Climate Change	21.8.2001 (accessed)	Applicable

Source: DOE, Bangladesh

## 2.7

### INTERNATIONAL SAFEGUARD REQUIREMENTS

As mentioned in the RFP for the proposed Project, financing sources and financial support for the Project will be available from multi-lateral financial institutions, such as ADB, AIIB, EPFIs and IFC as well as from the export credit agencies of the countries where major pieces of equipment for the Project will be sourced. This support from multi-lateral financial institutions/ export credit agencies is also linked with adherence to international best practices and environmental and social safeguard requirements of the lenders. The following subsections outline the key environmental and social requirements of the ADB, the IFC, EPFIs and the AIIB, applicable to the Project.

### 2.7.1

#### IFC Performance Standards

The Performance Standards (PS) (January 2012) established by IFC stipulates that the Project shall meet certain requirements throughout the life cycle of an investment by IFC or other relevant financial institution such as other DFIs or commercial banks, which are signatory to the *Equator Principles, 2006*.

A brief description of the Performance standards is provided in *Table 2.4*.

**Table 2.4** IFC Performance Standards

Performance Standards	Specific Areas
Performance Standard 1:	Assessment and Management of Environmental and Social Risks and Impacts
Performance Standard 2	Labour and Working Conditions
Performance Standard 3	Resource Efficiency and Pollution Prevention
Performance Standard 4	Community Health, Safety and Security
Performance Standard 5	Land Acquisition and Involuntary Resettlement
Performance Standard 6	Biodiversity Conservation and Sustainable Management of Living Natural Resources
Performance Standard 7	Indigenous Peoples

Performance Standards	Specific Areas
Performance Standard 8	Cultural Heritage

*IFC Performance Standards, January 2012*

These PS and guidelines provide ways and means to identify impacts and affected stakeholders and lay down processes for management and mitigation of adverse impacts. A brief on the requirements as laid down in the performance standards is described in the following subsections.

Following sub-sections tries to provide the requirements of the specific PS, so as to set up the context for matching the requirements of these PS during the various stages of the life cycle of the Project.

*PS 1: Assessment and Management of Environmental and Social Risks and Impacts*

The PS 1 requires Social and Environmental Assessment and Management Systems for managing social and environmental performance throughout the life cycle of this Project and runs through all subsequent PSs. The main elements of PS 1 include:

- A Social and Environmental Assessment to understand the social and environmental impacts and risks;
- A Management Program for mitigating the impacts and minimizing the risks identified in the assessment;
- Establishing and ensuring organizational capacity and requisite trainings to the staff to implement the Management Programme;
- Identification and engagement with range of stakeholders that may be interested in their actions;
- Development and implementation of Stakeholder Engagement Plan that is scaled to the project risks and impacts and development stage and tailored to the characteristics and interests of the Affected Communities;
- Engagement and consultation with the affected communities, subject to identified risks and adverse impacts from a project;
- Informed Consultation and Participation (“ICP”) process for projects with potentially significant adverse impacts on affected communities;
- For projects with adverse impacts to Indigenous Peoples, requirement to engage them in a process of ICP and in certain circumstances requirement to obtain their Free, Prior, and Informed Consent (FPIC);
- Implementation and maintenance of procedure for external communications to receive and register external communications from the public, and their Redressal;
- Adequate monitoring and reporting systems to measure and report the effectiveness of the Management Programs.

The social and environmental performance is a continuous process to be initiated by the management and would involve communication between the organisation, its workers and local communities directly affected by the Project. The PS requires that Project proponent initiate regular assessment of

the potential social and environmental risks and impacts and consistently tries to mitigate and manage strategy on an ongoing basis.

### *PS 2: Labour and Working Conditions*

The economic growth through employment creation and income generation is recognised and balanced protecting the basic rights of workers. *PS 2* is guided by the various conventions of International Labour Organisation (ILO) and outlines the minimum requirements of working conditions, protection to the workforce (including issues of child and forced labour) and ensuring occupational health and safety of both its 'employees' as well as 'non employees' working through contractors. The PS requires:

- Establishment of a sound worker-management relationship;
- Encouraging equal opportunity and fair treatment of workers;  
Promoting compliance with national labour and employment laws;
- Management of accommodation services with provision of basic services;
- Promoting healthy and safe working conditions for workers. and
- Analysis of alternatives for retrenchment prior to implementing any collective dismissals.

*PS 2* requires project proponents to conduct its activities in a manner consistent with the four core labour standards (child labour, forced labour, non-discrimination, and freedom of association and collective bargaining). In addition, *PS 2* also addresses other areas such as working conditions and terms of employment, retrenchment, and occupational health and safety issues.

Some of these requirements refer to the applicable national law. Whereas national law establishes standards that are less stringent than those in *PS 2*, or are silent, the project proponent is expected to meet the requirements of *PS 2*.

### *PS 3: Resource Efficiency and Pollution Prevention*

*PS 3* outline a project level approach to resource efficiency and pollution prevention and control in line with internationally disseminated technologies and practices with objectives to:

- avoid or minimize adverse impacts on human health and the environment by avoiding or minimizing pollution from activities;
- promote more sustainable use of resources, including energy and water; and
- reduce project-related GHG emissions.

Key requirements of *PS3* are to consider ambient conditions and apply technically and financially feasible resource efficiency and pollution prevention principles and techniques that are best suited to avoid or where avoidance is not possible, minimize adverse impacts on human health and the environment during the entire project life-cycle. In addition, a project need to

follow good international industry practice (GIIP), as reflected in various internationally recognised sources including the World Bank Group Environmental, Health and Safety Guidelines.

*PS 4: Community, Health, Safety and Security*

*PS 4* concentrates on the responsibility that must be undertaken by the client to avoid or minimize the risks and impacts to the community's health, safety and security that may arise from project activities. *PS 4* requires a project to evaluate risks and impacts to the health and safety of the affected community during the Project life cycle and establish measures to avoid minimize and reduce risks and impacts from the Project.

A project needs to evaluate the risks and impacts to the health and safety of the Affected Communities during the project life-cycle and require establishing preventive and controlling measures consistent with GIIP, such as in the World Bank Group EHS Guidelines or other internationally recognized sources.

*PS 4* recognises that project activities, equipment, and infrastructure often bring benefits to communities including employment, ecosystem services, and opportunities for economic development. However, projects can also increase the potential for community exposure to risks and impacts arising from equipment accidents, structural failures, and releases of hazardous materials.

The performance standard details out project proponents responsibility to avoid or minimise the possible risks and impacts to community health, safety and security that may arise from project activities.

*PS 5: Land Acquisition and Involuntary Resettlement*

The objectives of this PS are to:

- avoid, and when avoidance is not possible, minimize displacement by exploring alternative project designs;
- avoid forced eviction;
- anticipate and avoid, or where avoidance is not possible, minimize adverse social and economic impacts from land acquisition or restrictions on land use by (i) providing compensation for loss of assets at replacement cost, and (ii) ensuring that resettlement activities are implemented with appropriate disclosure of information, consultation and the informed participation of those affected;
- improve, or restore, the livelihoods and standards of living of displaced persons;
- improve living conditions among physically displaced persons through the provision of adequate housing with security of tenure at resettlement sites.

PS 5 require a project to consider various processes and systems to avoid /minimise social and economic impacts related to land acquisition and resettlement.

This PS applies to physical or economic displacement resulting from the following types of land transactions:

- Land rights or land use rights acquired through expropriation or other compulsory procedures in accordance with the legal system of the host country;
- Land rights or land use rights acquired through negotiated settlements with property owners or those with legal rights to the land if failure to reach settlement would have resulted in expropriation or other compulsory procedures;
- Project situations where involuntary restrictions on land use and access to natural resources cause a community or groups within a community to lose access to resource usage where they have traditional or recognizable usage rights;
- Certain project situations requiring evictions of people occupying land without formal, traditional, or recognizable usage rights;<sup>8</sup> or
- Restriction on access to land or use of other resources including communal property and natural resources such as marine and aquatic resources, timber and non-timber forest products, freshwater, medicinal plants, hunting and gathering grounds and grazing and cropping areas.<sup>9</sup>

This PS does not apply to resettlement resulting from voluntary land transactions (i.e., market transactions in which the seller is not obliged to sell and the buyer cannot resort to expropriation or other compulsory procedures sanctioned by the legal system of the host country if negotiations fail). It also does not apply to impacts on livelihoods where the project is not changing the land use of the affected groups or communities.

*PS 6: Biodiversity Conservation and Sustainable Management of Living Natural Resources*

PS 6 aims at protecting and conserving biodiversity, maintaining ecosystem services, the variety of life in all its forms, including genetic, species and ecosystem diversity and its ability to change and evolve, is fundamental to sustainable development. The objectives of this PS are to:

- protect and conserve biodiversity;
- maintain the benefits from ecosystem services; and
- promote the sustainable management of living natural resources through the adoption of practices that integrate conservation needs and development priorities.

The components of biodiversity, as defined in the *Convention on Biological Diversity*, include ecosystems and habitats, species and communities, and genes and genomes, all of which have social, economic, cultural and scientific



importance. This PS addresses how clients can avoid or mitigate threats to biodiversity arising from their operations as well as incorporate sustainable management of renewable natural resources<sup>1</sup>.

PS 6 recognises that protecting and conserving biodiversity – the variety of life in all its forms, including genetic, species and ecosystem diversity – and its ability to change and evolve, is fundamental to sustainable development. It reflects the objectives of the *Convention on Biological Diversity* to conserve biological diversity and promote use of renewable natural resources in a sustainable manner.

For the purposes of implementation of this PS, habitats are divided into modified, natural and critical. Critical habitats are a subset of modified or natural habitats. For the protection and conservation of biodiversity, the mitigation hierarchy includes biodiversity offsets, which may be considered only after appropriate avoidance, minimization, and restoration measures have been applied. A biodiversity offset should be designed and implemented to achieve measurable conservation outcomes that can reasonably be expected to result in no net loss and preferably a net gain of biodiversity; however, a net gain is required in critical habitats. The design of a biodiversity offset must adhere to the “like-for-like or better” principle and must be carried out in

#### *PS 7: Indigenous Peoples*

PS 7 acknowledges the possibility of vulnerability of indigenous people<sup>2</sup> owing to their culture, beliefs, institutions and living standards, and that it may further get compromised by one or other project activity throughout the life cycle of the project. The PS underlines the requirement of avoiding / minimizing adverse impacts on indigenous people in a project area, respecting the local culture and customs, fostering good relationship and ensuring that development benefits are provided to improve their standard of living and livelihoods.

PS 7 recognises that Indigenous Peoples, as social groups with identities that are distinct from dominant groups in national societies, are often among the most marginalised and vulnerable segments of the population. The term “indigenous people” is more clearly defined in the IFC Guidance Note for PS 7.

<sup>1</sup> Given the complexity in predicting project impacts on biodiversity and ecosystem services over the long term, the client should adopt a practice of adaptive management in which the implementation of mitigation and management measures are responsive to changing conditions and the results of monitoring throughout the project’s lifecycle.

<sup>2</sup> There is no universally accepted definition of “Indigenous Peoples.” Indigenous Peoples may be referred to in different countries by such terms as “Indigenous ethnic minorities,” “aboriginals,” “hill tribes,” “minority nationalities,” “scheduled tribes,” “first nations,” or “tribal groups.” This Performance Standard applies to communities or groups of Indigenous Peoples who maintain a collective attachment, i.e., whose identity as a group or community is linked, to distinct habitats or ancestral territories and the natural resources therein. It may also apply to communities or groups that have lost collective attachment to distinct habitats or ancestral territories in the project area, occurring within the concerned group members’ lifetime, because of forced severance, conflict, government resettlement programs, dispossession of their lands, natural disasters, or incorporation of such territories into an urban area.

Objectives of PS 7 underscore the need to:

- ensure that the development process fosters full respect for the human rights, dignity, aspirations, culture, and natural resource-based livelihoods of Indigenous Peoples;
- anticipate and avoid adverse impacts of projects on communities of Indigenous Peoples, or when avoidance is not possible, to minimize and/or compensate for such impacts;
- promote sustainable development benefits and opportunities for Indigenous Peoples in a culturally appropriate manner;
- establish and maintain an on-going relationship based on Informed Consultation and Participation (ICP) with the Indigenous Peoples affected by a project throughout the project's life-cycle;
- ensure the Free, Prior, and Informed Consent (FPIC) of the Affected Communities of Indigenous Peoples when the circumstances described in this Performance Standard are present; and
- respect and preserve the culture, knowledge, and practices of Indigenous Peoples.

This PS also defines the private sector responsibilities where Government is managing indigenous peoples issues and states that where the government has a defined role in the management of Indigenous Peoples issues in relation to the project, the client will collaborate with the responsible government agency, to the extent feasible and permitted by the agency, to achieve outcomes that are consistent with the objectives of this Performance Standard. In addition, where government capacity is limited, the client will play an active role during planning, implementation, and monitoring of activities to the extent permitted by the agency. In this process, the client may need to include: (i) the plan, implementation, and documentation of the process of ICP and engagement and FPIC where relevant; (ii) a description of the government-provided entitlements of affected Indigenous Peoples; (iii) the measures proposed to bridge any gaps between such entitlements, and the requirements of this Performance Standard; and (iv) the financial and implementation responsibilities of the government agency and/or the client.

#### *PS 8: Cultural Heritage*

PS 8 aims to protect the irreplaceable cultural heritage and to guide clients on protecting cultural heritage in the course of their business operations. In addition, the requirements of this PS on a project's use of cultural heritage are based in part on standards set by the *Convention on Biological Diversity*.

PS 8 recognises the importance of cultural heritage with an objective to:

- Protect cultural heritage from the adverse impacts of project activities and support its preservation; and
- Promote the equitable sharing of benefits from the use of cultural heritage in business activities.

The PS requires the project proponent to comply with relevant national law on the protection of cultural heritage, including national law implementing the host country's obligations under the *Convention Concerning the Protection of the World Cultural and Natural Heritage* and other relevant international law.

The requirements of this Performance Standard apply to cultural heritage regardless of whether or not it has been legally protected or previously disturbed. The requirements of this PS do not apply to cultural heritage of Indigenous Peoples; PS 7 describes those requirements.

## 2.7.2 *IFC Project Categorization*

As part of its review of a project's expected social and environmental impacts, IFC uses a system of social and environmental categorisation. This categorisation is used to reflect the size of impacts understood as a result of the client's social and environmental assessment and to specify IFC's institutional requirements. The IFC categories are:

- *Category A Projects*: Projects with potential significant adverse social or environmental impacts that are diverse, irreversible or unprecedented;
- *Category B Projects*: Projects with potential limited adverse social or environmental impacts that are few in number, generally site-specific, largely reversible and readily addressed through mitigation measures;
- *Category C Projects*: Projects with minimal or no adverse social or environmental impacts, including certain financial intermediary (FI) projects with minimal or no adverse risks;
- *Category FI Projects*: All FI projects excluding those that are Category C projects.

IFC therefore categorises project primarily according to the significance and nature of impacts. IFC defines the project's area of influence as the primary project site(s) and related facilities that the client (including its contractors) develops or controls; associated facilities that are not funded as part of the project (funding may be provided separately by a client or a third party including the government), and whose viability and existence depend exclusively on the project and whose goods or services are essential for the successful operation of a project; areas potentially impacted by cumulative impacts from further planned development of a project; and areas potentially affected by impacts from unplanned but predictable developments caused by the project that may occur later or at a different location. The area of influence does not include potential impacts that would occur without a project or independently of a project.

### 2.7.3 *IFC EHS Guidelines*

The *Environmental, Health, and Safety (EHS) General Guidelines*<sup>1</sup> (April 30, 2007) will be applicable for this Project. In addition to that, IFC's Sector specific *EHS Guidelines for Thermal Power Plants*<sup>2</sup> (December 19, 2008) will also apply.

### 2.7.4 *ADB's Safeguard Policy Statement, 2009*

In July 2009, ADB's Board of Directors approved the current Safeguard Policy Statement (SPS) governing the environmental and social safeguards of ADB's operations. The SPS builds upon ADB's previous safeguard policies on the Environment, Involuntary Resettlement, and Indigenous Peoples, and brings them into one consolidated policy framework with enhanced consistency and coherence, and more comprehensively addresses environmental and social impacts and risks. The SPS also provides a platform for participation by affected people and other stakeholders in the project design and implementation.

The SPS applies to all ADB-financed and/or ADB-administered projects and their components, regardless of the source of financing, including investment projects funded by a loan; and/or a grant; and/or other means, such as equity and/or guarantees. ADB works with borrowers and clients to put into practice the requirements of SPS.

The SPS supersedes ADB's Involuntary Resettlement Policy (1995), Policy on Indigenous Peoples (1998), and Environment Policy (2002). In accordance with the SPS, these previous policies apply to all projects and tranches of multi-tranche financing facility projects that were reviewed by ADB's management before 20 January 2010.

The objectives of ADB's safeguards are to:

- avoid adverse impacts of projects on the environment and affected people, where possible;
- minimize, mitigate, and/or compensate for adverse project impacts on the environment and affected people when avoidance is not possible; and
- assist borrowers and clients to strengthen their safeguard systems and develop the capacity to manage environmental and social risks.

ADB's SPS sets out the policy objectives, scope and triggers, and principles for three key safeguard areas:

(1) <sup>1</sup>

[http://www.ifc.org/ifcext/sustainability.nsf/AttachmentsByTitle/gui\\_EHSGuidelines2007\\_GeneralEHS/\\$FILE/Final+-+General+EHS+Guidelines.pdf](http://www.ifc.org/ifcext/sustainability.nsf/AttachmentsByTitle/gui_EHSGuidelines2007_GeneralEHS/$FILE/Final+-+General+EHS+Guidelines.pdf)

(2) <sup>2</sup>

[http://www1.ifc.org/wps/wcm/connect/dfb6a60048855a21852cd76a6515bb18/FINAL\\_Thermal%2BPower.pdf?MOD=AJPERES&id=1323162579734](http://www1.ifc.org/wps/wcm/connect/dfb6a60048855a21852cd76a6515bb18/FINAL_Thermal%2BPower.pdf?MOD=AJPERES&id=1323162579734)

- Environmental safeguards;
- Involuntary Resettlement safeguards; and
- Indigenous Peoples safeguards.

To help borrowers and clients and their projects achieve the desired outcomes, ADB adopts a set of specific safeguard requirements that borrowers and clients are required to meet in addressing environmental and social impacts and risks. These safeguard requirements are as follows:

- Safeguard Requirements 1: Environment (Appendix 1 of SPS);
- Safeguard Requirements 2: Involuntary Resettlement (Appendix 2 of SPS);
- Safeguard Requirements 3: Indigenous Peoples (Appendix 3 of SPS); and
- Safeguard Requirements 4: Special Requirements for Different Finance Modalities (Appendix 4 of SPS).

In addition, ADB does not finance activities on the prohibited investment activities list (Appendix 5 of SPS). Furthermore, ADB does not finance projects that do not comply with its safeguard policy statement, nor does it finance projects that do not comply with the host country's social and environmental laws and regulations, including those laws implementing host country obligations under international law.

*Consultation and Disclosure requirements of ADB*

ADB's *Safeguard Policy and Public Communications Policy (2011)* sets out disclosure requirements for various ADB activities, including safeguard requirement. Safeguard Requirements 2: Involuntary Resettlement (Appendix 2 of SPS); and Safeguard Requirements 3: Indigenous Peoples (Appendix 3 of SPS) sets out the need for meaningful consultation and information disclosure during project preparation and operation to the affected peoples and other stakeholders. Key requirements include:

- **Information Disclosure:** The borrower/client will submit the following documents to ADB for disclosure on ADB's website as per the applicability with respect to the Project:
  - Draft EIA including draft EMP;
  - Final EIA/IEE;
  - Updated EIA/IEE and corrective active plan;
  - Environmental Monitoring Reports.
  - Resettlement Plan (RP)/Resettlement Framework (RF)
  - Indigenous Peoples Plan (IPP)/Indigenous Peoples Planning Framework (IPPF)
  - Monitoring reports
- **Information disclosure to affected people or stakeholders:** The borrower/client will provide relevant environmental information in a timely manner, in an accessible place and in a form and language(s) understandable to affected people and other stakeholders. For illiterate people, other suitable communication methods will be used.

- **Consultation and Participation:** The borrower/client will carry out meaningful consultation with affected people and other concerned stakeholders, including civil society, and facilitate their informed participation.
- **Timing and Frequency for consultation and participation:** Meaningful consultation begins early in the project preparation stage and is carried out on an ongoing basis throughout the project cycle.

## 2.7.5

### *ADB Project Categorisation*

The SPS, 2009 further outlines a classification system for the categorization of projects. The classification tentatively occurs at the project identification stage, during the initial screening of anticipated impacts. However, classification is an on-going process, and the classification can be changed at any time with the concurrence of the Chief Compliance Officer (CCO), as more detailed information becomes available and a project proceeds.

#### *Environment*

A project's environment category is determined by the category of its most environmentally sensitive component, including direct, indirect, induced, and cumulative impacts. Each proposed project is scrutinized as to its type, location, scale, sensitivity and the magnitude of its potential environmental impacts. The level of detail and comprehensiveness of the EIA or IEE are commensurate with the significance of the potential impacts and risks.

A proposed project is assigned to one of the following categories depending on the significance of the potential environmental impacts and risks:

- *Category A:* A proposed project is classified as category A if it is likely to have significant adverse environmental impacts that are irreversible, diverse, or unprecedented. These impacts may affect an area larger than the sites or facilities subject to physical works. An EIA, including an environmental management plan (EMP), is required;
- *Category B:* A proposed project is classified as category B if its potential adverse environmental impacts are less adverse than those of category A projects. These impacts are site-specific, few if any of them are irreversible, and in most cases mitigation measures can be designed more readily than for category 'A' projects. An IEE, including an EMP, is required;
- *Category C:* A proposed project is classified as category C if it is likely to have minimal or no adverse environmental impacts. An EIA or IEE is not required, although environmental implications need to be reviewed; and
- *Category FI:* A proposed project is classified as category FI if it involves the investment of ADB funds to, or through, a financial intermediary.

#### *Involuntary Resettlement*

A project's involuntary resettlement category is determined by the category of its most sensitive component in terms of involuntary resettlement impacts.

The involuntary resettlement impacts of an ADB-supported project are considered significant if 200 or more persons will experience major impacts, which are defined as (i) being physically displaced from housing, or (ii) losing 10% or more of their productive assets (income generating). The level of detail and comprehensiveness of the resettlement plan are commensurate with the significance of the potential impacts and risks. A proposed project is assigned to one of the following categories depending on the significance of the probable involuntary resettlement impacts:

- *Category A:* A proposed project is classified as category A if it is likely to have significant involuntary resettlement impacts. A resettlement plan, including assessment of social impacts, is required;
- *Category B:* A proposed project is classified as category B if it includes involuntary resettlement impacts that are not deemed significant. A resettlement plan, including assessment of social impacts, is required;
- *Category C:* A proposed project is classified as category C if it has no involuntary resettlement impacts. No further action is required; and
- *Category FI:* A proposed project is classified as category FI if it involves the investment of ADB funds to, or through, a financial intermediary.

### *Indigenous Peoples*

ADB screens all projects to determine whether or not they have potential impacts on Indigenous Peoples<sup>1</sup>. For projects with impacts on Indigenous Peoples, an Indigenous Peoples Plan needs to be prepared. The degree of impacts is determined by evaluating (i) the magnitude of the impact on Indigenous Peoples' customary rights of use and access to land and natural resources; socio-economic status; cultural and communal integrity; health, education, livelihood systems, and social security status; or indigenous knowledge; and (ii) the vulnerability of the affected Indigenous Peoples.

Indigenous people's or ethnic minorities' issues are likely to be significant when it is established that groups in the project area have one or more of the following attributes: (i) self-identification or identification by others as a

<sup>1</sup> As per the working definition of indigenous peoples by ADB, two significant characteristics of indigenous peoples would be:

- descent from population groups present in a given area, most often before modern states or territories were created and before modern borders were defined; and
- Maintenance of cultural and social identities; and social, economic, cultural, and political institutions separate from mainstream or dominant societies and cultures. In some cases, over recent centuries, tribal groups or cultural minorities have migrated into areas to which they are not indigenous, but have established a presence and continue to maintain a definite and separate social and cultural identity and related social institutions. In such cases, the second identifying characteristic would carry greater weight.

Additional characteristics often ascribed to indigenous peoples include

- self-identification and identification by others as being part of a distinct indigenous cultural group, and the display of a desire to preserve that cultural identity;
- a linguistic identity different from that of the dominant society;
- social, cultural, economic, and political traditions and institutions distinct from the dominant culture;
- economic systems oriented more toward traditional systems of production than mainstream systems; and
- Unique ties and attachments to traditional habitats and ancestral territories and natural resources in these habitats and territories.

(Source: Policy on Indigenous Peoples, ADB)



distinct cultural group; (ii) a display of a desire to preserve such cultural identity; (iii) a linguistic identity distinct from that of the dominant society; (iv) distinct social, economic, and political traditions and institutions; (v) an economic system oriented more toward a traditional system of production; and (vi) a unique tie with and attachment to traditional habitat and ancestral territory and its natural resources; such groups are found to exhibit historical, socioeconomic, political, or demographic vulnerability; project intervention will be (positively or negatively) affecting one of these areas: customary rights to (ancestral) land and natural resources; their socioeconomic status; their health, education, livelihood, and social security status; indigenous people's knowledge; the project involves new construction, rehabilitation or expansion of large-scale infrastructure; or such interventions as water supply, sanitation, education, health, nutrition, or social protection target indigenous people; the project is located within or nearby the habitat of indigenous people; and/or project impacts are potentially long term, or irreversible or permanent, affecting a substantial portion of the indigenous community or the community as a whole.

A project is assigned to one of the following categories depending on the significance of the probable impact on the indigenous peoples:

Category	Impact	Actions Required
Category-A	Expected to have significant impact	Both IPP and SIA are required
Category-B	Expected to have limited impact	Both IPP and SIA are Required. A specific action favourable to indigenous peoples/ethnic minority is required and addressed through a specific provision in RRP and in related plans such as a resettlement action plan, a gender action plan, or a general community participatory plan.
Category-C	Not expected to have any impact on ethnic minority	No specific action required.

### 2.7.6 *Equator Principles, 2013*

The Equator Principles (2013) are a set of ten (10) voluntary standards adopted by financial institutions as a framework for environmental and social risk management for project finance transactions.

The subsequent table summarises the key EP requirements and their applicability for the proposed project:

**Table 2.5** *Equator Principles and their Applicability for the Project*

<b>Principles</b>	<b>Outline</b>	<b>Details</b>
Principle 1: Review and Categorization of the Project	Equator Principles Financial Institutions (EFPIs) are required to categorize projects based on the magnitude of its potential environmental and social risks based on the environmental and social screening criteria of IFC.	Projects are designated as Category A, B or C when it represents, respectively, a high, medium or low level of risk as per the following understanding:  <i>Category A</i> - Projects with potential significant adverse environmental and social risks and/or impacts that are diverse, irreversible or unprecedented; <i>Category B</i> - Projects with potential limited adverse environmental and social risks and/or impacts that are few in number, generally site-specific, largely reversible and readily addressed through mitigation measures; and <i>Category C</i> - Projects with minimal or no adverse environmental and social risks and/or impacts.
Principle 2: Environmental and Social Assessment	For projects categorized as A or B, the borrower has to conduct an ESA to appropriately address all social and environmental impacts and risks.	The assessment should also propose mitigation and management measures. The principle requires ESIA study to assess social and environmental impacts and risks due to the Category A project.
Principle 3: Applicable Environmental and Social Standards	For projects located in non-OECD countries, the assessment will refer to the applicable IFC Performance Standards and applicable industry specific EHS guidelines.	The assessment process should address compliance with the relevant host country laws, regulations, permits that pertain to social and environmental issues.
Principle 4: Environmental and Social Management System and Equator Principles Action Plan	For all Category A and Category B Projects, the borrower has to develop or maintain an Environmental and Social Management System (ESMS).	Further, an Environmental and Social Management Plan (ESMP) will be prepared by the borrower to address issues raised in the Assessment process and incorporate actions required to comply with the applicable standards. Where the applicable standards are not met to the EPFI's satisfaction, the borrower and the EPFI will agree an Equator Principles Action Plan (AP). The Equator Principles AP is intended to outline gaps and commitments to meet EPFI requirements in line with the applicable standards.
Principle 5: Stakeholder Engagement	For all Category A and Category B Projects, the EPFI will require the borrower to demonstrate effective Stakeholder Engagement as an ongoing process in a structured and culturally appropriate manner with Affected Communities and, where relevant, other stakeholders	For Projects with potentially significant adverse impacts on Affected Communities, the borrower will conduct an informed consultation and participation process. The borrower will tailor its consultation process to the risks and impacts of the Project; the Project's phase of development; the language preferences of the Affected Communities; their decision-making processes; and the needs of disadvantaged and vulnerable groups. This process should be free from external manipulation, interference, coercion and intimidation.
Principle 6: Grievance	For all Category A and where	The grievance mechanism is required to be scaled to the risks and impacts of the Project

Principles	Outline	Details
Mechanism	appropriate Category B Projects, the borrower will be required as part of the ESMS, to establish a grievance mechanism designed to receive and facilitate resolution of concerns and grievances about the Project's environmental and social performance.	and have Affected Communities as its primary user. It will seek to resolve concerns promptly, using an understandable and transparent consultative process that is culturally appropriate, readily accessible, at no cost, and without retribution to the party that originated the issue or concern. The mechanism should not impede access to judicial or administrative remedies. The mechanism will have to be informed to the affected Communities in the course of the Stakeholder Engagement process.
Principle 7: Independent Review	For all Category A and, as appropriate, Category B Projects, an Independent Environmental and Social Consultant, not directly associated with the client, will carry out an Independent Review of the Assessment Documentation including the ESMPs, the ESMS, and the Stakeholder Engagement process documentation in order to assist the EPFI's due diligence, and assess Equator Principles compliance.	The Independent Environmental and Social Consultant will also propose or opine on a suitable Equator Principles AP capable of bringing the Project into compliance with the Equator Principles, or indicate when compliance is not possible.
Principle 8: Covenants	It is important to incorporate covenants linked to compliance.	For all category A and B projects, the borrower will covenant in financing documentation a) to comply with all host country laws; b) to comply with Equator Principles; c) to provide periodic reports to the EPFIs and d) to de-commission the facilities in accordance with a decommissioning plan.
Principle 9: Independent Monitoring and Reporting	To ensure ongoing monitoring and reporting over the life of the loan.	The EPFI will, for all category A projects, and as appropriate category B projects, require an independent environmental and /or social expert, or require that the borrower retain qualified and experienced external experts to verify its monitoring information which would be shared with the EPFIs.
Principle 10: Reporting and Transparency	For all category A and category B projects as appropriate, the borrower will commit that at a minimum, a summary of the ESIA is accessible and available online.	The borrower will publicly report GHG emission levels during the operational phase for Projects emitting over 100,000 tonnes of CO <sub>2</sub> equivalent annually. The EPFI will report publicly, at least annually, on transactions that have reached Financial Close and on its Equator Principles implementation processes and experience, taking into account appropriate confidentiality considerations.

The Environmental and Social Framework (ESF) of the Asian Infrastructure Investment Bank (AIIB) was approved by the Board in February 2016, and sets forth in the Environmental and Social Policy (ESP) mandatory environmental and social requirements for each Project funded by the Bank to achieve outcomes consistent with its mandate to support infrastructure development and enhance interconnectivity in Asia. The Bank has also established an Environmental and Social Exclusion List and will not knowingly finance projects involving activities included on this list.

As part of its vision provided in the ESF, AIIB has established the following:

- The Bank requires the integration of environmental and social sustainability in the identification, preparation and implementation of the Project, which in turns become part of its decision-making process.
- The Bank requires meaningful consultation of Stakeholders by its Clients throughout the Project life-cycle.
- The Bank supports its Clients to identify potential gender-specific opportunities as well as gender-specific adverse risks and impacts under their Projects and to develop mitigation measures to avoid or reduce such impacts and risks.
- The Bank recognizes the important role played by workers and their representatives in the development process and their contribution to sustainable economic growth, thus requires protection to be afforded to workers on their rights and working conditions, and avoidance of forced, harmful or exploitative forms of labor.
- The Bank recognizes that protecting and conserving biodiversity, sustainably managing terrestrial and aquatic natural resources and maintaining core ecological functions and services are fundamental to sustainable development.

The ESP sets out the general processes and requirements for Project screening and categorization, environmental and social due diligence, environmental and social assessment, environmental and social management plans, environmental and social assessment tools and management planning frameworks, information disclosure, consultation, monitoring and reporting, as well as grievance redress. It also defines the roles and responsibilities between AIIB and its Clients, and must be complied with to secure AIIB financing.

The Bank requires each proposed Project to be assigned one of the following four categories:

- **Category A.** A Project is categorized A if it is likely to have significant adverse environmental and social impacts that are irreversible, cumulative, diverse or unprecedented. These impacts may affect an area larger than the sites or facilities subject to physical works and may be temporary or permanent in nature.
- **Category B.** A Project is categorized B when: it has a limited number of potentially adverse environmental and social impacts; the impacts are

not unprecedented; few if any of them are irreversible or cumulative; they are limited to the Project area; and can be successfully managed using good practice in an operational setting.

- **Category C.** A Project is categorized C when it is likely to have minimal or no adverse environmental and social impacts.
- **Category FI.** A Project is categorized FI if the financing structure involves the provision of funds to or through a financial intermediary (FI) for the Project, whereby the Bank delegates to the FI the decision-making on the use of the Bank funds, including the selection, appraisal, approval and monitoring of Bank-financed subprojects.

The Bank conducts an Environmental and Social Due Diligence on all its prospective Projects to inform its decision-making process, and requires its Client to prepare instruments in compliance with its ESP, comprising an assessment of key activities and project components (including associated facilities) and the development of management plans or planning frameworks. The Bank then supports implementation of the environmental and social mitigation and management measures in projects it decides to finance, requires regular reporting on performances and conducts supervision at regular intervals. The Bank also requires its Clients to disclose relevant information about environmental and social risks and impacts of the Project in a timely and accessible manner, understandable by Project-affected people. It also posts the Client's documentation on its website for consultation.

The Bank requires the establishment of a project-level Grievance Redress Mechanism to receive and facilitate resolution of the concerns or complaints of people who believe they have been adversely affected by the Project's environmental or social impacts, and to inform Project-affected people of its availability. The grievance mechanism includes provisions to protect complainants from retaliation and to remain anonymous, if requested.

AIIB further requires compliance, where relevant to the Project, with three Environmental and Social Standards (ESS), for identification and management of environmental and social risks and impacts:

- AIIB ESS 1: Environmental and Social Assessment and Management;
- AIIB ESS 2: Involuntary Resettlement;
- AIIB ESS 3: Indigenous Peoples.

The following section provides an overview of the key requirements of AIIB's ESS:

#### *AIIB ESS 1: Environmental and Social Assessment and Management*

- Introduces concept of proportionality: ES assessment and management measures are to be proportional to Project risks and impacts;
- Mentions effective mitigation and monitoring measures for quality assessment and management of ES risks and impacts;
- Applies during the course of Project implementation;

- Requires the tracking of risks and impacts and the management of related procedures to be reflected in an Environmental and Social Management Plan;
- Focus: general requirements for the assessment and management structure and process, and specific environmental, social, working conditions and community; health and safety considerations;
- Requires the examination of alternatives to proposed project and related risks and impacts;
- Whatever the risks and impacts involved, AIIB will not finance projects involving the activities included in its Environmental and Social Exclusion List (e.g. forced labour, production of, or trade in illegal or dangerous products such as PCBs, weapons, tobacco, alcoholic beverages);
- Requires the preparation of an Environmental and Social Management Planning Framework (ESMPF) when details are missing at time of project's approval by the AIIB or when the AIIB determines that the ES assessment should be conducted in phases;
- Monitoring results should be documented and communicated in accordance with Information Disclosure requirements;
- Project changes requiring approval from the AIIB;
- Grievance mechanism: Necessary 'to receive and facilitate resolution of the concerns of people who believe they have been adversely affected';
- Information Disclosure addresses the sharing of documents, including of the draft ES assessment documents, in a timely manner and in locations and languages accessible to stakeholders.

#### *AIIB ESS 2: Involuntary Resettlement*

- Focuses on involuntary: 'as a result of: (a) involuntary acquisition of land; or (b) involuntary restrictions on land use or on access to legally designated parks and protected areas';
- Defines 'physical' (relocation, loss of residential land or loss of shelter) and 'economic' (loss of land or access to land and natural resources; loss of assets or access to assets, income sources or means of livelihood) displacements;
- Introduces notions of time, of proportion, and of direct correlation with project: "involuntary resettlement of the recent past or foreseeable future that is directly linked to the Project"; "whether such losses and involuntary restrictions are full or partial, permanent or temporary";
- Includes notions of obligation and of quality of restoration: 'If these impacts are found to be adverse at any stage of the Project, the Client is required to develop and implement a management plan to restore the livelihoods of affected persons to at least pre-Project level or better;'

Requirements proportionate to risks and impacts of the involuntary resettlement:

- Resettlement Plan or Framework proportional to degree of impacts in accordance to scope of physical/economic displacement and vulnerability of the displaced;

- Abbreviated Resettlement Plan allowed where less than 200 people displaced or where entire displaced population not physically displaced and lose less than 10% of productive assets;
- Where impacts significant, consider transforming Involuntary Resettlement as a stand-alone project;
- Where risks and impacts highly complex and sensitive, encourages a social preparation phase before compensation and resettlement decision- making (involving consultation with affected people and host population): to build capacity of the vulnerable and address resettlement issues (include social preparation cost in resettlement budget);
- Can use existing formal or informal grievance mechanisms if well designed and implemented and seen suitable by the Bank. Grievance mechanisms process to be transparent and understandable, gender-sensitive, culturally appropriate and readily accessible to affected people;
- Information disclosure to include grievance redress and outcomes reports, draft and final resettlement plans/frameworks, updates, and monitoring reports to all stakeholders in the same manner;
- Specified client should improve the standards of living of the displaced poor and vulnerable to at least national minimum standards, including access to social protection systems, legal and affordable access to land and resources/housing in rural/urban areas, and appropriate income sources in urban areas;
- Specifies that should not include compensation for people on illegally settled land;
- Requires developing procedures for displaced people who are under administrative or legal review;
- Reminds to closely supervise implementation;
- Wait for compensation and other resettlement entitlements provision before any displacement.

### *AIIB ESS 3: Indigenous Peoples*

- Invites clients to take into account national legislation, customary law and any international conventions to which the country is a party in assessing the above characteristics;
- Includes vulnerability in its generic definition of 'Indigenous Peoples': term refers 'to a distinct, vulnerable, social and cultural group possessing the following characteristics in varying degrees...';
- Asks for an Indigenous Peoples Framework to be prepared when project details undefined;
- Specifies that a social assessment should be conducted to define project impacts on Indigenous Peoples o Assessment should be culturally appropriate and gender-sensitive o Both positive and adverse impacts should be assessed;
- Participation of Indigenous Peoples should also be in monitoring and evaluation of arrangements;
- Where FPIC is especially required, engage suitably qualified and experienced independent experts for identifying risks and impacts on Indigenous Peoples;



- Documentation of FPIC evidence of agreement should also demonstrate broad community support (otherwise AIIB will exclude doubtfully supported activities from project);
- Impacts on protected areas and natural resources (access restriction, displacement) should particularly be avoided or otherwise benefits shared equitably;
- Requires grievance mechanism, with same conditions then for Involuntary Resettlement grievance mechanism (see above). Have provisions for complainants to remain anonymous and be protected from retaliation if requested.

## 2.8 PROJECT CLASSIFICATION AND CATEGORISATION

### 2.8.1 DOE, Ministry of Environment and Forest, Bangladesh

Depending upon location, size and severity of pollution loads, projects/ activities have been classified in the ECR, 1997 into four categories: *Green*, *Orange A*, *Orange B* and *Red*, respectively, to nil, minor, medium and severe impacts on important environmental components (IECs).

As per the *Schedule-1* of the ECR 1997, corresponding category related to power plants and associated facilities (e.g. laying of natural gas pipeline from nearest distribution point up to the power plant; water pipelines for intake and outfall; and fuel oil supply pipeline), fall under *Red Category* for the following components:

- Item 6 : power plants
- Item 64: water, power and gas distribution line laying/ relaying/ extension.

### 2.8.2 Project Classification as per ADB Safeguard Policy Statement and AIIB ESS

Categorization for the proposed Project was undertaken by using ADB's Rapid Environmental Assessment (REA), Involuntary Resettlement (IR) and Indigenous People (IP) Assessment checklists during the screening and scoping exercise. The REA checklist of the Project for the Thermal Power Plant Sector, Involuntary Resettlement (IR) Assessment checklist and Indigenous People (IP) Assessment checklist has been presented in *Annex F*. The findings of the assessment are presented in *Table 2.6*.

**Table 2.6 Project Categorisation as per ADB Safeguards and AIIB ESS**

S. No.	Criteria	Relevance	Remarks	Category
<b>1 Environmental Categorization</b>				
(a)	Irreversible	Environmental issues and impacts of the Project are anticipated during the construction and operation of the power plant and development	Irreversible impacts due to the Project include: <ul style="list-style-type: none"> <li>• Increase noise and vibration during the plant construction and operation</li> <li>• Change in air quality due to existing and proposed</li> </ul>	<i>Based on limited irreversible, diverse and cumulative impacts, it should be categorized as 'B'.</i>

S. No.	Criteria	Relevance	Remarks	Category
		of associated infrastructure (such as gas pipeline, limited dredging activity for HSD transportation to the site, construction and operation of jetty at Dehular Khal, water supply system etc.).	<p>projects</p> <ul style="list-style-type: none"> <li>Affected aquatic ecology and surface water quality due to hot water discharge from the power plant</li> <li>Occupational health and safety;</li> <li>Community health and safety;</li> <li>Risks due to transport, storage and handling of highly flammable chemicals;</li> <li>Associated development in the area.</li> </ul>	
(b)	Cumulative	225 MW operational power plant in the neighbourhood. Operational brick kilns in the study area. New developments which may come up in future due to availability of power.	Cumulative impacts on physical, biological and socio economic environmental conditions	
(c)	Diverse	Nature of activities	The nature of activities is not diverse for the area, as there is already an operational gas fired power plant. However, as the proposed project will be based on dual fuel (natural gas and HSD) and there will some degree of diversification due to operation of plant with HSD.	
(d)	Unprecedented	Change in landuse	<p>The establishment of the project will result in permanently change in land use of the project site and planned sub components areas (like access road, gas pipeline etc.) from agricultural to industrial.</p> <p>Total land required for the project is 17.28 acres, out of which, 11.5 acres is already acquired and is under the possession of BPDB and 5.78 acres of agricultural land will be acquired for the project. In addition to that about 5.5 acres of RoW will be required for gas pipeline.</p>	
<b>2</b>	<b>Involuntary Resettlement Categorization</b>			

S. No.	Criteria	Relevance	Remarks	Category
(a)	Mode of Acquisition	By Land Lease Agreement	11.5 acres of land for the Project will be obtained through lease from BPDB. In addition to that about 5.78 acres of private land will be purchased to meet the additional land requirement for the dual fuel fired power plant. Furthermore, about 5.5 acres of land RoW will be required, for which the mode of acquisition will be through the Sundarban Gas Company's implementation of the land acquisition regulations in Bangladesh.	<i>A majority of land required for the power plant entails a transfer of land from BPDB.</i>  <i>However, the purchase of additional land for the power plant, access road and the gas pipeline entails physical and economic displacement of households, formal titleholders and land users.</i>  <i>While a majority of land is likely to be procured through negotiated settlement, government-led land acquisition will be triggered for the gas pipeline.</i>
(b)	Precedence	BPDB currently own the land (33.07 acres) and intend to lease an area of 11.5 acres to the Project Proponent for a period of 22 years. In addition, it is intended that approximately 5.78 acres of land would be required for the project development.	The proposed project was an agricultural land and the site was developed after 2013. The satellite imagery shows that the site had no settlements and any permanent vegetation (trees). Therefore, R&R issue is not applicable for this project.	<i>In addition, there may also be certain economic and livelihood impacts due to the proposed project activities in and around Dehular Khal and Tetulia river.</i>  <i>However, the impacts are not likely to be significant.</i>  <i>Hence on Involuntary Resettlement, the Project shall be categorised as 'B'.</i>
(c)	Irreversible	Project affected households	As reported that the affected people has already been compensated. For additional land, the affected people will be compensated as per Govt. regulation and negotiation with the land owners. The alignment of gas pipeline is currently unknown and assessment of project affected households will be determined based on social survey.	
<b>3 Indigenous People Categorization</b>				
(a)	Presence	Existence of indigenous people	The census data (2011) of Bangladesh shows that in the entire Burhanuddin Upazilla, there are only 2	<i>In case of no foreseen adverse impact, project shall be</i>

S. No.	Criteria	Relevance	Remarks	Category
			households of ethnic minority population and within the project footprint area including Kutba Union, where the project will be located; there is no population under this group. (BBS 2013)	<i>categorized as 'C'</i>
(b)	Impact	Impact on indigenous/ ethnic/ scheduled tribes	No adverse impact on the Ethnic Minority is foreseen	

### 2.8.3

#### *Project Classification as per IFC Performance Standards*

With reference to the IFC's environmental and social screening criteria, it is anticipated that the proposed Project will fall under *Category B* for the following reasons:

- **Irreversible:** Environmental and social impacts of the project are anticipated during the construction and operation of the power plant. The irreversible impacts will encompass increase noise and vibration during the plant construction and operation, change in air quality due to existing and proposed projects, affected aquatic ecology and surface water quality due to hot water discharge from the power plant in case of accidental discharge without cooling, occupational health and safety issues, community health and safety issues, risks due to transport, storage and handling of highly flammable chemicals as well as toxic chemicals and associated development in the area. These impacts will irreversible in nature without any mitigation measures and hence require proper attention to mitigate and minimise the overall impact in the project influence area.
- **Cumulative:** Cumulative impacts on physical, biological and socio-economic environmental conditions are anticipated due to existing power plant and proposed power project.
- **Unprecedented:** The Project is a green-field project. The Project site is a developed land, already earmarked for the power plant. BPDB has already having an operational power plant next to it. The Project and its impacts are therefore having precedence; however, this development is going to attract more industrial and infrastructure development in the neighbourhood, which is unprecedented. There will be no change of land use due to the Plant; however, associated infrastructure will require additional agricultural land.

### 2.9

#### *APPLICABLE EHS STANDARDS*

As per the Additional General Instructions (Section 6.4 of the RFP for the Project), the Project shall have to comply with Bangladesh environmental, health and safety laws and World Bank Group Guidelines with special

attention to comply with the Bangladesh (GOB Environmental Conservation Rule 1997) and World Bank Group requirements regarding air emissions (December 2008).

Therefore, the EHS standards as stipulated in ECR 1997 and amendments thereof as well as in the IFC EHS guidelines (General and Thermal Power Plant specific) for air quality, surface and ground water quality, ambient noise levels, emissions and effluent discharge will be applicable. Further, from the existing substation and transmission lines, electro-magnetic field and corona noise effects may have some impacts, which will be used by the proposed project as well.

The ADB SPS policy Statement 2009 (SPS) also states, "During the design, construction, and operation of the project the borrower/client will apply pollution prevention and control technologies and practices consistent with international good practice, as reflected in internationally recognized standards such as the World Bank Group's Environment, Health and Safety Guidelines. These standards contain performance levels and measures that are normally acceptable and applicable to projects." For this purpose IFC EHS guidelines are recommended.

## 2.10 APPLICABLE ENVIRONMENTAL STANDARDS BOTH NATIONAL AND INTERNATIONAL

The relevant environmental standards (national as well as international) for thermal power plants as applicable to the proposed Project are presented in the following tables:

**Table 2.7 Air Emission Standards/ Guidelines**

Parameter	Unit	Bangladesh*	World Bank**
PM <sub>10</sub>	mg/Nm <sup>3</sup>	150	50 (liquid fuel)
		-	N/A (natural gas)
SO <sub>2</sub>		[1]	Use less than 0.5% sulphur fuel (liquid fuel)
		-	N/A (natural gas)
NO <sub>x</sub>	mg/Nm <sup>3</sup>	-	152 (74 ppm) – liquid fuel
	mg/Nm <sup>3</sup>	30 ppm	51 (25 ppm) – natural gas
Dry Gas, Excess	%		15 (natural gas)
O <sub>2</sub> content	%		15 (liquid fuel)

Note:

[1] In Bangladesh, SO<sub>2</sub> concentration in gas emissions is not regulated by law, except regulations concerning stack heights.

\* Schedule 11 (Standards for Gaseous Emission from Industries or Projects) of the Environmental Conservation Rules, 1997.

\*\* Emission Guidelines for Combustion Turbines, WB/IFC EHS Guidelines for Thermal Power Plants (Source: EU (LCP Directive 2001/80/EC October 23 2001), EU (Liquid Fuel Quality Directive 1999/32/EC, 2005/33/EC), US (NSPS for Stationary Combustion Turbines, Final Rule – July 6, 2006).

■ Represents the standard values applicable to the Project.

**Table 2.8 Ambient Air Quality Standards/ Guidelines**

Parameter	Bangladesh**		WHO ***	
	24 hourly (µg/m <sup>3</sup> )	Annual (µg/m <sup>3</sup> )	24 hourly (µg/m <sup>3</sup> )	Annual (µg/m <sup>3</sup> )

Parameter	Bangladesh**		WHO ***	
	24 hourly (µg/m <sup>3</sup> )	Annual (µg/m <sup>3</sup> )	24 hourly (µg/m <sup>3</sup> )	Annual (µg/m <sup>3</sup> )
SPM*	200	-	-	-
PM <sub>10</sub>	150	50	100 (interim target - 2)	50 (interim target - 2)
PM <sub>2.5</sub>	65	15	37.5 (interim target - 3)	15 (interim target - 3)
SO <sub>2</sub>	365	80	50 (interim target - 2)	--
NO <sub>x</sub>	-	100	200 (1 hourly)	40
CO*	10,000	-	10,000	-

Note:

\* SPM and CO concentrations and standards are 8-hourly only.

\*\* The Bangladesh National Ambient Air Quality Standards have been taken from the Environmental Conservation Rules, 1997 which was amended on 19<sup>th</sup> July 2005 vide S.R.O. No. 220-Law/2005.

\*\*\* WHO Ambient Air Quality Guideline Values (2005 and 2000), which are also being referred in the World Bank and IFC's General EHS Guidelines (2007)

■ Represents the standard values applicable to the Project.

As per the WB/IFC General EHS guidelines, ambient air quality results need to be compared with the relevant ambient air quality guidelines and standards by applying national legislated standards, or in their absence, the current WHO air quality guidelines or other internationally recognised sources, such as the United States National Ambient Air Quality Standards and the relevant European Council Directives. *Since, Bangladesh has its own national ambient air quality standards, these local standards are considered as the applicable standard for the project.*

**Table 2.9 Effluent Standards/ Guidelines**

Parameter	Unit	Bangladesh*	WB/IFC**
pH	-	6-9	6-9
Total Suspended Solids (TSS)	mg/l	150	50
Oil and grease	mg/l	10	10
Total residual chlorine	mg/l	-	0.2
Chromium (total)	mg/l	0.5	0.5
Copper	mg/l	0.5	0.5
Iron	mg/l	2.0	1.0
Zinc	mg/l	5.0	1.0
Lead	mg/l	0.1	0.5
Cadmium	mg/l	0.5	0.1
Mercury	mg/l	0.01	0.005
Arsenic	mg/l	0.2	0.5
Temperature increase at the edge of the mixing zone	°C	40 (summer) 45 (winter)	Site specific requirement to be established by the EA. Elevated temperature areas due to discharge of once-through cooling water (e.g., 1 Celsius above, 2 Celsius above, 3 Celsius above ambient water temperature) should be minimized by adjusting intake and outfall design through the project specific EA depending on the sensitive aquatic ecosystems around the discharge point.

Note:

\* Schedule 10 (Standards for Waste from Industrial Units or Projects Waste) of the Environmental Conservation Rules, 1997.

\*\* Effluent Guidelines, WB/IFC EHS Guidelines for Thermal Power Plants.

■ Represents the standard values applicable to the Project.

**Table 2.10 Standards for Sewage Discharge**

Parameter	Unit	Standard Limit (Bangladesh)*	WB Guideline Values
BOD	mg/l	40	30
Nitrate	mg/l	250	-
Phosphate	mg/l	35	-
Suspended Solid	mg/l	100	50
Temperature	°C	30	-
Coliform	No./100 ml	1000	400
pH		-	6-9
COD	mg/l	-	125
Oil & Grease	mg/l	-	10
Total Nitrogen	mg/l	-	10
Total Phosphorous	mg/l	-	2

**Notes:**

This limit shall be applicable to discharges into surface and inland waters bodies. Sewage shall be chlorinated before final discharge.

\* Schedule 9 (Standards for Sewage Discharge) of the Environmental Conservation Rules, 1997

■ Represents the standard values applicable to the Project.

**Table 2.11 Noise Level Standards/ Guidelines**

Category of Area/ Receptor	Bangladesh*		IFC-WHO***	
	Day (dB(A))	Night (dB(A))	Day (dB(A))	Night (dB(A))
Silent Zone	45	35	55	45
Residential Area	55	45	55	45
Mixed Area	60	50	-	-
Commercial Area	70	60	70	70
Industrial Area	75	70	70	70

**Note:**

\* The Bangladesh National Ambient Noise Standards have been taken from Schedule 4 (Standards for Sound) of the Environmental Conservation Rules, 1997 amended September 7, 2006.

\*\* Guidelines values are for noise levels measured out of doors. Source: Guidelines for Community Noise, World Health Organization (WHO), 1999.

\*\*\* As per IFC EHS noise level guidelines, Noise impacts should not exceed the levels presented in the above table or result in a maximum increase in background levels of 3 dB at the nearest receptor location off-site.

■ Represents the standard values applicable to the Project.

In addition to the above, working noise limits which trigger noise protection to be provided to the workers shall be 85 dB(A) for an exposure duration of 8 hours per day. For every 3 dB(A) increase in sound levels, the 'allowed' exposure period or duration should be reduced by 50 percent<sup>1</sup>.

It is evident from the above tables that except noise level standards, the WB/IFC guidelines are more stringent than the local standards. The RFQ for the Project also states that the Project shall comply with the Bangladesh environmental, health and safety laws and World Bank Group Guidelines. Hence, it is mandatory for the Project to meet the more stringent standards, as necessary.

<sup>1</sup> The American Conference of Governmental Industrial Hygienists (ACGIH), 2006



There is no Bangladesh soil or groundwater regulation/standard. In the absence of local country standards, it is ERM's practice to use 'Dutch Ministry of Public Housing, Land-use and Environmental Guidelines - Soil and Groundwater Standards' to assess soil and groundwater quality and to determine the need, if any, for remedial action.

The most recent issue of the Dutch Standards is published in the 'Soil Remediation Circular in 2009. These standards are used in the Netherlands to evaluate and provide targeted 'clean-up' levels for a range of possible pollutants in soils and groundwater (*Table 2.12.*)

The contaminants are subdivided into two categories ('T') and ('I'), depending upon the concentrations, and classified as follows:

- 'T' (Target) Values characteristic of clean, uncontaminated soils and waters; and
- 'I' (Intervention) Values define sites where some form of intervention would be required.

**Table 2.12** *Target values and soil remediation intervention values and background concentrations soil/sediment and groundwater for metals*

Metals	EARTH/SEDIMENT (mg/kg dry matter)			
	Dutch National concentration (BC)	background	Target Value (incl. BC)	Intervention Value
Antimony	3		3	15
Arsenic	29		29	55
Barium	160		160	625
Cadmium	0.8		0.8	12
Cobalt	100		100	380
Copper	9		9	240
Mercury	0.3		0.3	10
Lead	85		85	530
Molybdenum	0.5		3	200
Nickel	35		35	210
Zinc	140		140	720

*Source:* Dutch Ministry of Public Housing, Land-use and Environmental Guidelines Soil and Groundwater Standards

*Values for soil/sediment have been expressed as the concentration in a standard soil (10% organic matter and 25% clay).*

**3.1 PRELUDE**

The Project Description sets out the scope of the Project features and activities, with particular reference to the aspects which can impact on the environment. Details of the Project facilities' design characteristics, as well as planned and unplanned Project activities, are provided in the subsequent sections of this chapter.

The proposed dual fuel CCPP of 225 MW (Gas and HSD) will be located in Bhola district of Bangladesh. The Project will be implemented BOO basis under the GOB's Policy. The Plant will operate on natural gas as its primary fuel and is designed to operate on HSD as the back-up fuel. Power generated will be sold under a 22 year Power Purchase Agreement ("PPA") with the Bangladesh Power Development Board (BPDB).

NBBL is entering into a GSA with Sundarban Gas Company Ltd. (SGCL), a subsidiary of state-owned Petrobangla and a FSA with state-owned BPC for natural gas and HSD supply to the Plant, respectively. The water requirements for the Project will be met through Dehular Khal, which is flowing on the western boundary of the Project site. For the proposed project a new 230kV Gas Insulated Substation (GIS) will be constructed adjacent to existing outdoor 230kV switchyard. The existing switchyard will be connected to the new GIS and the total power evacuation of both the projects (existing BPDB project and proposed NBBL project) will be through the existing 230 kV overhead transmission lines to Barisal Substation and onward transmission to the Power Grid Company of Bangladesh (PGCB) grid.

**3.2 LOCATION**

The Project site is located at Kutba Union of Burhanuddin Upazilla in Bhola District of Bangladesh. A location map of the project site is presented in *Figure 1.1*. The project site is situated on the right bank of Dehular Khal, beside an existing 225 MW combined cycle gas based power plant of the BPDB. The nearest town is Burhanuddin, which is at a distance of 3 Km from the proposed project and Bhola District Headquarters is about 28 km north (road distance).

Aerial view of the land required for the project with demarcation of Project site, is presented in *Figure 3.1* and site layout plan of the Project has been presented in *Figure 3.2*. The entire power generation complex has been raised during the site preparation by BPDB and concrete wall has been constructed on the western side of the project boundary, whereas about 3 m high has been constructed along other three sides of the site for flood protection, which is

clearly visible in the aerial view of the area. The Project site co-ordinates are as follows:

- N Corner : 22°28'53.72"N, 90°42'32.95"E
- NW Corner : 22°28'53.87"N, 90°42'29.39"E
- S Corner : 22°28'36.46"N, 90°42'35.78"E
- SE Corner : 22°28'37.74"N, 90°42'39.03"E

Figure 3.1 Aerial View of the Project Site in NBBL Power Generation Complex

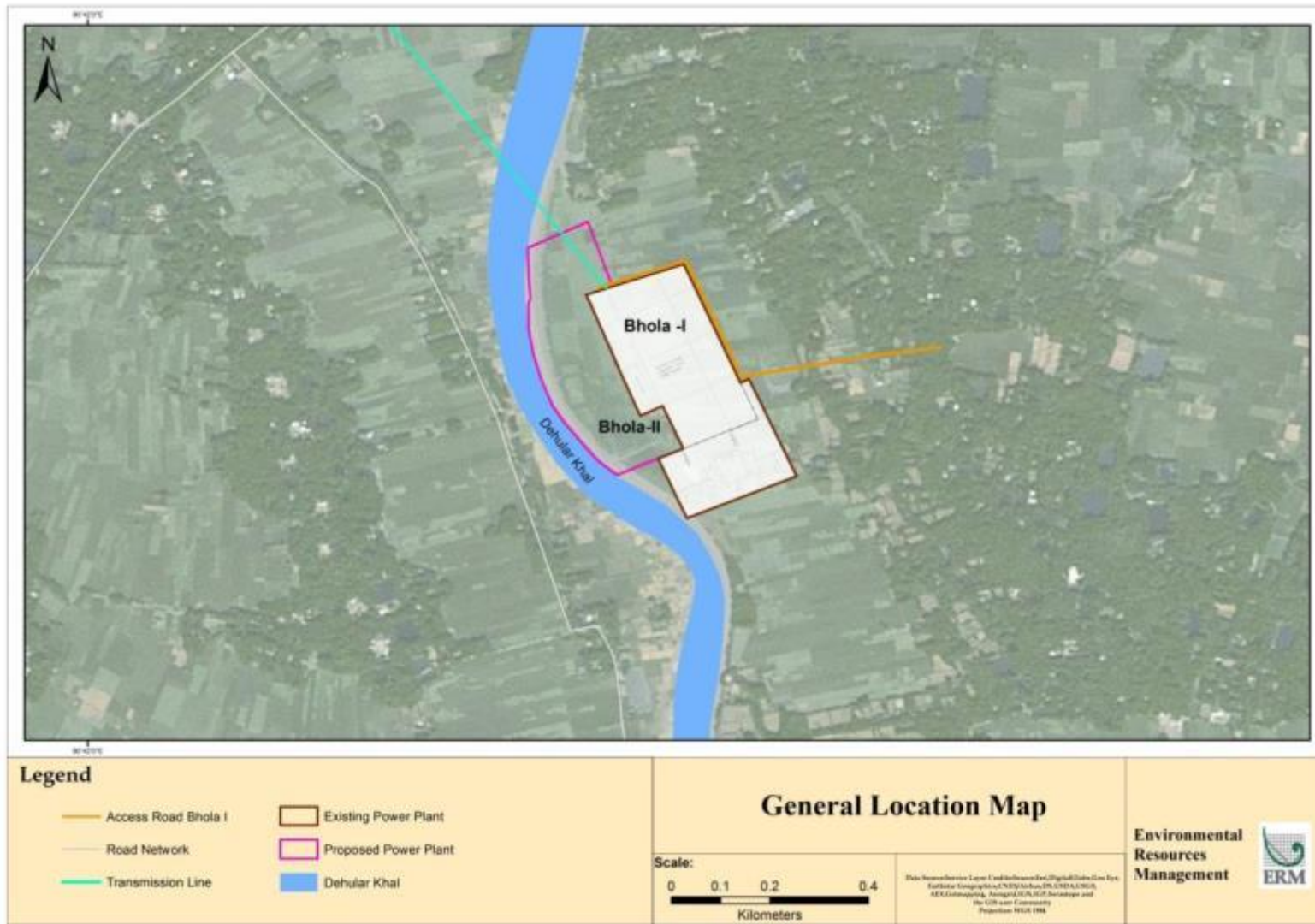
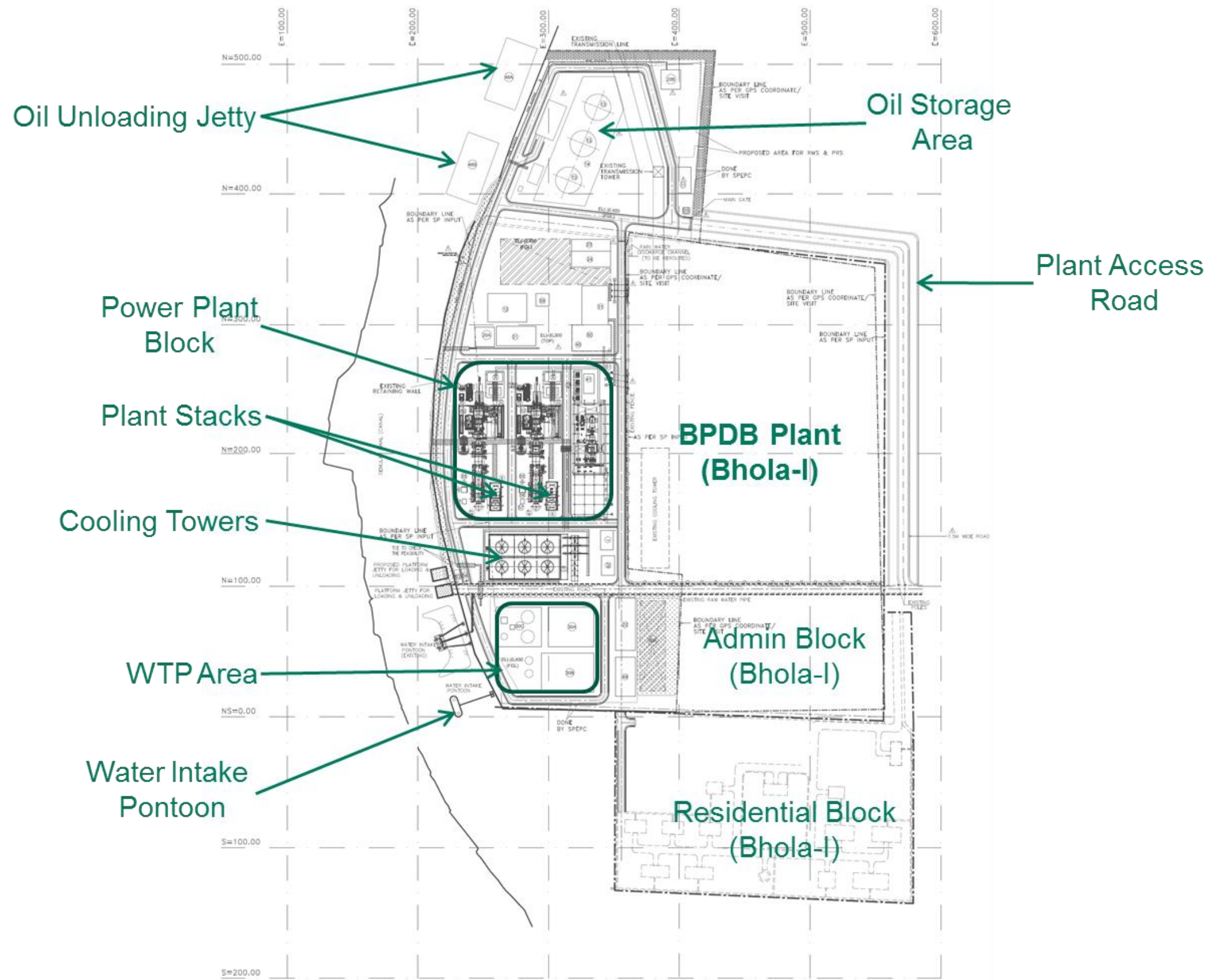


Figure 3.2 Layout Plan of proposed Project



Source: NBBL

### 3.3

#### KEY FEATURES OF THE SITE AND SURROUNDINGS

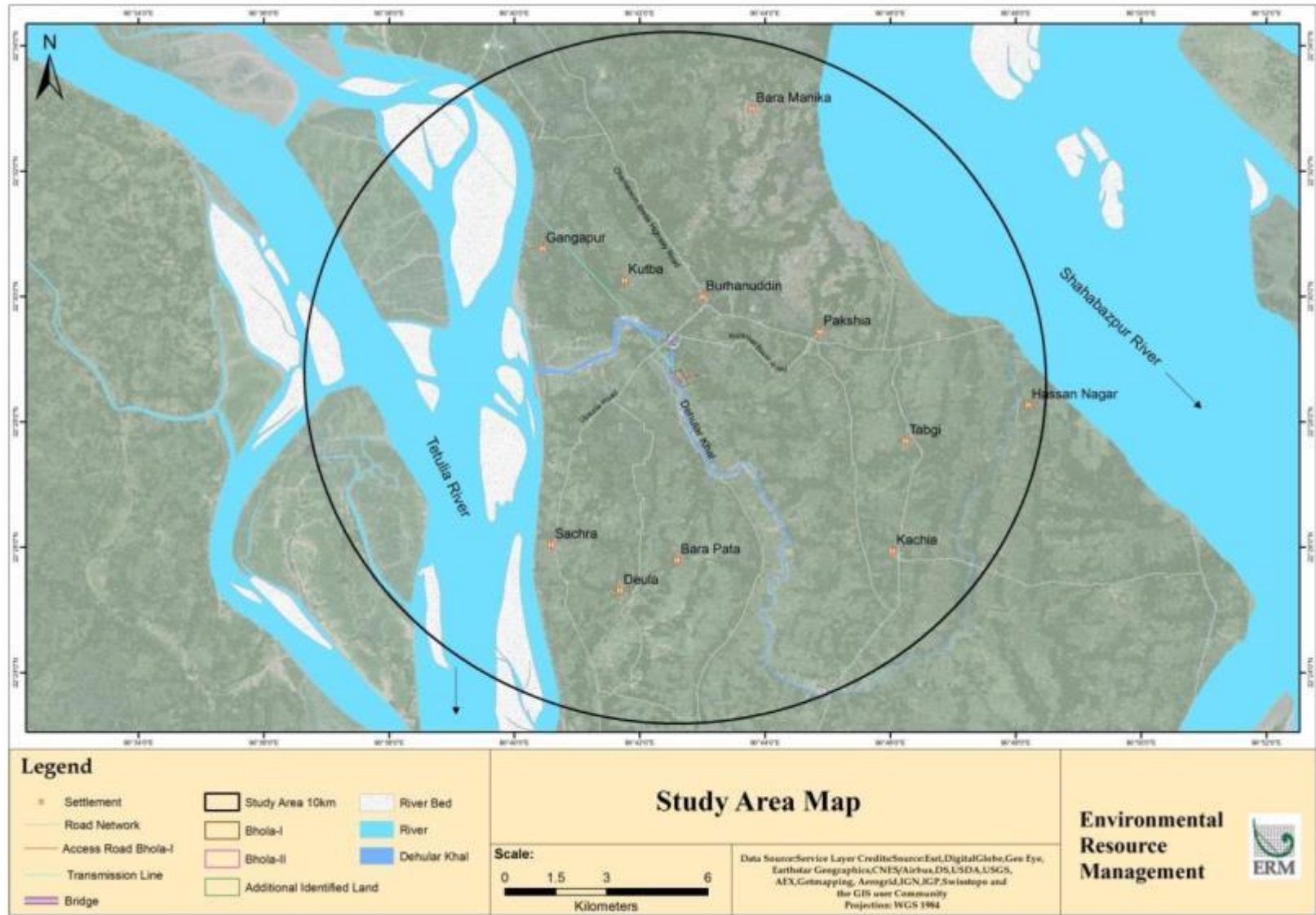
The proposed Project is located in Bhola District, the largest riverine delta island of the world, with an area of 3,403.48 km<sup>2</sup> (BBS 2013). Bhola District in Barisal Division is bounded by Lakshimpur and Barisal districts on the north, Bay of Bengal on the south, Lakshimpur and Noakhali districts, Meghna (lower) River and Shahbazpur Channel on the east, Patuakhali district and Tentulia River on the west (BBS 2013).

The Project site is situated in Burhanuddin Upazilla of Bhola District, which is approximately 28 km south from the Bhola Town. The terrain of the site is reasonably flat deltaic land bound by the *Dehular Khal*, Tatulia river etc. The Project site with key features in the 10 km radial zone is presented in **Figure 3.3**.

The plot of land is primarily virgin, plain and flat, and the Dehular Khal (canal), originating from Tatulia river, is passing alongside its western boundary. Dehular Khal has sufficient flow to meet the water requirement of the power plant for operation and maintenance throughout the year. No human settlement or houses exist on the land. In the close vicinity (within 2 km from the centre) of the Project site, small settlements are located eastern, north-eastern and western side.



Figure 3.3 Key Features in the Surroundings



Source: Site reconnaissance survey (March – April 2016)

### **3.4 PLANT CONFIGURATION**

The main power block of the Plant will consist of two dual fuel gas turbine (“GT”), one steam turbine (“ST”), two heat recovery steam generators (“HRSG”) and bypass and main stacks. Emergency diesel generators will be provided to ensure safe shutdown.

#### **3.4.1 Gas Turbine**

The Gas Turbine models for this CCPP are dual fuel (Natural Gas and HSD) GE make Frame 6F.03, 50 Hz machines with dry low NOx burner assembly coupled with individual two (2) pole cylindrical rotor, closed circuit, air cooled generator that delivers power at a voltage of 11.5 kV. The GT will be installed within an acoustic, ventilated enclosure with fire detection and protection systems. The GT will have all associated ancillary equipment and systems required for the safe, efficient and reliable operation of the unit under Simple and Combined Cycle modes.

#### **3.4.2 Heat Recovery Steam Generator**

The HRSG will be of a double pressure, unfired, natural circulation and horizontal type, in accordance with the manufacturer’s standard design. The HRSG will be sized to operate over the full range of ambient temperatures specified. The HRSG consists of an economizer, evaporator, and super-heater tube bank section(s) with finned tubing, as appropriate, to maximize heat transfer.

All pressure parts will be designed, manufactured and will be tested in accordance with “ASME Boiler and Pressure Vessel Code, Section 1, Power Boilers” or equivalent standards.

The HRSG shall exhaust through a separate stack that has a height of 60 m to provide for adequate dispersion of flue gases in accordance with the environmental standards requirements.

#### **3.4.3 Steam Turbine**

The steam turbine will be 3000 RPM, non-reheat, condensing type, coupled directly to a two (2) pole cylindrical rotor, closed circuit, air cooled generator that delivers power at a voltage of 11 kV. The ST exhaust and condenser configuration will be in accordance to manufacturer’s standard design. The ST will be sized to pass the entire quantity of steam generated by the HRSG over the full range of ambient temperatures specified.

#### **3.4.4 Feed Water System**

The feed water system will provide sufficient and reliable feed water to the HRSG. The feed water system will include necessary feed water heaters, de-aerators, feed water pumps, control valves and auxiliaries. One feed water



pump will be in service during 100% plant output with another pump on standby.

#### **3.4.5 *Steam Turbine Condensers***

The steam turbine condenser will be designed and constructed with sufficient margin and spare surface area for the maximum heat rejection duty under both normal operation and turbine bypass operation conditions for the operating regime specified. The condenser will be cooled by the cooling water system.

On the water side, the condenser will be divided horizontally into two independent water paths. This arrangement will facilitate the operation of one half of the condenser when the other half is under maintenance.

The condenser will be provided with integral air cooling zone from where air and non-condensable gases are continuously drawn out with the help of air evacuation system.

#### **3.4.6 *Cooling Water System***

The main cooling water system will provide cooling water to the steam turbine condenser by means of cooling water pumps installed in the cooling tower basin. The warm water from the condenser is returned to the multi-cell induced draft cooling tower, where it is cooled and collected in the cooling tower basin for return to cool the condenser. The induced draft cooling tower will be provided with the capacity for maximum heat rejection duty under all steam turbine operation conditions for the design conditions specified. The cooling tower shall have sufficient cells to allow for one cell to remain in standby under reference operating conditions.

The cooling tower will contain clarified water. A cooling tower chemical injection system will be provided to maintain the appropriate cooling tower chemistry. Cooling tower blow down will be quenched and treated to meet environmental requirements before being sent to the Dehular Khal.

#### **3.4.7 *Natural Gas System***

Natural Gas at a pressure of about 600 psig will be supplied at the plant terminal, which will be further reduced upto 300 psig by installing regulating and metering station (RMS). The gas will be supplied from Shabajpur gas field of Sundarban Gas Company Limited, which is at distance of 6 km. A pipe line will be laid for this purpose by SGCL. The natural gas system will include backup metering equipment and all necessary compressors, pressure reduction stations, gas filter-separators, isolation and control valves, safety valves, and other equipment.

**Table 3.1** *Natural Gas Specification*

Constituent	Minimum Percent by Volume	Maximum Percent by Volume
Methane	85	100
Ethane	0	6
Propane	0	5
Butane-N	0	3
Pentane-N	0	2
Hydrogen Sulphide	0	0
Carbon Dioxide	0	2
Nitrogen	0	3
Oxygen	0	1
Inert (the total combined Nitrogen, Oxygen, Carbon dioxide and any other inert compound)	0	5

Source: (DPR 2016)

### 3.4.8 Fuel Oil System

The fuel oil (HSD) required for gas turbines will be delivered from Bangladesh Petroleum Corporation through jetty and will be stored in three HSD storage tanks. HSD storage tanks will be above ground vertical cylindrical steel tanks with fixed cone roof. Heavier impurities that may be present in the fuel oil such as water, sludge etc. will settle down gradually to the bottom of the tank. These can be removed from water draw-off sump of the tank through its outlet valve when required. HSD storage tanks will be located within bund wall to retain all oil stored in it in case of a break as well as leakage etc. Fuel oil specifications are presented in *Table 3.2*.

**Table 3.2** *Fuel Oil Specification*

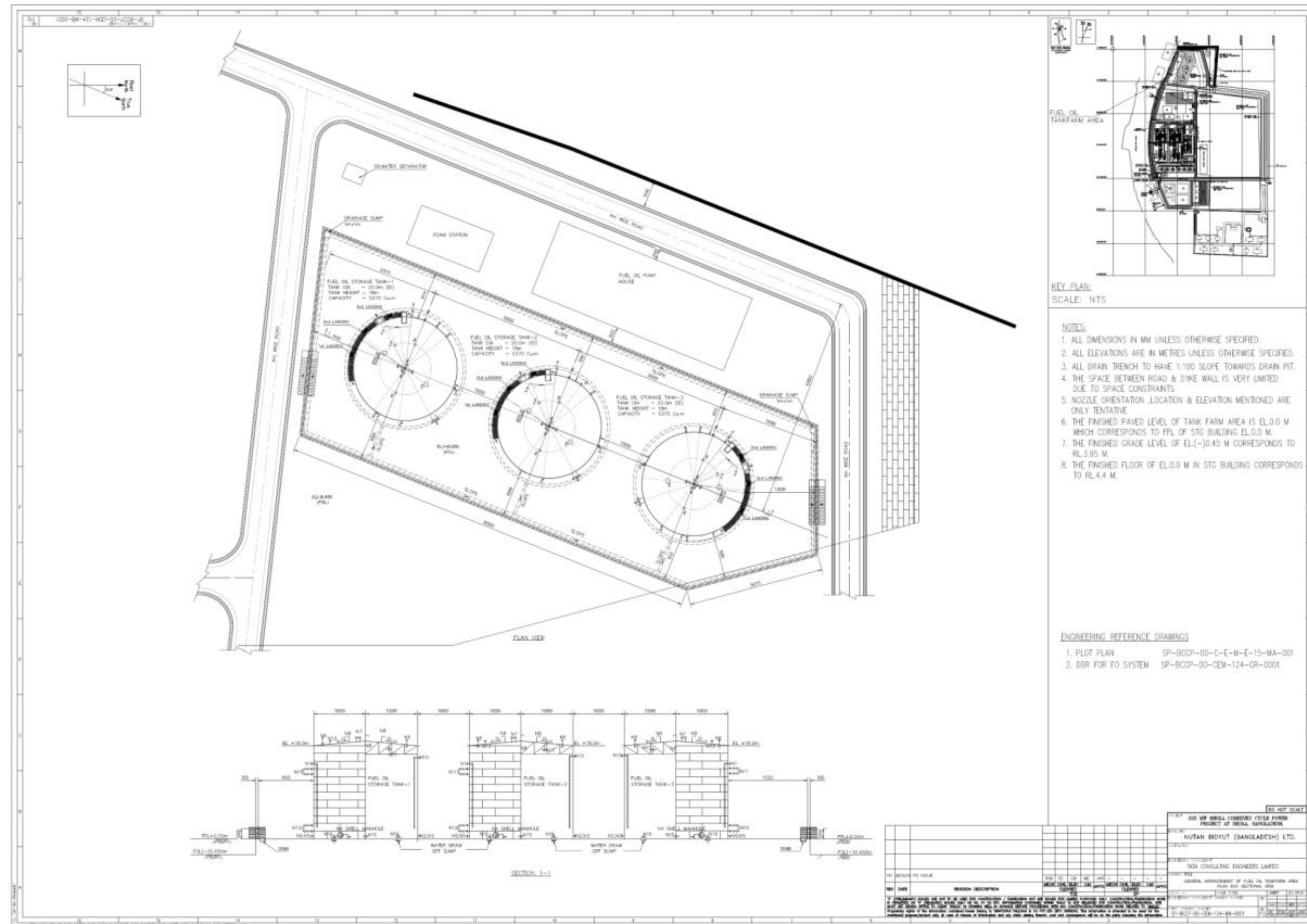
Test	Method	Limit
Density at 15 °C,Kg/L	ASTM D 1298	Min. 0.820 Max. 0.870
Colour, ASTM	ASTM D 1500	Max. 3.0
Neutralization Value:		
Strong Acid No, mg KOH/gm	ASTM D 664	Nil
Total Acid No, mg KOH/gm	ASTM D 974	Max. 0.2
Ash , % mass	ASTM D 482	Max. 0.01
Carbon Residue (Conradson) On 10% bottom, % wt	ASTM D 189	Max. 0.2
Cetane Number	ASTM D 613	Min. 45
Cetane Index Calculated)	ASTM D 976	Min. 45
Pour point, °C	ASTM D 97	Max. 9 (Winter)** Max.12 (Summer)**
Copper Strip Corrosion (3 hours at 100 °C)	ASTM D 130	Max. No. 1
Flash point, PM(cc) / Abel,°C	ASTM D 93/ IP 170	Min. 32
Kinematic viscosity at 38 °C,cst	ASTM D 445	Max. 9.0
Sulphur total, % mass	ASTM D 4294	Max. 0.25
Sediment, % mass	ASTM D 473	Max.-0.01
Water content, % vol.	ASTM D 95	Max. 0.1
Distillation: 90 % vol. recovery, °C	ASTM D 86	Max. 375

Note: Winter shall be the period from November to February (both months inclusive) and rest of the months of the year shall be deemed as Summer.

Source: (DPR 2016)



Figure 3.5 Fuel Oil Storage Tank Layout



### *Electrical Plant and Systems Requirements*

The basic electrical schemes are considering the configuration of 2GT + 2HRSG + 1ST. The generation voltage will be stepped up to 230 KV level by means of Generator transformers which in turn will be connected to the 230 KV Switchyard.

The Power generated from the proposed 225 MW CCPP will be evacuated through 230 KV GIS to be connected to existing 230 KV Bhola-Barisal grid transmission line.

#### *230 KV Substation and Switchyard*

There exists one outdoor type 230kV Air Insulated Substation (AIS) in the existing Bhola-I CCPP. The AIS provides power to the two (2) 230 kV overhead transmission lines to Barisal Substation.

For the proposed Bhola-II CCPP, a new 230kV Gas Insulated Substation (GIS) shall be constructed adjacent to existing outdoor 230kV switchyard. The existing AIS will be now connected to the new 230kV GIS and the total power evacuation of both existing and proposed CCPP shall be through the existing 230 kV overhead transmission lines to Barisal Substation.

#### *Power and Auxiliary Transformers*

The GT and ST generators will be connected to the 230kV GIS through their respective generator transformers. The generator transformers will be connected to the generators through isolated phase bus ducts.

#### *Station Auxiliary Transformers*

The auxiliary power required for the power plant during start-up will be drawn from the 230kV grid through 230/11.5 kV Generator Transformer and the 11.5/6.6 kV Unit Auxiliary Transformer. After start-up the auxiliary power will be provided by the GT generator units.

#### *Generators*

The generator will have a nominal MVA & MW rating so as to suitably match with GT/ST output at all power factors from 0.85 lagging to 0.95 leading. The generator will deliver power at 11.0-15kV, 3 Phase, 50 Hz. The generator phase and neutral terminals shall be brought out for connection to isolated phase bus duct. The star point will be connected to earth through a transformer having the secondary shunted by a resistor.

The generators coupled with gas turbine and steam turbine will be air cooled. Closed loop system will be adopted for the cooling circuit. Closed loop system will be cooled in turn in water-cooled heat exchangers.

Rating: 50 - 90 MVA associated with maximum output of STG and GTG at all power factor between 0.85 lagging and 0.95 leading.

#### *Emergency DG Set*

For the safe shutdown of the plant under emergency conditions, i.e. in case of total power failure, diesel generating set shall be installed for feeding certain essential applications like battery chargers, emergency lighting, essential air conditioning/ventilation and all auxiliaries necessary for barring operation of main turbines. For this purpose, one no. 800kVA, 400V, 3ph, 50Hz DG set has been envisaged. One 400V emergency AC board would be provided. This emergency board will normally be fed from the associated 400V BTG PMCC and DG set will feed power to it in case of AC failure.

### **3.4.10 Water Systems**

Water for a combined cycle plant is required for condenser cooling, cooling of various GTG/STG/HRSG auxiliaries, for plant service water, for potable water, fire water systems and for production of DM water for power cycle make-up and Injection Water for Gas Turbines (for liquid fuel operation).

#### *Water Requirement*

For this project, the condenser cooling water system is open re-circulating type with a wet Cooling Tower and major consumptive water for this system is for make-up to cooling tower only. The total consumptive water requirement for the 225 MW CCPP is at present estimated to be 384 m<sup>3</sup>/hour.

#### *Source of Water*

Consumptive water for the plant will be made available from the nearby canal i.e. Dehular Khal. Raw water intake pumps mounted on pontoon will take direct suction from this canal. There will be no raw water reservoir as the canal has sufficient flow to meet the requirement of this power plant. Further treatment will be carried out in the pre-treatment plant to be installed in the power plant area.

Potable water requirement for the proposed CCPP will be met from the clarified Water. Chlorination/filtering will be carried out to meet the applicable drinking water quality standard.

#### *Water Pre-Treatment Plant*

A pre-treatment plant will be installed to clarify the raw water. Chemicals such as alum and soda ash will be dosed to the water in flash mixer. The clarified water from the over flow of Clarifloculator will be stored in a twin compartment clarified water reservoir of 2 hours storage capacity and used for Cooling Tower make-up, service water, potable water and input water to the DM Plant. The sludge from the water pre-treatment plant will be treated and disposed of suitably. Detailed specification of water treatment plant is

presented in *Annex G* and design basis report for demineralised water system is presented in *Annex H*.

#### *Effluent Treatment Plant*

All the effluent from DM plant, HRSG blowdown, Cooling tower blowdown, STG building floor wash, oily waste from transformer yard will be collected in a water collection/settling tank and will be discharged after proper treatment in effluent treatment plant. Effluents will be collected at CMB, which will act as an equalization basin having at least four (4) hours detention period. Acid and alkali dosing facility is provided at CMB to maintain the pH, BOD and COD. Treated effluent from CMB/ Guard Pond will be either discharged to the local water body or will be used for plantation/ green areas. Design basis reports of ETP and STP are presented in *Annex I* and *Annex J*, respectively.

#### **3.4.11** *Fire Protection System*

For protection of the plant against fire, all plant will be protected by any one or a combination of the following systems:

- Hydrant system (also includes the required number of hydrant pumps electrical motor driven and diesel engine driven).
- Automatic high velocity and medium velocity sprinkler system.
- Portable and mobile chemical extinguishers.
- Inert gas system
- Fire detection and alarm system
- 1 Fire Tender

Clarified water as supplied to the plant will be used for fire-fighting purposes. Dedicated firewater storage of two hours' fire-fighting requirement, will be maintained in the Clarified Water Reservoir itself for fire-fighting purpose. The system will be designed as per the applicable Codes and Standards of National Fire Prevention Association (NFPA), USA. Regulations of local statutory authority as applicable will also be followed.

#### **3.4.12** *Gas Pipeline Interconnection*

The Company will connect to Sundarban Gas Company Limited's Point of Delivery of gas, located at Shahbazpur Gas Field, which is about 6 km away from the Project Site. This underground pipeline will provide a safe and efficient method for transporting gas. A Regulating and Metering Station ("RMS") will be installed by the Company to control the gas flow to the Plant. The interface between SGCL and the Company will be at the RMS. The gas received from SGCL will be regulated at the Site to ensure its suitability for the GT. The gas regulation station will include gas compressors, a filter, a pressure control valve and a flow control valve with full NFPA fire protection system. The specification of natural gas pipeline from Shahbazpur Gas field to the plant RMS (within Project boundary) will be as per following specification.

**Table 3.3** *Natural Gas Pipeline Specification*

<b>Particular</b>	<b>Detail</b>
Design of the transmission pipeline	ANSI B 31.8: Gas Transmission & Distribution Systems
Class rating	ANSI class 600
Welding of pipeline	API Standard 1104
Grade of pipe	API 5LX60, PSL-2 LSAW
Length	Approx. 7 Km
Pressure	400-1000 psi
Diameter	12 inch
Temperature	15-24 °C

Source: NBBL

### **3.4.13** *Operations and Maintenance*

NBBL will recruit the required personnel to operate and maintain the power station. Besides, the operators will be trained by the OEM specialists at their shops and at site to develop requisite expertise for operation of the GE Frame 6F.03 GT in line with OEM recommendation. The O&M staff would be in place during commissioning stage so that they will be associated with the OEM team during pre-commissioning stage of the unit.

The operation and maintenance of the station would be the overall responsibility of the Plant O&M Manager, who would be assisted by a team of experienced executives and operators in the respective field.

Since the infrastructure for maintenance of the specialized plant and machinery may not be readily available near the site, adequate maintenance facilities for day-to-day and minor plant maintenance including a well-equipped workshop and trained technicians would be developed for the project. Major maintenance and annual overhaul will be contracted out to manufacturers or reputed agencies. Odd jobs like, plant cleaning, road and drainage maintenance, plant security, gardening etc. will be contracted out locally.

#### *Maintenance*

The plant will be headed by a Plant Manager, who will have overall administrative as well as technical control of the station and will report to the Plant General Manager. For effective operation, maintenance and administration of the plant adequate number of suitable technical and administrative personnel will be posted under him.

### **3.4.14** *Pollution Monitoring System*

Following environmental parameters will be monitored:

- a. Stack emission
- b. Ambient air quality
- c. Disposed water quality
- d. Noise Level



A Continuous Emission Monitoring System (CEMS) will be installed for round the clock monitoring of SO<sub>2</sub>, NO<sub>x</sub>, PM and CO level from main stack of HRSGs would be carried out. Waste water would be checked for any harmful pollutants before discharging to outfall. Discharge water shall conform to the standards set by the pollution control boards.

A well-defined environmental monitoring program would be instituted with trained and qualified staff that would monitor the ambient air as well as stack gas quality to ensure that the quality of effluents is maintained within the permissible levels. The stack of the heat recovery steam generator would be provided with suitable ports to monitor the flue gas quality from the stacks. Suitable analysers will be provided for exhaust gas quality analysis. The quality of the blow down water from the heat recovery steam generator drums and the other water effluents from the plant would be analysed on a daily basis or as required to ensure that effluents are maintained within the permissible levels.

### 3.5 *PROJECT LIFE CYCLE OVERVIEW ALONG WITH KEY ACTIVITIES AND SCHEDULE*

Life cycle analysis of the project identifies the key issues and concerns that are likely to evolve over the entire lifespan of a project. In the case of the proposed Project, these issues may arise during the site preparation and construction, operation and maintenance, and decommissioning. These issues have been considered in this EIA study, prior to any irreversible actions being undertaken by the Company, contractors and other project associates. The following sub-sections identify the key activities to be completed and facilities to be constructed and operated over the lifetime of this Project. A detailed project execution schedule is presented in *Annex K*.

#### 3.5.1 *Construction Activity*

##### *Site Preparation*

The land adjacent to existing 225 MW Bhola CCPP (Bhola-I) owned by BPDB would be utilized to locate the proposed Power Plant. For developing suitable construction facilities, it would be necessary to develop some of the enabling facilities viz. construction of approach road, boundary wall, some of the in-plant roads, identifying space for construction offices of the sub-contractors of vendors, temporary fire fighting system, construction water and construction power facility etc. prior to taking up any construction work. This preparatory work would be followed by site leveling and grading, construction of in-plant road network for ease of movement of plant and equipment and developing temporary drainage facility and ensuring other facilities viz. construction gate, watch tower, greenery, identifying area for labour hutment etc.

### *Construction Equipment*

The Contractors would bring their own construction equipment. To facilitate site work, project authority would also procure a few useful construction equipment, viz. crawler mounted heavy-duty crane, tractor-trailer, road roller, some transport equipment etc .

### *Construction Materails*

All the mechanical, electrical, civil and I&C construction materials along with consumables will be procured by the contractors of individual package. Cement and reinforcement materials will be sourced from Dhaka, sand and gravels will be sourced from Sylhet and sand is available nearby.

### *Manpower*

Being a grass root power project with adequate industrial activity in and around the area, skilled/unskilled worker would have to come from nearby districts/towns.

It is envisaged that the project wing of NBBL be headed by an executive in the level of General Manager, who will look after the overall activities in compliance with the project schedule. He would be assisted by a team of senior engineers experienced in various disciplines including technical, administration, staff welfare, finance, safety and security, materials management, traffic and legal affairs. Other staff will be recruited progressively as the project activity progresses. Consultant's engineers may be engaged to supervise and monitor different technical activities including compliance of codes, standards, safety requirements, quality, progress etc.

## **3.5.2**

### ***Operation and Maintenance***

NBBL will recruit the required personnel to operate and maintain the power station. Beside, the operators will be trained by the OEM specialists at their shops and at site to develop requisite expertise for operation of the GE Frame 6F.03 GT in line with OEM recommendation. The O&M staff would be in place during commissioning stage so that they will be associated with the OEM team during precommissioning stage of the unit.

The operation and maintenance of the station would be the overall responsibility of the Plant O&M Manager, who would be assisted by a team of experienced executives and operators in the respective field.

Since the infrastructure for maintenance of the specialized plant and machinery may not be readily available near the site, adequate maintenance facilities for day-to-day and minor plant maintenance including a well equipped workshop and trained technicians would be developed for the project. Major maintenance and annual overhaul will be contracted out to manufacturers or reputed agencies. Odd jobs like, plant cleaning, road and

drainage maintenance, plant security, gardening etc. will be contracted out locally.

### 3.5.3 *Decommissioning*

The design life of the power plant is estimated to be 30 years, which is almost 8 years more than the Power Purchase Agreement term. If the Power Purchase Agreement, Land Lease Agreement, Gas Supply Agreement and the other relevant agreements are not extended or renewed and an alternative economical fuel is available, the power plant may be retrofitted to support alternative power generation. This option would be possible, provided the required retrofits and new emission rates meet the applicable standards and guidelines.

If retrofitting is not feasible and the operational life of the Power Plant expires, the power plant will be decommissioned according to the requirements of the authorities at that time.

## 3.6 *RESOURCES AND UTILITIES REQUIRED FOR THE PROJECT*

### 3.6.1 *Land Footprint*

Based on information provided by NBBL (as of January 2017), the land requirement for the Project is estimated to be approximately 22.78 acres for the main project components and associated facilities:

- Approximately 11.5 acres of land was already earmarked by BPDB for the project and the same has been allocated to the Project through a lease agreement;
- Additional 5.78 acres of land will be purchased for the project including the access road and will be transferred to NBBL in 2017;
- Furthermore, about 5.5 acres of right of way (RoW) will be required for the gas pipeline which is likely to be acquired under the Acquisition and Requisition of Immovable Property Ordinance, 1982.

Table 3.4 provides a summary of the land requirement for various components of the project.

**Table 3.4** *Break-up of Land Requirement for the Project*

S. No.	Project Component	Required Land Area (In acres)	Current Status of Land	Proposed Mode of Land Procurement
<i>A</i>	<i>Power Plant</i>			
A.1	Main Power Block	4.3	Under Possession of BPDB	The land will be provided to NBBL by BPDB under a land lease agreement (LLA) for 22 years covering the entire period of Implementation Agreement.
A.2	GIS and sub-station	1.3		
A.3	Cooling Towers and WTP area	1.2		
A.4	Gas Supply Station	1.0	land acquired	
A.5	Fuel oil Facilities	1.7		The lease rent paid to BPDB is off-set by

S. No.	Project Component	Required Land Area (In acres)	Current Status of Land	Proposed Mode of Land Procurement
A.6	Other plant areas	1.7	for the project before 2007	part of Nutan Bidyut (Bangladesh) Ltd.'s equity stake in the company.
	<b>Sub-Total (A)</b>	<b>11.5</b>		
	<b>B Additional Land Requirement*</b>			
B.1	For Plant	4.72	Purchased through negotiated settlement	4.72 acres of land on the northern side is private land and is currently being cultivated, whereas 1.06 acres of land for proposed access road is along the embankment of BPDB power station, which is also private land.
B.2	Access Road to Site	1.06		
	<b>Sub-Total (B)</b>	<b>5.78</b>		
	<b>C Gas Pipeline</b>			
C.1	RoW for Gas Pipeline	5.5	To be acquired by the Sundarban Gas Company under the GSA	About 6 km long gas pipeline. Mostly private land under cultivation. Right of way will be required for underground gas pipeline along the existing gas pipelines of Sundarban Gas Company Limited (from Shahbazpur Gas Field to the Valve Station) and Bhola I CCPP (Valve Station to Plant location).
	<b>Sub-Total (C)</b>	<b>5.5</b>		
	<b>Grand Total (A+B+C)</b>	<b>22.78</b>		

\*Note: Additional land requirement will also be able to meet the requirement of laydown area during the construction phase and construction camp.

### 3.6.2

#### **Earth Filling**

It is proposed to raise the level of the land to match with the finished grade level of the existing BPDB plant, which is at RL (+) 4.10 m. Earth for filling purpose will be drawn from the DoE approved river dredging locations of *Tetulia River*. Approximate sand requirement for this purpose will be approximately 200,000 m<sup>3</sup>. It is understood that approval from BIWTA will also be required for the procurement of sand and other fill material from the dredging locations up to the plant site.

### 3.6.3

#### **Water Footprint**

The water requirement for the construction phase of the Project will be met from Dehular Khal. Analysis of water samples collected from Project site as well as Dehular Khal indicated the quality of water is suitable to be used in the construction phase of the Project. The potable water requirement during the construction phase will be provided by the EPC contractor. The contractor will ensure that the quality of drinking water is compliant with the applicable drinking water standards (Schedule 4 of ECR, 1997). The quantity of water required during the construction phase of the Project is presented in **Table 3.5**.

**Table 3.5 Water Requirement during the Construction Phase**

S. No.	Purpose	Quantity (m <sup>3</sup> /day)
1	Concreting	40
2	Curing/ cleaning	30
3	Dust suppression (as applicable)	10
4	Site office and other utilities	10
5	Others	10
<b>Total</b>		<b>100</b>

Note: These are the peak quantities and the actual consumption will vary depending upon the construction activities.

The water requirement during the construction and operations phases will be met through the *Dehular Khal* which has sufficient flow throughout the year. In addition, as the site is prone to inundation during the normal flood season, earth filling of the site will be required as per HFL requirement. The water requirement during the operation phase of the Project will be primarily for cooling water and “make up” water requirements. The water requirement during the operation phase is presented in *Table 3.6* and the water balance diagram shown in *Figure 3.6*.

The potable water requirement during the operation phase will be met through *Dehular Khal*. A potable water treatment plant will be installed so that quality of drinking water is compliant with the applicable drinking water standards (Schedule 4 of ECR, 1997). The industrial wastewater treatment flow diagram has been presented in *Figure 3.7*.

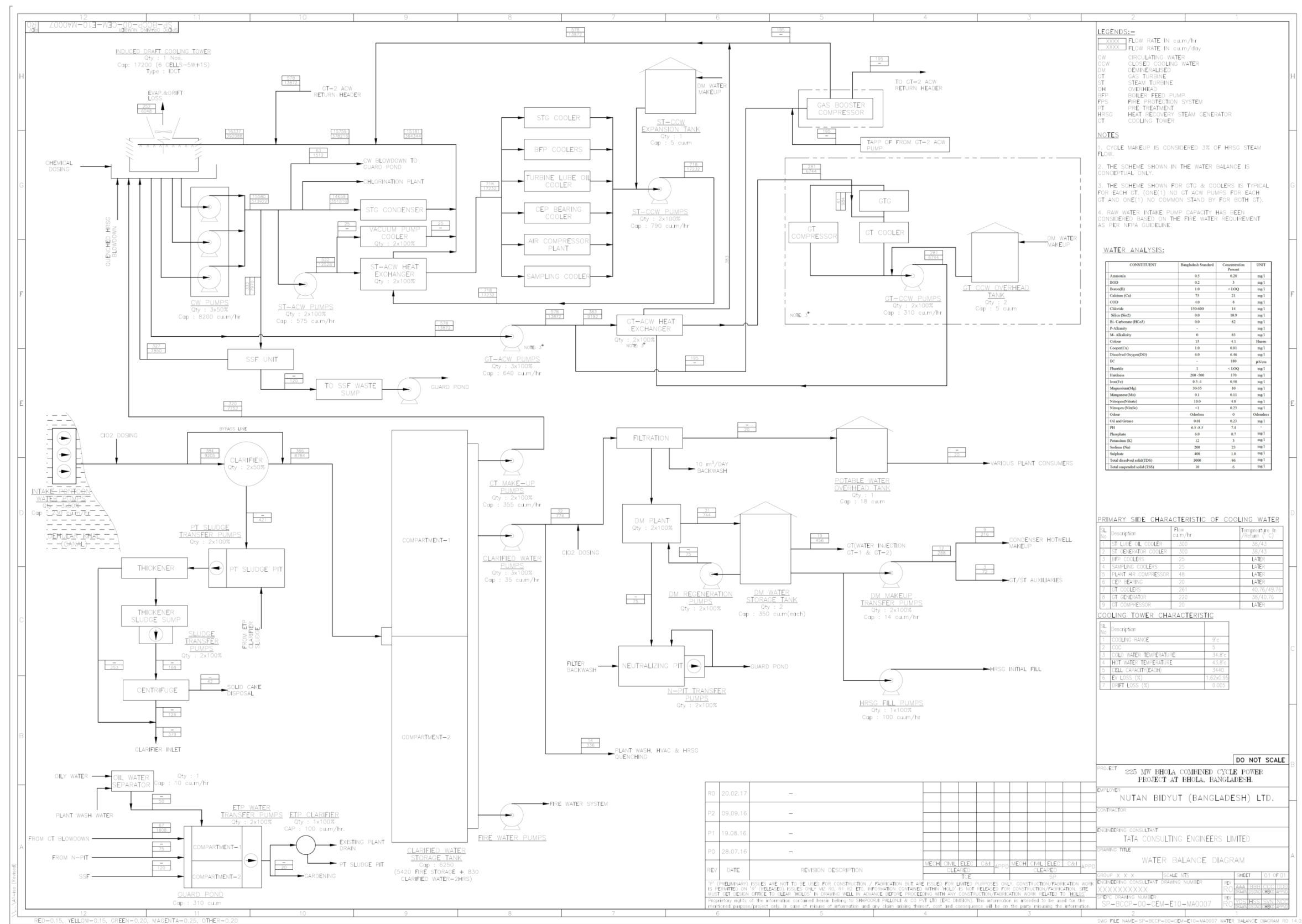
**Table 3.6 Raw Water Requirement during the Operation Phase**

S. No.	Purpose	Quantity (m <sup>3</sup> /hr)
1	Cooling tower make-up	320.00
2	DM Plant	31.00
3	Service Water for WTP, HVAC, Misc.	14.00
4	Potable Water	1.00
5	Sludge Treatment Plant (Raw water treatment)	18.00
<b>Total</b>		<b>384</b>

\* In addition to cooling, fire water storage (2 hours as per NFPA) will be available.

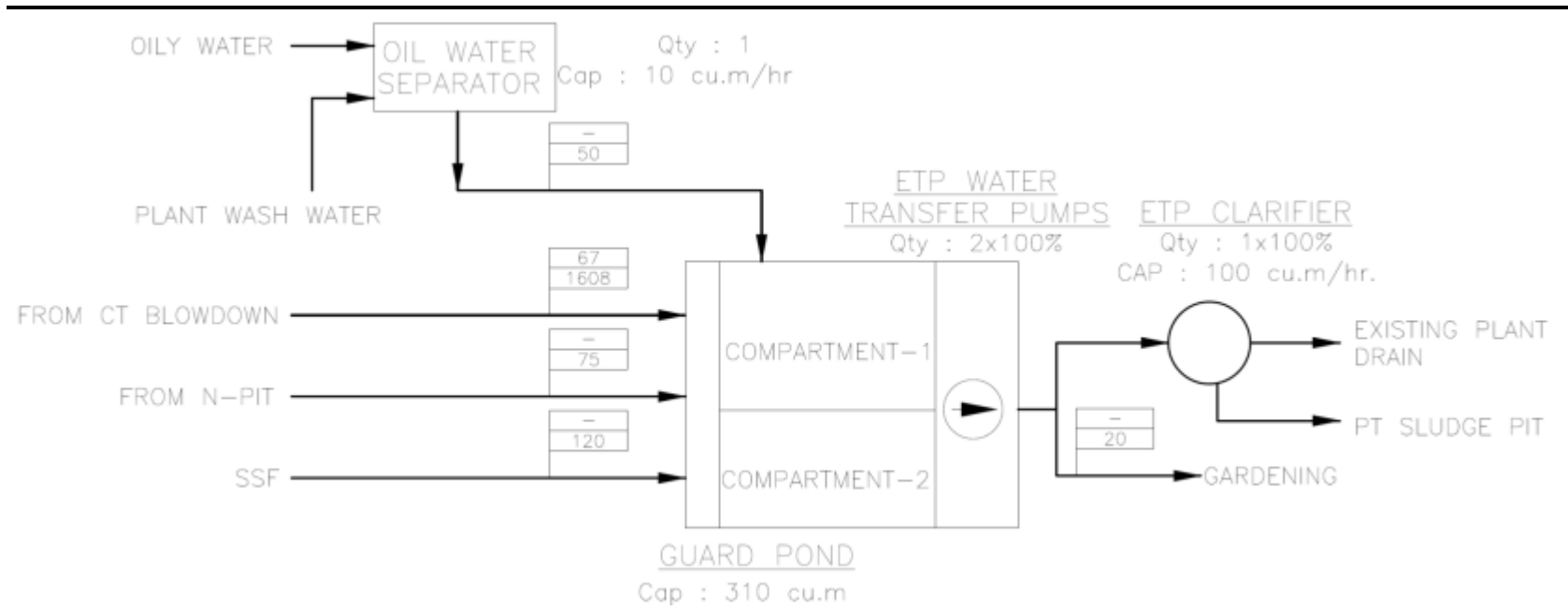
Schematic flow diagram of ETP and STP are presented in *Figure 3.7* and *Figure 3.8*, respectively. Design basis report of the same are presented in *Annex I* and *Annex J*.

Figure 3.6 Water Balance



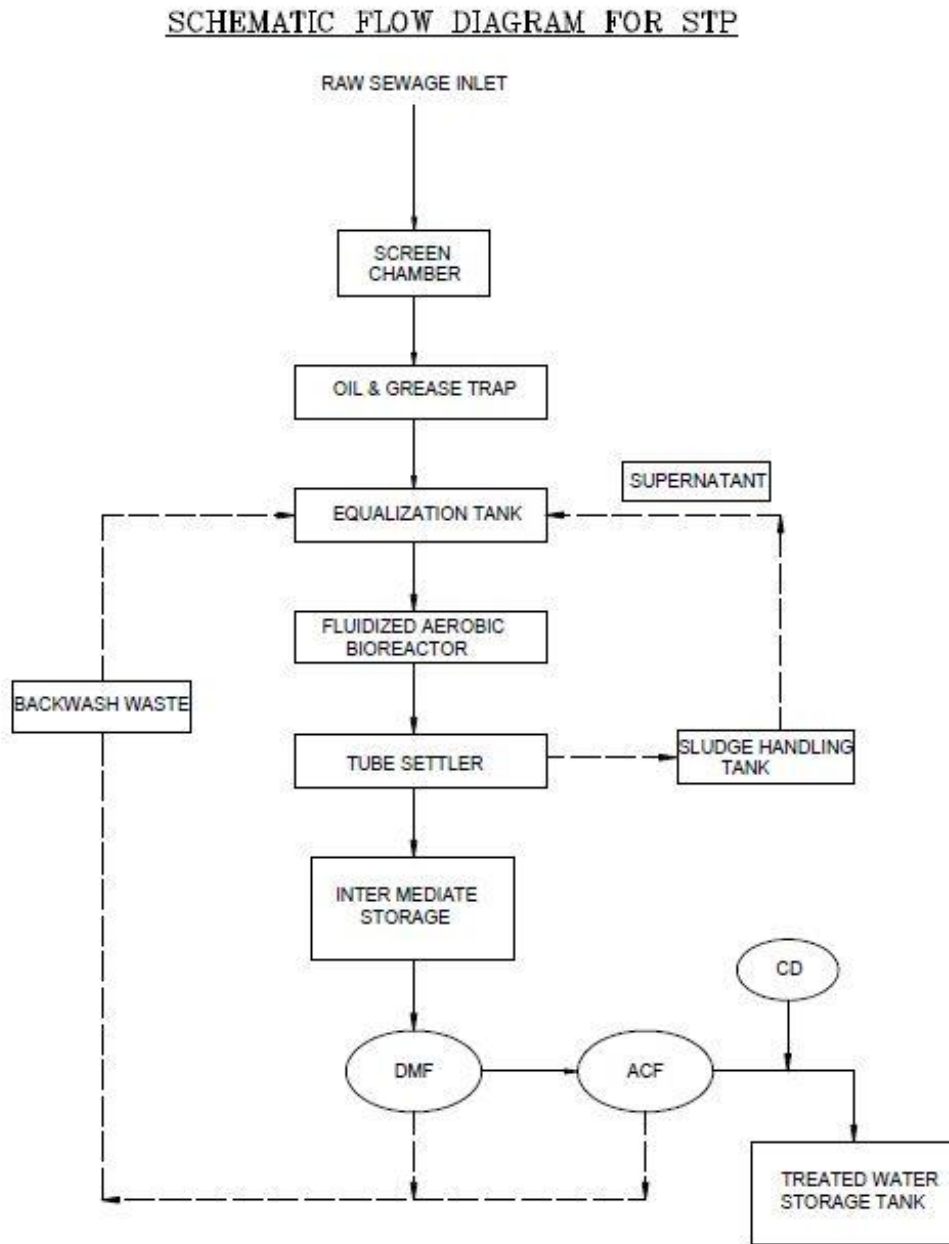
Source: DPR, 2016

Figure 3.7 Industrial Wastewater Treatment System Flow Diagram



Source: NBBL

Figure 3.8 Schematic Diagram of Sewage Treatment Plant



Source: NBBL



### 3.6.4 *Materials Storage and Handling*

The plant operation will require chemicals for water treatment and process requirements. A list of the hazardous chemicals which will be used in the Plant and the maximum quantity stored is presented in *Table 3.7*.<sup>1</sup>

*Table 3.7 Chemicals and Storage Capacity*

S. No.	Chemical Name	Maximum Storage Quantity
1.	Hydrochloric Acid	20 m <sup>3</sup>
2.	Caustic Lye	20 m <sup>3</sup>
3.	Sulphuric Acid	20 m <sup>3</sup>
4.	Chlorine	Storage is not required. It comes in cylinders which will be replaced when required
5.	Lube Oil	900 L
6.	HSD	16,000 m <sup>3</sup>

*Source: DPR 2016*

Acids and other hazardous materials will be stored in a dedicated room with adequate ventilation, at the water treatment plant area. HSD will be stored in three tanks with capacity equivalent to 15 days operation on HSD. The storage arrangements for all chemicals will include secondary containment for spillage control. HSD will also be stored in above ground oil tanks (refer to *Figure 3.4* and *Figure 3.5* for fuel oil pump house and tank farm details).

### 3.6.5 *In-house Laboratory*

The Project will be having an In-house Laboratory for quality control as well as for testing and monitoring of quality of the intake water, treated water and discharge water. In addition to that the stack emissions will be directly being monitored through the Continuous Emission Monitoring System (CEMS) and the emissions will be monitored by the Plant Control Room. The portable instrument for the noise testing will be provided for the plant noise monitoring. All the monitoring, testing and analysis will be carried out by trained technicians.

Furthermore, the project will engage recognized third party monitoring agency for periodic monitoring of stack emissions, ambient air quality, water quality and noise (plant noise and ambient noise) monitoring and analysis, as per the proposed environmental monitoring programme for operation phase as well as based on the recommendations of the DoE.

### 3.6.6 *Manpower Requirement*

During the construction phase, the engineering, procurement and construction (EPC) company will be responsible for overall construction and

<sup>1</sup>Hazardous or toxic materials/waste shall not be imported as raw material for industry.

commissioning. However, NBBL will also have the following manpower for supervision of the construction and commissioning activities:

• Project Director	:	01
• Resident Construction Manager	:	01
• Planning & MIS	:	02
• Civil & Structural Works	:	03
• Mechanical	:	04
• Electrical and CI	:	03
• HR & Admin	:	01
• Quality	:	02
• Safety	:	01
• Store	:	01
• F&A	:	01
• <b>Total</b>	:	<b>20</b>

*Note: Construction work shall be carried out by EPC contractor and supervision shall be done through a Project Management Consultant. In totality approximately 1500 (Peak) personnel shall be engaged through subcontracts.*

The construction phase will also involve a workforce of approx. 1500(Peak) workers, a majority of which are likely to migrant from other parts of Bangladesh or outside of Bangladesh depending upon the choice of sub-contractors.

The proposed organisation chart of NBBL for the project execution is presented in *Figure 3.9*.

During the operation phase, following manpower will be engaged:

• Plant Manager	:	01
• Administration	:	05
• Operations	:	24
• Maintenance	:	16
• Warehouse	:	03
• Environment & Safety	:	02
• <b>Total</b>	:	<b>51</b>

Contractors will be employed for other services like: plant overhaul, housekeeping, canteen, security service, staff transportation, etc. In addition, there are likely to be approx. 70contract workers.

The proposed organization chart for the Plant O&M is presented in *Figure 3.10*.

Figure 3.9 Proposed Organisation Structure of NBBL during Project Construction

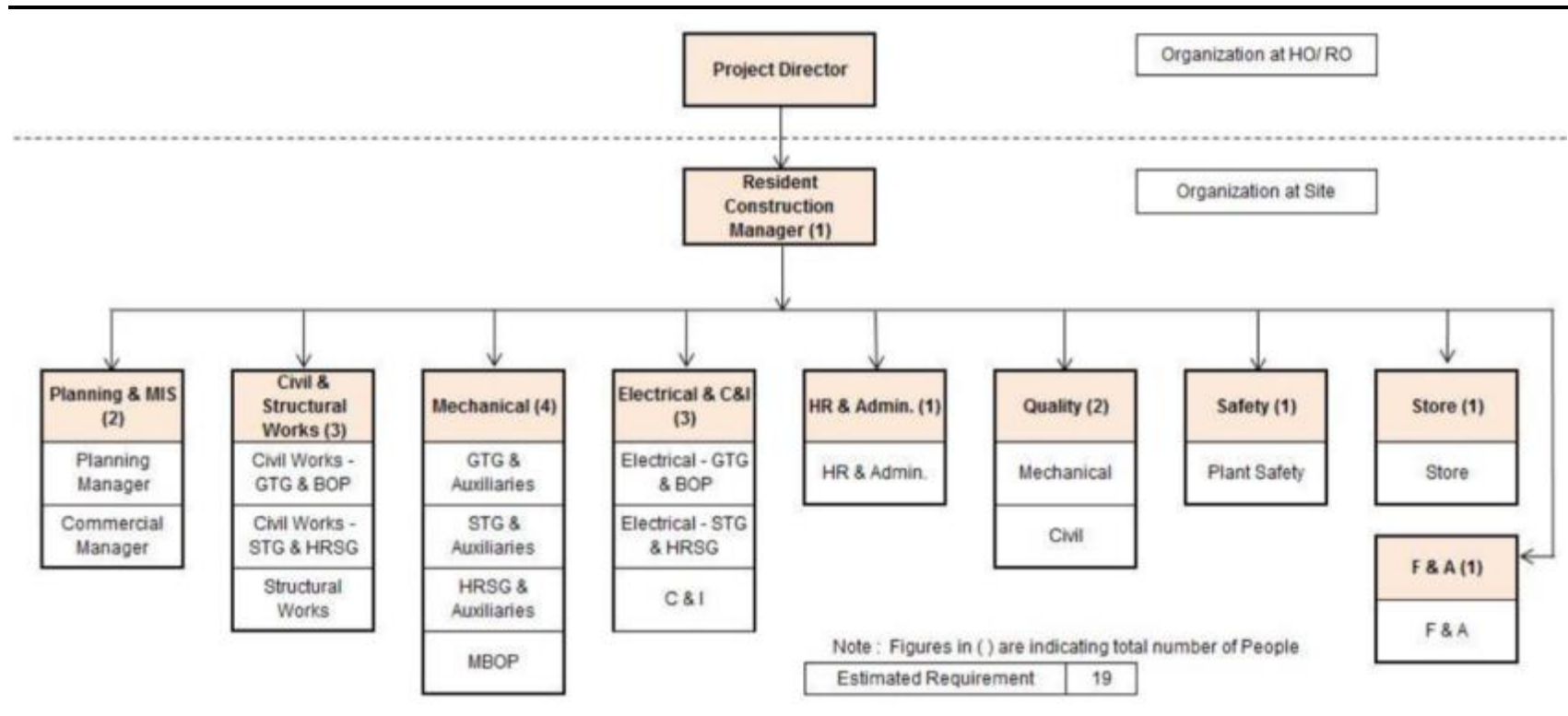
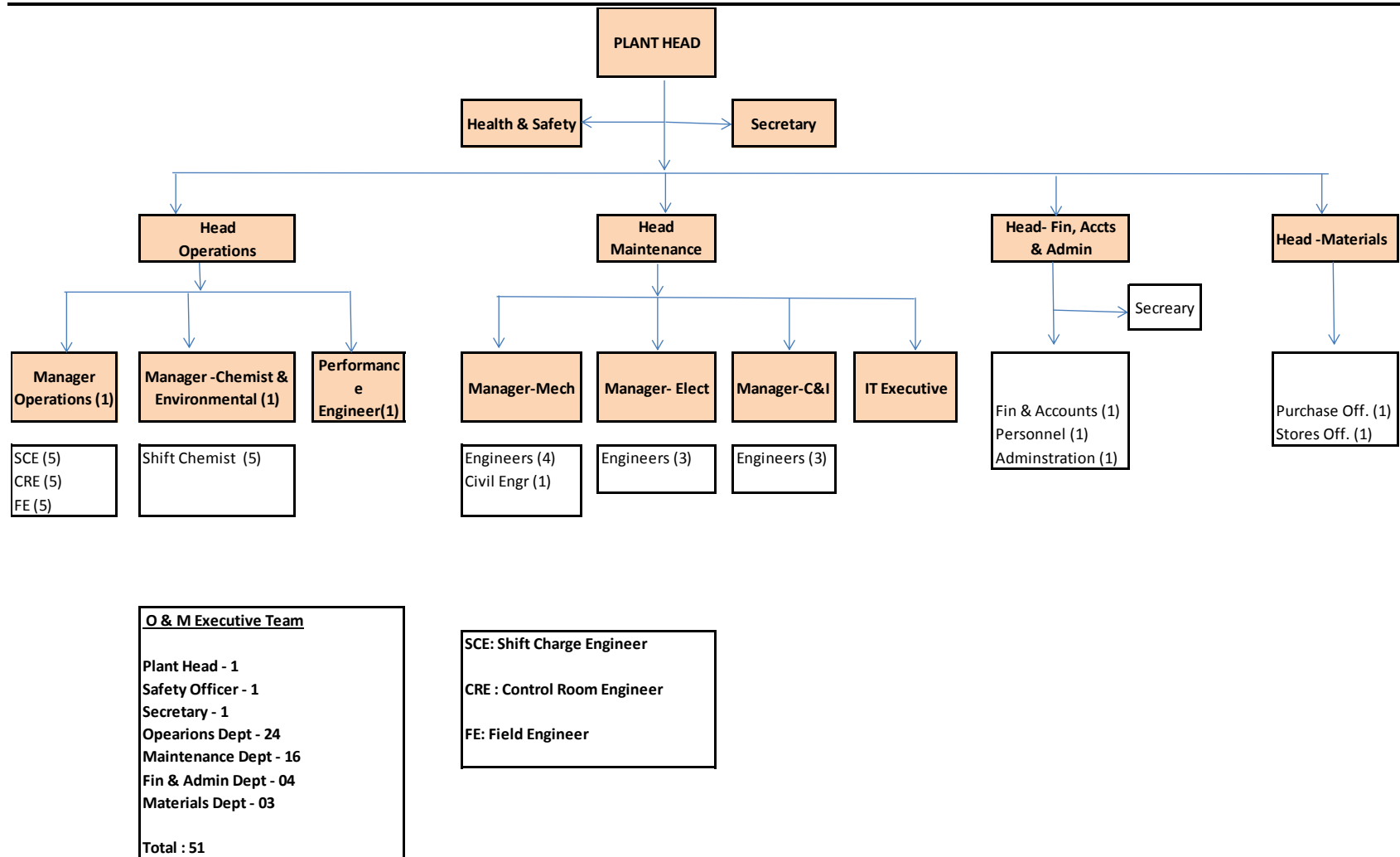


Figure 3.10 Proposed Operation and Maintenance Organization Chart



Source:DPR 2016

### 3.7 SAFETY PROVISIONS

#### 3.7.1 Fire Fighting System

For protection of the plant against fire, all plant will be protected by any one or a combination of the following systems:

- Hydrant system (also includes the required number of hydrant pumps electrical motor driven and diesel engine driven).
- Automatic high velocity and medium velocity sprinkler system.
- Portable and mobile chemical extinguishers.
- Inert gas system
- Fire detection and alarm system
- Fire Tender

Clarified water as supplied to the plant will be used for fire-fighting purposes. Dedicated firewater storage of two hours' fire-fighting requirement, will be maintained in the Clarified Water Reservoir itself for fire-fighting purpose. The system will be designed as per the applicable Codes and Standards of National Fire Prevention Association (NFPA), USA. Regulations of local statutory authority as applicable will also be followed.

#### 3.7.2 Grounding

A grounding system designed for a fault level of 50 kA will be provided and designed in accordance with the IS/IEEE-80 standards to meet the requirements of safety and protective relaying. The earthing system will consist of MS rods for buried applications and GI flats for exposed earthing connections.

#### 3.7.3 Lightning Protection

A lightning protection system for the Plant designed to satisfy the requirements of IS/BS-6651-1991 and IEEE 142-1991 standards will be provided in the Plant.

#### 3.7.4 Underground Gas Pipeline Protection

The gas supplier will design, construct, install, commission and test the gas pipeline as per specification spelled in GSA. The separation of this pipeline to the existing natural gas pipeline of Bhola-I CCPP will be maintained as per **Gas Safety Rule 1991 and its amendment (2003) of Bangladesh**. It will be gas supplier's property as part of the gas supply network during our plant operation. Cathodic protection will be in place for the buried section of the pipeline and the design will be based on soil resistivity .

*Construction Phase*

The Plant will be constructed, installed and commissioned and be operable and maintainable in full compliance with relevant health and safety requirements, all related acts, regulations, codes and statutory requirements of the Laws of Bangladesh.

The Construction Contractor will submit a Health and Safety Plan prior to commencing work on the Site.

The Health and Safety Plan will have method statements, which will include, but not be limited to, working methods, plant utilisation, construction sequence and safety arrangements. The Contractor's key duties will be to:

- develop and implement the Health and Safety Plan, including rules for management of the construction work;
- ensure that Sub-Contractors and workers comply with the health and safety plan;
- monitor the health and safety performance of Sub-Contractors and give directions as appropriate;
- arrange for competent and adequately resourced Sub-Contractors to carry out the work safely where it is subcontracted;
- ensure the co-ordination and co-operation of Sub-Contractors;
- obtain from Sub-Contractors the main findings of their risk assessments, the steps to be taken to control and manage the risks, including method statements for all aspects of the work;
- ensure that Sub-Contractors and workers have information about risks on Site and that there are co-ordinated arrangements for workers to discuss health and safety and offer advice to the Contractor;
- ensure that all workers are properly informed, consulted and trained on health and safety issues;
- ensure that only authorised people are allowed onto the Site; and
- pass information to the Employer for the health and safety file.

EPC contractor of NBBL will comply with requirements of certified systems for quality, environment and occupational health and safety of SP EPC. Copy of these is presented in *Figure 3.11*. A brief profile of the EPC contractor is presented in *Annex L*.

**Figure 3.11** *Environment, Occupational Health & Safety and Quality Management System Certification of the EPC Contractor*



Source: NBBL

### *Operation Phase*

The Company will implement an international standard environment, health and safety (EHS) program in the Plant, which will be in full compliance with relevant health and safety requirements, all related acts, regulations, codes and statutory requirements of the Laws of Bangladesh and of the World Bank. In addition, the Plant aims to be certified to OHSAS and ISO 14001 within 2 years of operation.

An offsite accident and emergency response plan to control and mitigate the effects of any catastrophic incidents in above ground installations (AGI) or underground installation (UGI) or road transportation will also be prepared by the project in consultation with the district administration. The offsite emergencies will also be communicated to the local people.

## **3.8 ANALYSIS OF ALTERNATIVES**

The Project has considered alternatives in terms of site location, design and technology options. An analysis of these alternatives has been undertaken for the proposed Project including consideration of a no-Project scenario.

### **3.8.1 No-Project Scenario**

The generation and supply of electricity has a significant impact on the national economy of any country. Presently, 68% of the total population has access to electricity and per capita generation is 348 kWh, which is significantly lower than other developing countries (Power Division 2015).<sup>1</sup> The total installed capacity of power plants in Bangladesh as of January 2017 is 13,151 MW, which includes 600 MW of imported power.<sup>2</sup>

<sup>1</sup> The neighbouring country India was having per-capita energy consumption in 2007-08 as 704.2 kWh ([www.cea.nic.in](http://www.cea.nic.in)), which in January 2012 is reported as 776 kWh per annum (The Wall Street Journal, January 3, 2012).

<sup>2</sup> [www.bpdb.gov.bd](http://www.bpdb.gov.bd) (website of Bangladesh Power Development Board)

In the public sector a number of the generation units have become very old and have been operating at much reduced capacities. As a result, their reliability and productivity has been poor. For the last few years actual electricity demand in the country has not been met due to a shortage of available generation capacity. In addition, due to a shortage of gas supply, some power plants are unable to reach their full generation capability.

The current supply-demand in Bangladesh also has a knock on effect on all other key sectors including agriculture, industry, commercial and domestic sectors. There is therefore no alternative to adding more power generating units to the existing power system of Bangladesh, to help improve and meet the energy demand for both domestic and industrial requirements.

The 'No Project Scenario' is also likely to have a negative effect on opportunities for employment, both directly from the proposed power project and its dependant sectors such as agriculture, industries and manufacturing that require stable power supply in order to operate and be competitive.

The electricity produced from the power plants are supplied to the distribution grid and GoB decides on the areas to which the power generated is to be supplied. So, though the power plant will be at Bhola, the local community in Project AOI may or may not benefit from the power generated. Therefore another perspective of the 'No Project Scenario' is whilst the country as a whole will benefit from power; the local area may get subjected to a disproportional impact vs the benefit to the whole nation.

### 3.8.2

#### *With Project Scenario*

##### *Site Location*

The proposed site including Bhola I project site was acquired by BPDB in early 2000 to develop a power generation complex in order to utilise the natural gas available from the Shahbazpur Gas Field. BPDB has already constructed one 225 MW CCPP (Bhola I) at this complex. As per the master plan of the complex, space provision for one more power plant with capacity of 225 MW CCPP (Bhola II) has been made. Power would be available at 230 kV level in the Existing 230 kV outdoor switchyard and would be fed to PGCB grid through existing transmission lines to Barisal sub-station. The Natural Gas for the Power Plant will be supplied from gas line of Sundarban Gas Company Ltd. from Shabazpur gas field which is at a distance of 6 km from the power plant site. Pipeline will be laid for this purpose.

Based on the information available from PetroBangla, available gas quantity in Shahbazpur Gas Field is approximately 0.371 trillion cubic feet (tcf), which is sufficient to run Bhola-I and Bhola-II power plants on natural gas as fuel for 14 years considering 35 mmscfd fuel requirement of each plant. SGCL is currently having four wells (1, 2, 3 and 4) out of which 3 wells (1, 3 and 4) are functional. At present average production from Shahbazpur Gas Field is about



38 mmscfd, out of which 99% is being utilised for power generation and the current production is only from 2 operating wells due to lesser demand. Considering that the natural gas availability for running both the plants upto PPA period, the Project (Bhola-II) is planned to utilise natural gas as primary fuel and HSD as secondary fuel.

Considering the advantages of the present location described below, as well as the limited footprint and impacts, no alternative site location has been considered for the Project. The site for the Project offers following advantages:

#### Technical

- Adequate area available for 225 MW dual fuel fired power plant and associated facilities;
- Proximity to Sundarban Gas Company Ltd Valve Station and small gas pipeline length required, (~ 6.0 km);
- Access to road and nearby water transportation networks;
- Available water supply source for process including cooling water;

#### Geological

- Geologically stable, low earthquake risks; and
- Developed land with elevation above the highest flood level;
- Away from coast line;

#### Social and Environmental

- No major sensitive environmental receptors ( such as communities, hospitals, schools, etc.) in close proximity;
- No physical cultural resources on site and in close proximity (~500 m);
- No resettlement requirements.

#### Design

##### CCPP Configuration

Alternative 1: The CCPP module consisting of 1 Gas turbine, 1 Heat Recovery Steam Generators (HRSG) and one Steam Turbine using steam from the HRSG. This is known as 1+1+1 configuration of the CCPP module, based on the numbers of gas turbines, HRSGs and Steam Turbines in the module.

Alternative 2: One module consisting of 2 Gas turbines, 2 Heat Recovery Steam Generators (HRSG) connected to each gas turbine, and one common Steam Turbine using steam from both the HRSGs. This is known as 2+2+1 configuration of the CCPP module.

Considering that the existing Bhola I power plant utilizes a 2+2+1 configuration using GE 6FA gas turbines, analogous configuration using GE 6F.03 gas turbines, is selected for this Bhola II project. The GE 6FA gas turbines include an 18-stage axial compressor and a three stage turbine and a cool-end drive and axial exhaust, which is beneficial for combined cycle

arrangements. The turbine also provides flexibility in cycle configuration and fuel selection and therefore is selected for dual-fuel operations of the plant. This turbine also having dry low NO<sub>x</sub> combustor systems to meet the stringent environmental emission requirements applicable at present.

#### Alternative Cooling Options

Two options available for cooling are once through cooling system and induced draft cooling tower. Construction of a cooling tower will have cost implications, but it will reduce the water requirement for the Project as well as limit the quantity of warm water discharge from the project. Once through cooling system will require about 16,000 m<sup>3</sup>/hr of cooling water, whereas induced draft cooling system will require only 320 m<sup>3</sup>/hr for cooling tower make-up, which is only 2% of the once through cooling water demand.

Adverse environmental and social impacts of cooling tower with respect to once through cooling system are limited and therefore, induced draft cooling tower has been considered in the Project design. This will also help in reducing the raw water requirement of the plant significantly.

#### Alternative Fuel Options

As mentioned earlier, the present natural gas availability from the Shahbazpur Gas Field operated by SGCL is not sufficient to run both Bhola-I and Bhola-II plants using natural gas as fuel for the entire duration of the PPAs. Based on the proven reserves of this gas field, the two plants can run with natural gas upto a period of 14 years. Since Bhola-I project is designed only for natural gas as fuel and there is no provision of any alternate fuel, therefore, Bhola-II project has been conceptualised as dual fuel and alternate fuel for the project is HSD (with maximum sulphur content of 0.25%), which is cleaner fuel in comparison to HFO (with maximum sulphur content of 3.50%), as per the Bangladesh Petroleum Corporation (BPC) fuel specifications.

### 3.8.3

#### **Conclusion**

The 'No Project Scenario' is likely to have a negative effect on opportunities for employment, both directly from the proposed power project and its dependant sectors such as agriculture, industries and manufacturing that require stable power supply in order to operate effectively and be competitive. This will further affect the proposed industrial development in the Bhola District.

The site location is well suited for setting up of power plant with availability of adequate availability of land, water, access to road, and waterways, fuel source/supply arrangement. Associated facilities, such as, water intake and abstraction mechanism, pump house location, construction laydown and camp areas have also been selected based on the basis of alternative analysis and selection of best suited option.

The project design has considered embedded pollution control systems, which include NOx control, stack height for dispersion of pollutants, use of cleaner primary fuel (natural gas), use of Dehular Canal water for the Project as opposed to ground water, induced draft cooling tower for reducing water requirement and no direct discharge of cooling water into Dehular Khal.

Best suited technological options have been considered by NBBL and the dual fuel system has been selected to provide more reliability of power generation.

To conclude, many of the alternatives as site location, gross capacity, fuel options were not directly under purview of NBBL as the proposed project will be implemented through a IPP model. Within the available alternatives, NBBL has opted for best suited technological option for power generation.

#### 4.1 THE ENVIRONMENTAL BASELINE

The baseline conditions define the physical and biological conditions that prevail in the Project Study Area. It includes information on receptors and resources that were identified during the scoping stage of the Impact Assessment process as having the potential to be affected by the Project, as well as have an impact on the sustainability of the Project.

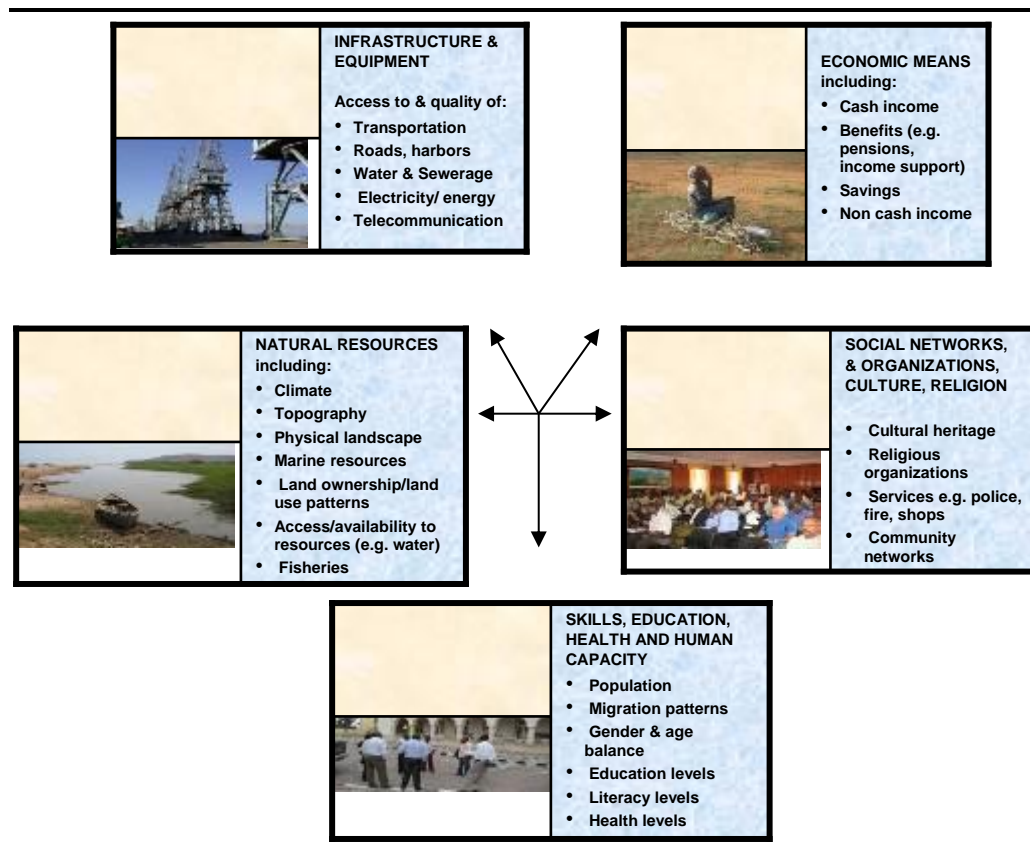
This section describes the environmental baseline conditions in the Study Area (defined below). The analytical framework for the impact assessment is based on the sustainable livelihoods framework<sup>(1)</sup>, which focuses on putting people at the center of development (refer *Figure 4.1*). The baseline therefore describes the interrelated resources and receptors, which in the livelihoods framework are termed 'capital'. The five broad areas of resource and receptors on which livelihood depends are as follows:

- **Natural Capital** – natural resource stocks, which include *physical* (e.g. climate topography, land use), *terrestrial* (e.g. flora, fauna), and *aquatic* (e.g. benthos, fisheries);

The baseline studies were carried over a period of two months from April to May 2016 (air, noise, soil, sediment, water, traffic, terrestrial and aquatic ecology) and additional field surveys and consultations in January 2017. Reference has also been included to secondary sources.

(1) "A livelihood comprises the capabilities, assets (including both material and social resources) and activities required for a means of living. A livelihood is sustained when it can cope with and recover from stresses and shocks and maintain or enhance its capabilities and assets both now and in the future, while not undermining the natural resource base." (UK Department for International Development - DFID)

Figure 4.1 Resources and Receptors as per Sustainable Livelihoods Framework



#### 4.1.1 Project Site

The Project site is located in Kutba Union of Burhanuddin Upazilla in Bhola District of Bangladesh. The detail of the Project location along with site surroundings has been discussed in *Section 3.2* and *Section 3.3*.

#### 4.1.2 Area of Influence

The Area of Influence (AOI) of the Project comprises of the Project Site and the surrounding area, where influence of the Project activities is anticipated. The areas likely to be affected by the Project and its associated activities may include:

- the project activities and facilities that are directly owned, operated or managed by the project proponent (including by contractors) and that are components of the project, such as the power plant, gas pipeline, water pipelines and transmission line to the power grid sub-station;
- impacts from unplanned but predictable developments caused by the project that may occur later or at a related location such as increase in traffic on the approach road;
- impacts on biodiversity or on ecosystem services upon which affected communities' livelihoods are dependent;
- associated facilities, that are not funded as part of the project and that would not have been constructed or expanded if the project did not exist and without which the project would not be viable; and

- cumulative impacts that result from the incremental impact, on areas or resources used or directly impacted by the project, from other existing, planned or reasonably defined developments at the time the risks and impacts identification process is conducted i.e. existing Bhola-I CCPP, proposed Bhola-II CCPP in the surroundings<sup>1</sup>.

Further to this, the AOI with respect to the environmental and social resources was considered based on the following reach<sup>2</sup> of impacts:

#### *Air Quality*

- Gaseous pollutants (e.g. NO<sub>x</sub> and SO<sub>2</sub>) and fine particulate matter (PM<sub>10</sub> and PM<sub>2.5</sub>)-typically up to 2-2.5 km from operations;<sup>3</sup>
- Cumulative impact of air pollutants emission from Bhola 1 and 2 projects; and
- Dust fall -typically up to 200 m from construction activities.

#### *Noise*

- Noise impact area (defined as the area over which an increase in environmental noise levels due to the project can be detected) -typically 500 m from operations and 100 m from the access roads; and
- Cumulative impact of noise generation from Bhola I and Bhola II projects

#### *Water*

- Surface water body -typically 200 - 500 m upstream and downstream of water intake point and within 500 - 700 m upstream and downstream of discharge point.
- Other Surface water bodies within 2-2.5 km of the project footprint
- Ground water in 1-2 km radius of project footprint.

#### *Flora and Fauna (Terrestrial and Aquatic)*

- The direct footprint of the project comprising the project site.
- The areas immediately adjacent to the project footprint within which a zone of ecological disturbance is created through increased dust, human presence and project related activities (e.g., trampling, water intake/outfall, transportation). This kind of disturbance has been estimated to occur within the project footprint and surrounding areas of about 500 m to 1 km from the activity areas.

Based on the above the AOI for environmental studies was limited to 5 km from the Project site. However, as per DoE guidelines for the study area of 10 km has been considered in this study, with focus on immediate vicinity of the Project site.

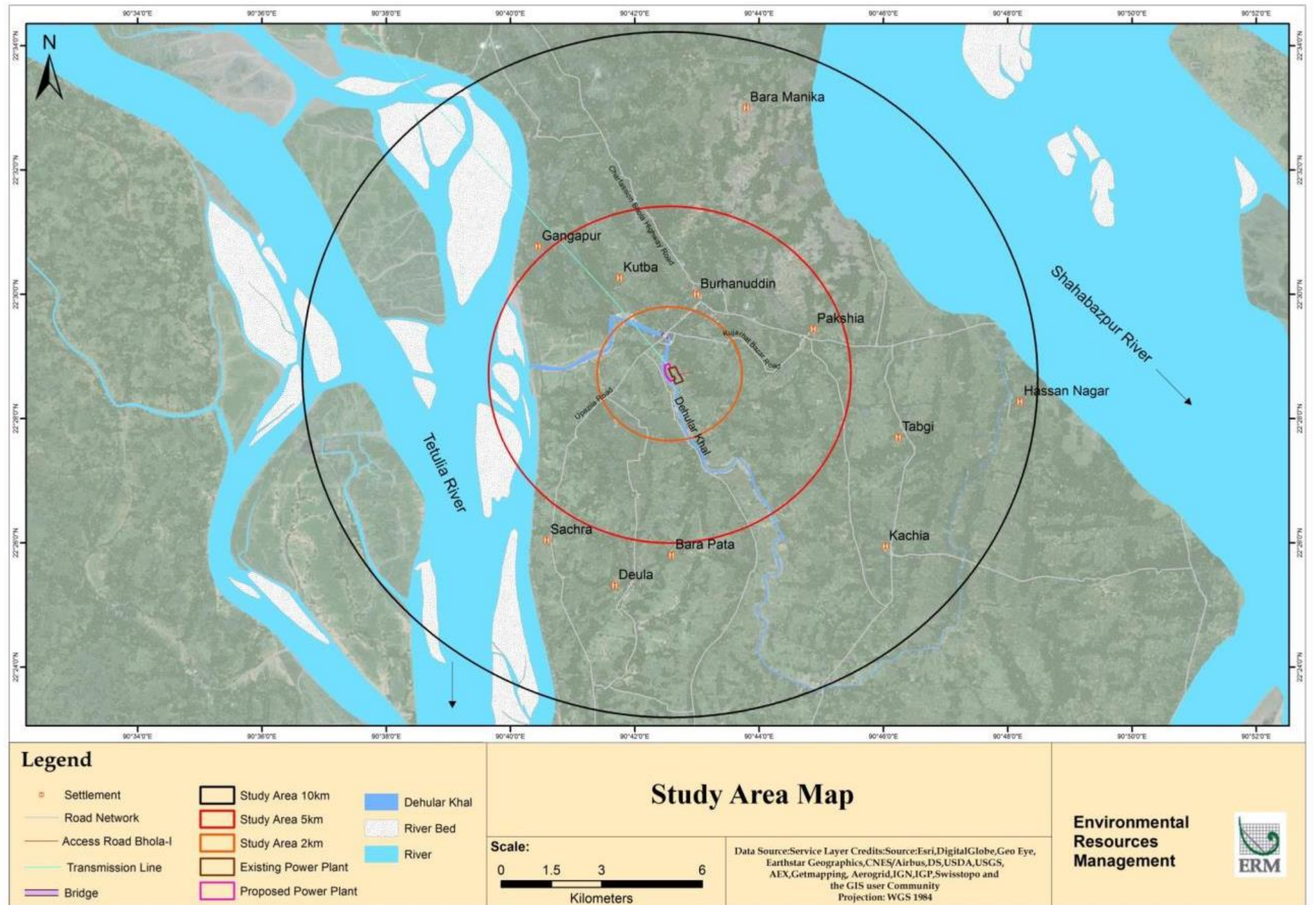
<sup>1</sup> At present, no other planned industrial development is known in the proximity of the Project site.

<sup>2</sup> Distance based on ERM's experience with similar projects

<sup>3</sup> The air quality dispersion modelling results also indicated that the maximum ground level concentration in all cases will occur between 1.5 to 2.0 km from the project site.



Figure 4.2 AOI at 10 Km from the Project Site with Receptors Locations



Source: Based on Satellite Imageries, field surveys, Local GIS and LGED maps.

The primary objective of the environmental and social baseline study is to provide a baseline against which potential impacts from the construction, operational and decommissioning phases of the Project can be assessed. The methodology adopted for collecting the baseline data is as follows:

- Reconnaissance survey for scoping was carried out in March 2016 for the current study. The detailed environmental and ecological field monitoring and survey was carried out during the period of April and May 2016;
- Study area of 5 km radial zone from the centre of the proposed Project location was selected for the baseline studies considering the location of project components, associated components and nature of project activities;
- Primary environmental data collection was through monitoring and field survey for water, air, soil, sediment, noise, traffic and ecology;
- Secondary data was collected from government reports, academic institutes, websites, published literature, interactions with government department and stakeholders etc.

Land use/cover inventories are an essential component in land resource evaluation and environmental studies due to the changing nature of land use patterns in the study area. The land use study for the proposed power plant and area within its 10 km buffer was undertaken with the following objectives:

- To study the land use/cover in the 10 km radius area of the proposed power plant site and provide inputs for environmental planning of the proposed plant by analysing the existing land use/land cover scenario;
- To establish the existing land use scenario using a GIS database for incorporation of thematic information on the different physical features including drainage and water bodies, settlements, transport networks and administrative boundaries etc.
- To identify and map waterbodies, drainage and the streams in the study area.

#### *Methodology*

In the present study, for delineation and analysis of land use / land cover, cloud free multi-temporal Satellite Imagery of IRS LISS- IV RESOURCESAT-2 (Path/Row: 110/056 A; DOP: 01-JAN-2016) has been used. The details of the scenes, multi-spectral bands, spectral and spatial resolutions and date of pass are given in *Table 4.1*. Land use classification was however analysed using the individual multi-spectral scenes only.



All the data sets were processed using the ARC GIS software (version 10.3.1). All vectors are prepared with the following projection parameters:

- Projection Type: Universal Transverse Mercator (UTM)
- Spheroid Name: WGS 84
- Datum: WGS 84
- Zone: 46N

The area has good coverage of homestead vegetation which shows great mixing in digital classification. For better accuracy, land use / cover analysis was carried out using on screen visual interpretation technique. Different landuse classes were digitized as vector layer keeping the imagery on the back drop. These landuse vectors were stored separately, corrected topologically and assigned codes for individual landuse class. Area calculation done using the calculate geometry tool.

**Table 4.1** *Details of Satellite Data used in the Study*

Satellite and Sensor	Orbit/row	Date of Pass	Spatial Resolution (meters)	No. of bands and Band width (Microns)
LISS-IV	024396	01.01.2016	5.8	G : 0.52 – 0.59 R : 0.62 – 0.68 NIR : 0.77 – 0.86

*Landuse Interpretation of the Study Area*

The predominant land use-land cover of the study area includes homestead plantation & vegetation (33.27%) and agriculture land (31.65%). This is followed by river (20.40%), mudflat (11.23%). Other category land-use and land cover in the study area includes industry, settlement, bricklin, waterbody, road, etc. The land use of the study area is presented in **Table 4.2** and **Figure 4.3**.

**Table 4.2** *Land Use and Land Cover of Study Area*

Land Use/ Land Cover Category	Area (sq. km)	Percentage
Agriculture	102.64	31.65%
Brick-klin	0.14	0.04%
Dehular Khal	1.42	0.44%
Homestead Plantation & Vegetation	107.89	33.27%
Industry	0.18	0.05%
Mangrove	7.47	2.30%
Mudflat	36.41	11.23%
Rivers	66.15	20.40%
Road Network	0.75	0.23%
Settlement	0.98	0.30%
Waterbody	0.23	0.07%
<b>Total</b>	<b>324.26</b>	<b>100.00%</b>

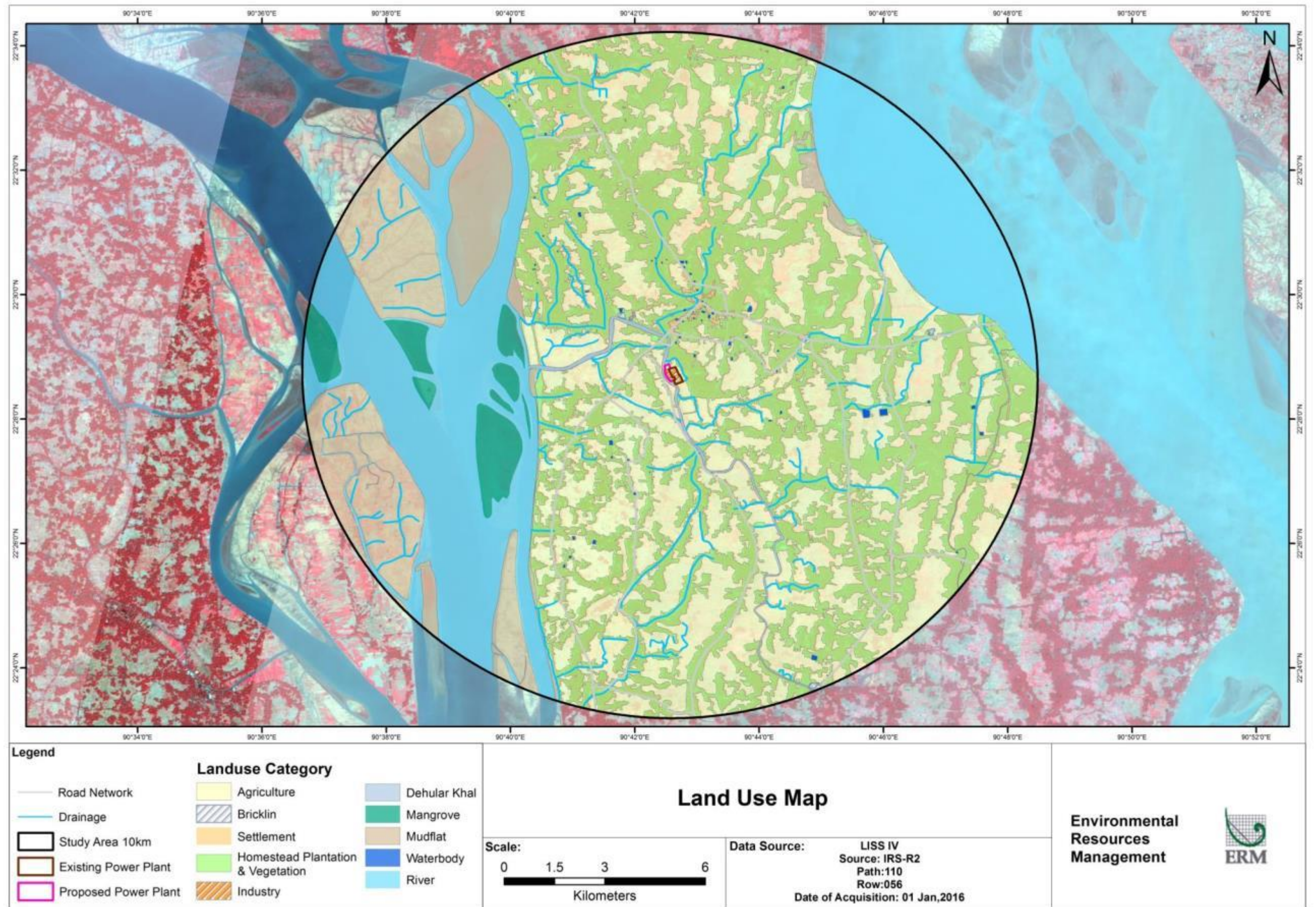
*Note: Homestead plantation is one of the most important classes of the study area. Like other rural areas this also covered with lots of homestead plantations with high Normalized Difference Vegetation Index (NDVI) variability (high diversity/ vegetation vigour).*

As interpreted from *Table 4.2*, the following can be concluded about the landuse/land cover of the study area:

- The maximum percentage of land use/land cover of the study area (33.27%) falls under homestead plantation and vegetation cover followed by agricultural land (31.65%) and water bodies (20.91 %).
- The economic activity in the area is prominently agricultural-based, which also reflects in large percentage of agricultural land and homestead plantation.
- Inland waterways are also commonly visible within the study extents which are used for navigation.
- Mudflats cover 11.23% of total geographical area of the study area.
- Major rivers in the study area are Tentulia and Meghna rivers bounding the area from western and eastern sides respectively.
- It should be mentioned that due to the extent and canopy density of homestead plantations the settlements are not visible properly in the satellite imageries.
- The only urban built up or mixed built up activities are confined to Burhanuddin Town. All other settlements are predominantly rural.
- No major industrial activities are there within the buffer extent except Bhola-I CCPP, Shahbazzpur Gas Field, some brick kilns and agro-based small industries.



Figure 4.3 Landuse/ Landcover Map of the Project AOI





### 4.3.2

#### *Topography*

A digital elevation model (DEM) or 3-D representation of the terrain surface of 10 km study radius is shown in *Figure 4.4*. The proposed plant location, its 10 km buffer area as well as the other linear features are shown in the Relief maps with the height range.

Contour of the study area are generated from the Advanced Spaceborne Thermal Emission and Reflection Radiometer (ASTER) relief maps. Toposheets were not available for the study area and therefore all the relevant information are extracted from the Shuttle Radar Topography Mission (SRTM) DEM only. All the processing was done in the ARC GIS software.

Contour map derived from DEM shows that the topography of the 10 km study area is predominantly a flat terrain with maximum elevation in the northern part on the bank of Tentulia River. The elevation levels of both the rivers Tentualia and Shabazpur are at the lowest elevation in the range of 0-3 m.

A slope map of the 10 km study radius is represented in *Figure 4.5*. The area has no considerable slope (0-10% predominantly) except in some locations (20-40 % slope covering a very negligible area) comprising of river valley passing through the eastern and western part of the proposed area.

A detailed topographical survey of the project site carried out by the BPDB prior to construction of Bhola-I CCPP, which revealed that the site was having plain terrain and the variation is in the range of 0.944 m only. The site was having gentle slope towards west with highest elevation of 2.77 m above MSL. However, in order to protect the land from any flooding events, same was raised by BPDB prior to construction of Bhola-I CCPP with an average elevation of +4.10 m above MSL and the foundation of critical plant equipment was maintained at a level of +4.80 m above MSL. Embankment was also constructed for flood protection.

Topographic profile of the Project site and immediate surroundings upto 500 m has been presented in *Figure 4.6*.

Figure 4.4 Digital Elevation Map of the 10km Study Area

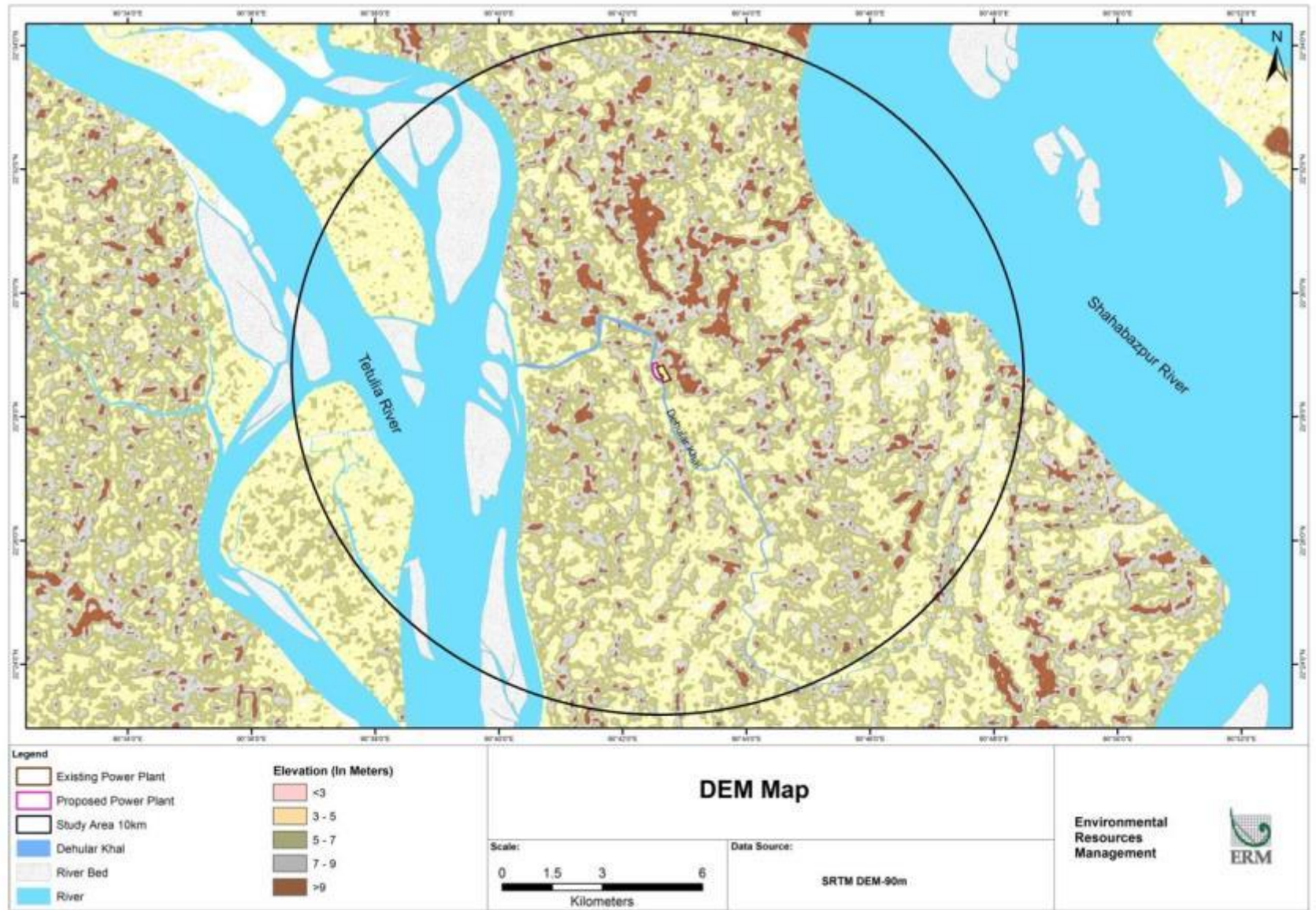


Figure 4.5 Slope Map of Project AOI

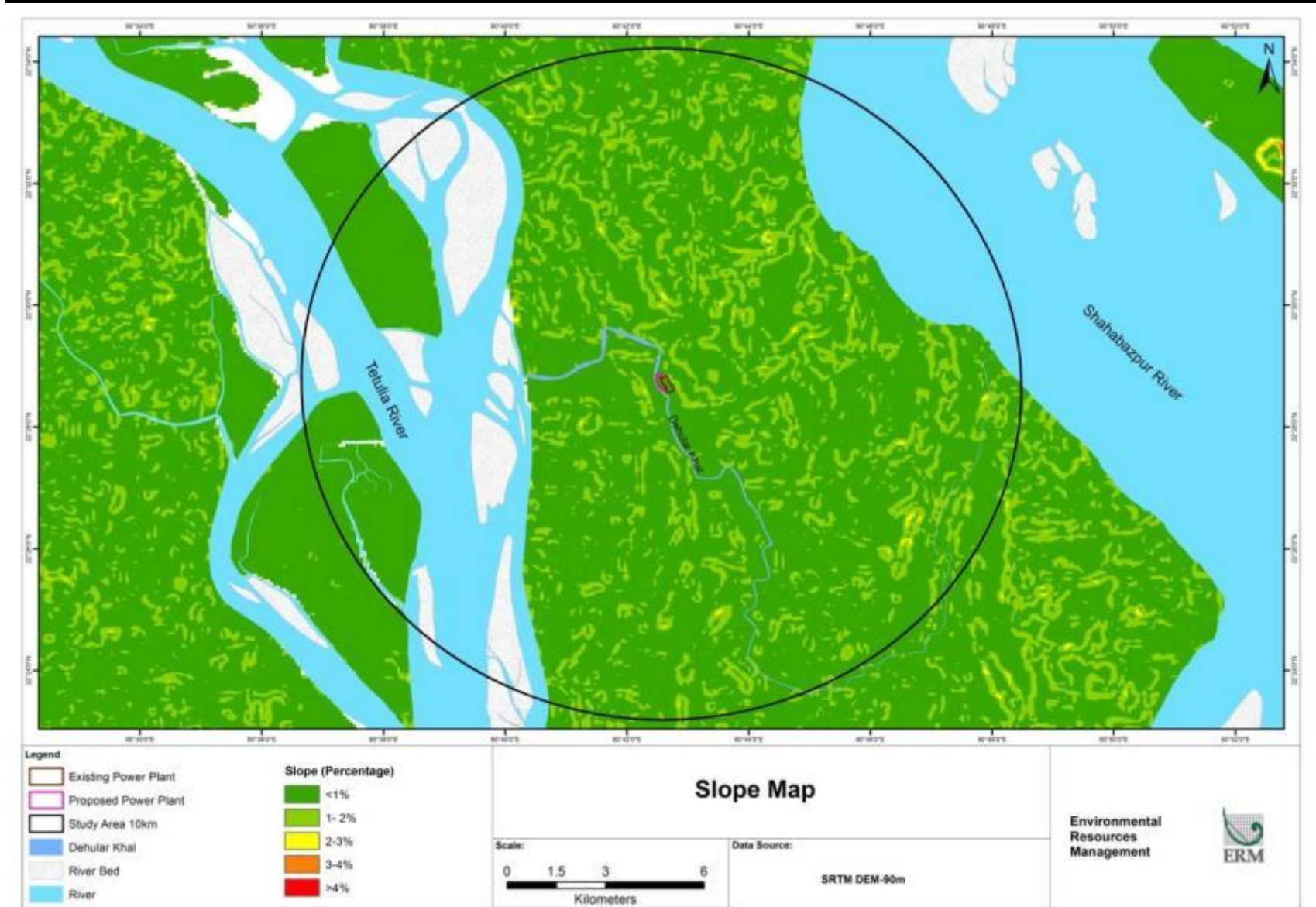
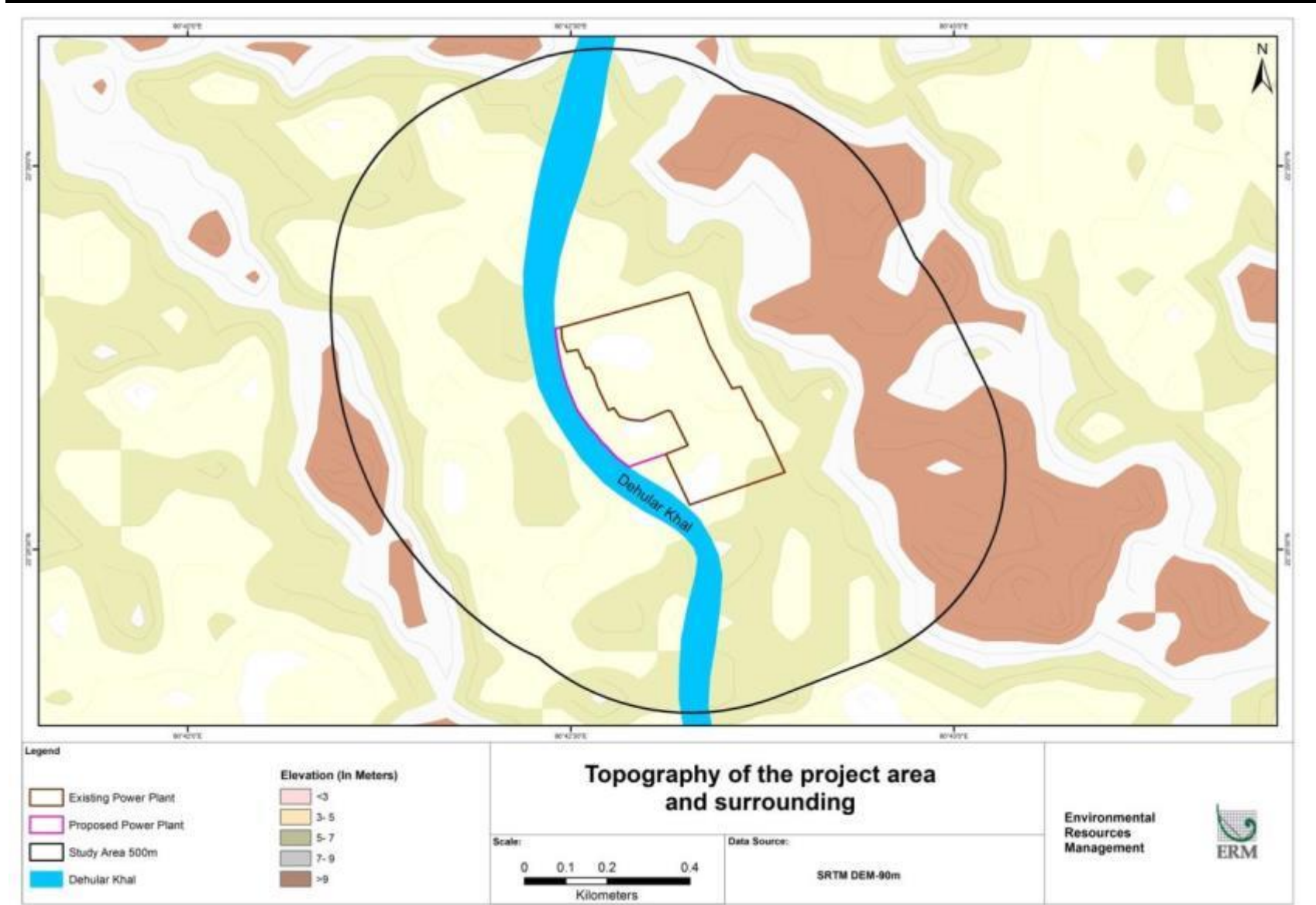




Figure 4.6 Topography of Project Site and immediate surrounding



The geological evolution of Bangladesh is related to the uplift of the Himalayan mountains and outbuilding of deltaic landmass by major river systems having their origin in the uplifted Himalayas. This geology is mostly characterised by the rapid subsidence and filling of a basin in which a huge thickness of deltaic sediments were deposited as a mega delta built out and progressed towards the south. The delta building is still continuing into the present Bay of Bengal and a broad fluvial front of the Ganges-Brahmaputra-Meghna river system gradually follows it from behind.

The geology of Bangladesh mainly falls under the following:

- **Stable Precambrian Platform in the North West-** characterised by limited to moderate thickness of sedimentary rocks above a precambian igneous and metamorphic basement.
- **Geo-Synclinal Basin in the southeast-** characterised by the huge thickness of clastic sedimentary rocks, mostly sandstone and shale of tertiary age. The basin is further subdivided into two parts, ie fold belt in east and a foredeep to the west. As the intensity of the folding decreases towards the west, the fold belts unit merges with the foredeep unit, which is characterised by only mild or no folding. So the sedimentary layers are mostly horizontal to sub-horizontal and free from major tectonic deformation in the foredeep area covering the central part of the basin and this is expressed as river to delta plain topography of the land. The Bhola Island falls under this geological unit.
- **Hing Zone-** is a 25 km wide northeast-southwest zone that separates the Precambrian platform in the northwest from the geosynclinal basin to the south east. It is also known as the Eocene hinge zone.

#### *Geology of Bhola*

Bhola Island is part of the Ganges tidal floodplain (towards north) and the young Meghna estuarine floodplain (towards south) and is an active delta (*Figure 4.7*).

In the Ganges tidal flood plain area, the sediments are mainly non-calcareous clays, but they are silty and slightly calcareous on riverbanks and in a transitional zone in the east adjoining the lower Meghna.

In the young Meghna estuarine floodplain area, new deposition and erosion are constantly taking place on the margins, continuously altering the shape of the land areas. The sediments are deep silts, which are finally stratified and are slightly calcareous. In many, but not all parts, the soil surface becomes saline to varying degrees in the dry season. *Figure 4.8* shows the physiographic units of Bangladesh.

#### *Geology and Subsoil Conditions of the Project Site*

Geotechnical investigations carried out as part of Bhola-I CCPP feasibility study report reveals that:

- In the upper 6.5 m depth clayey silt or silty clay is present;

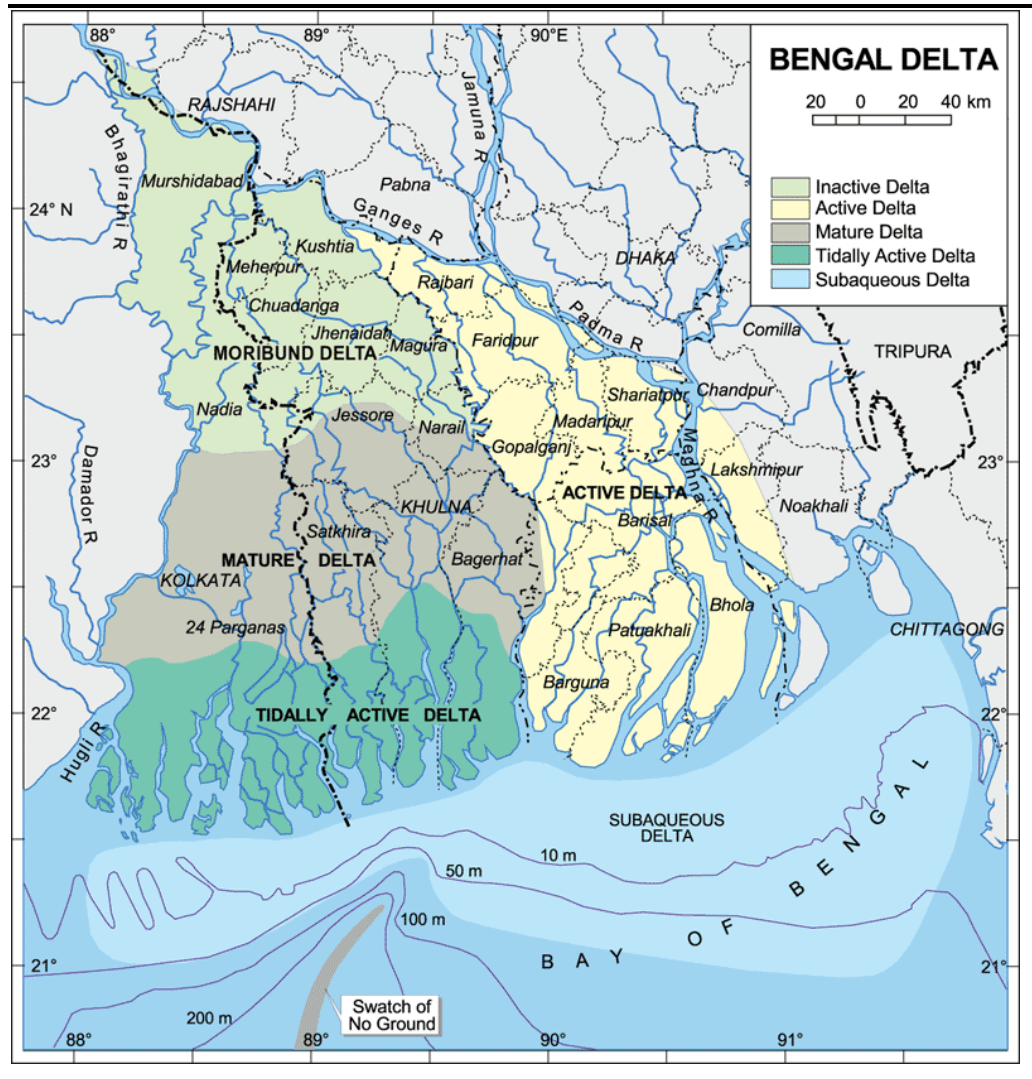


- 6.5 m depth to 15m depth is silty fine sand; and
- Below 15 m fine to medium sand is present.

The details of the Geo-technical Field investigations of the borehole logs sourced from the Feasibility Report indicate the soil stratification at the site is erratic at shallow depths. The investigation results are discussed below:

- **Borehole No. 1**
  - Coordinates: 22°28'42.7"N, 90°42'35.4" E
  - Depth =24.32 m
  - The sandy layers are characterised as grey, loose to medium dense, fine grained sand. It comprises some clay/silt contents at the upper levels which reduce to only traces of silt towards the end depth. Ground water table was zero inches because water was just at the surface.
- **Borehole No.2**
  - Coordinates: 22°28'40.7"N, 90°42'34.4' E
  - Depth = 25 m
  - The sandy layers are characterised as grey, loose to medium dense, fine grained sand. It comprises some clay/silt contents at the upper levels which reduce to only traces of silt towards the end depth. Ground water table was 2 inches above as water was standing in the fields.
- **Borehole No.3**
  - Coordinates: 22°28'40.7"N, 90°42'32.5' E
  - Depth = 18.5 m
  - The sandy layers are characterised as grey, loose to medium dense, fine grained sand. It comprises some silt contents at the upper levels which reduce to little silt towards the end depth. Ground water table was 2 inches above as water was standing in the fields.
- **Borehole No. 4**
  - Coordinates: 22°38'41.5"N, 90°42'42.2' E
  - Depth = 22 m
  - The sandy layers are characterised as grey, loose to medium dense, fine grained sand. It comprises some silt contents at the upper levels which reduce to little silt towards the end depth. Ground water table was 2 inches above as water was standing in the fields.

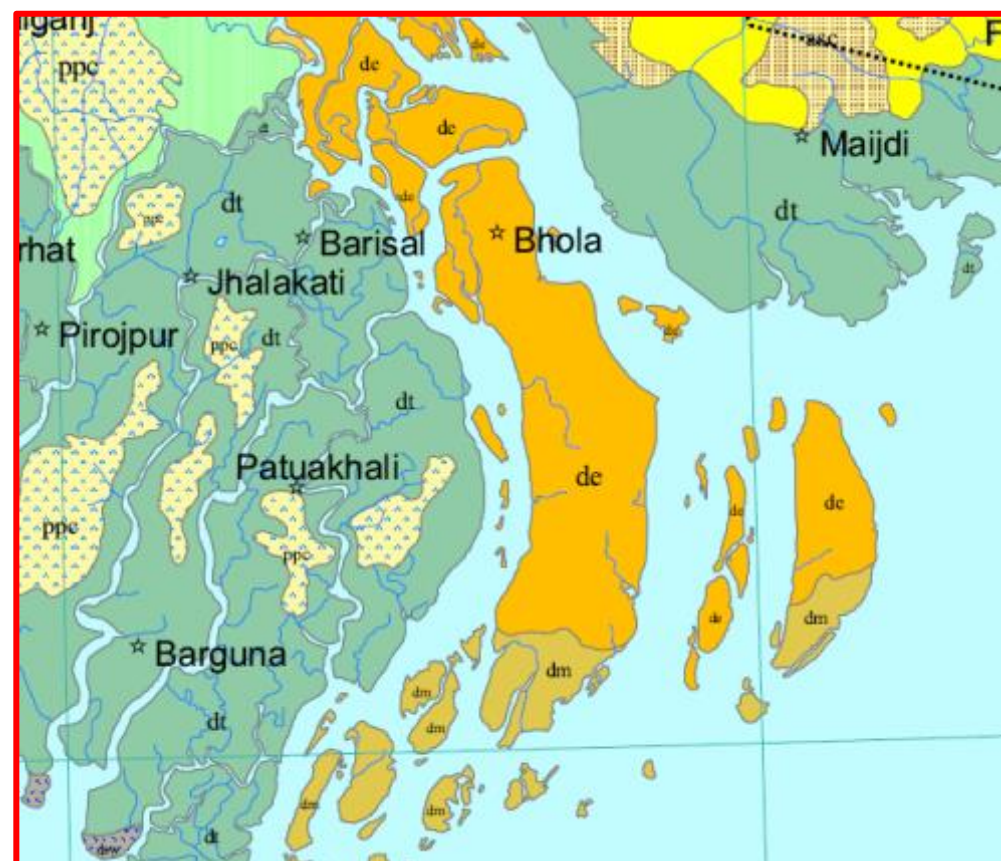
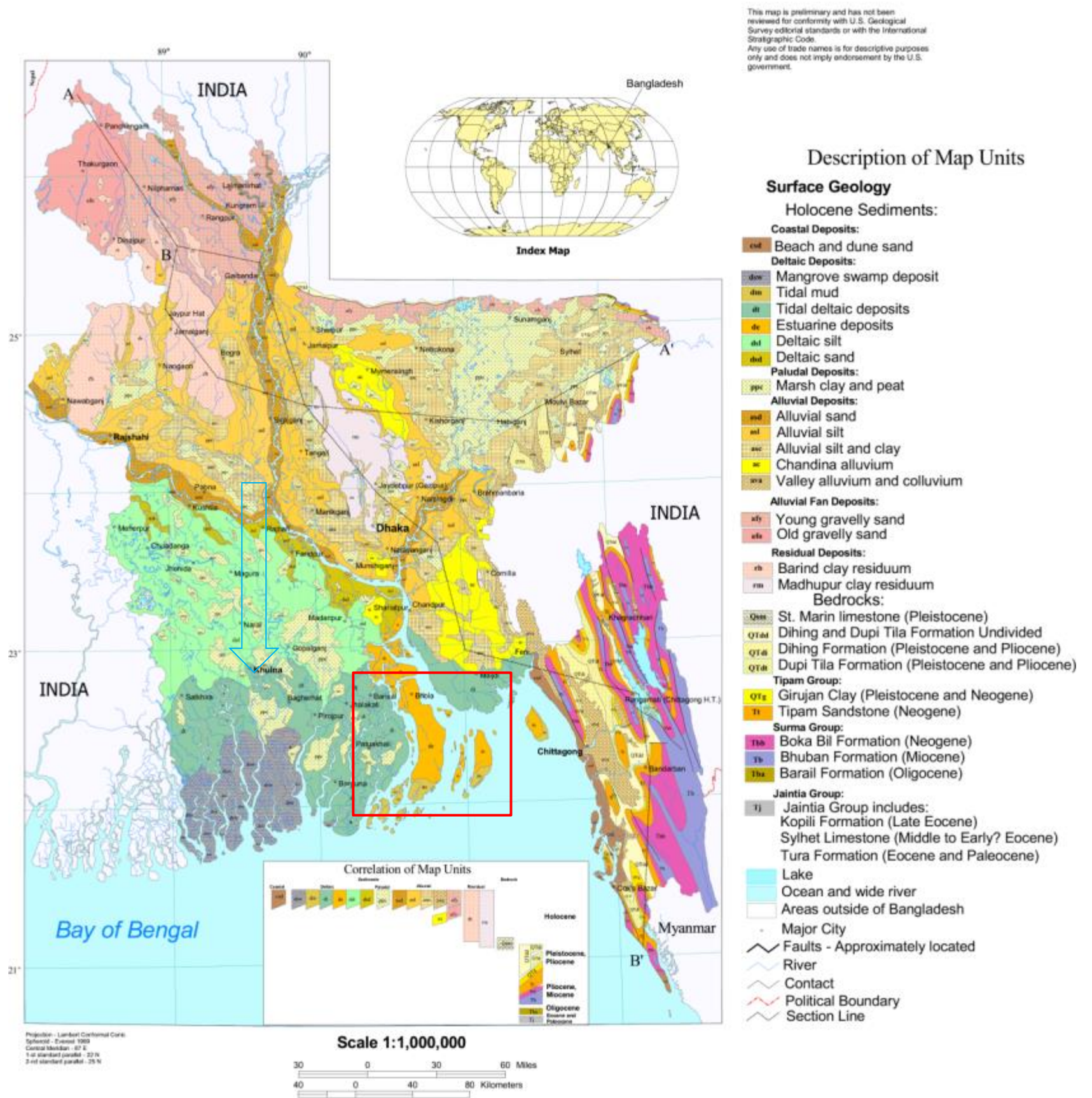
Figure 4.7 Bhola Island: Part of an Active Delta



Source: Banglapedia



Figure 4.8 Geological Map of Bangladesh



Source: Geological Survey of Bangladesh (www.gsb.gov.bd)

#### 4.3.4

### Soil and Sediment Quality

#### Sampling Methodology and Locations

The soil and sediment sampling strategy was designed to assess the existing soil quality over the study area. Samples were collected from a total four (4) locations within the study area. The detail of the sampling locations is presented in *Table 4.3* and *Figure 4.9*. A composite sampling technique<sup>1</sup> was used for soil and sediment sampling from each location.

**Table 4.3** *Location of Soil and Sediment Samples*

S. No.	Sample type	Sample Code	Sampling Location	Geographical Location	Landuse and justification
1	Soil	SQ1	Top soil from the Site	22°28'40.03"N 90°42'32.79"E	Project site filled with river sand
2	Soil	SQ2	Agricultural land (to be acquired for the Project)	22°28'49.34"N 90°42'33.04"E	Agricultural field
3	Sediment	SE1	Dehular Canal (500 m towards plant site from kheyra ghat bridge)	22°29'6.12"N 90°42'30.33"E	Waterbody-Dehular Canal representing sediment near water outfall
4	Sediment	SE2	Dehular Canal (400 m upstream from water intake point of Bhola-I CCPP)	22°28'26.11"N 90°42'40.50"E	Water body - Dehular Canal adjacent to Project site representing sediment near water intake

Soil samples were collected using tools from a depth of 45 cm from the top soil surface. At each location, soil samples were collected from three spots and homogenized. The homogenized samples were collected following quartering technique and then packed in polythene plastic jars and sealed. The sealed samples were sent to the laboratory for analysis.

Sediment samples were collected using a sediment sampler from the Dehular Khal. The sampling was done from the middle of the width of the stream. At each sampling location, the grab sampling device was set with the jaws cocked open and then the lower the sampler until it rests on the sediment. Post sediment sample collection, the sampler was retrieved slowly to minimize the effect of turbulence, that might result in loss/ disturbance of surface sediments. Polythene plastic bags were used to collect the sample from sampler. At each station three samples were collected and homogenized. Care was taken to minimize the surface disturbance to the sediments. The homogenised samples were then packed in polythene plastic bags, sealed and sent to the laboratory for analysis.

(1) <sup>1</sup> In this technique at any location 2-3 soil samples are collected from different point and then mixed homogeneously to prepare a sample for analysis. Similarly for sediment, 2-3 sediment samples are collected from different points and mixed homogeneously to prepare a sample for analysis.

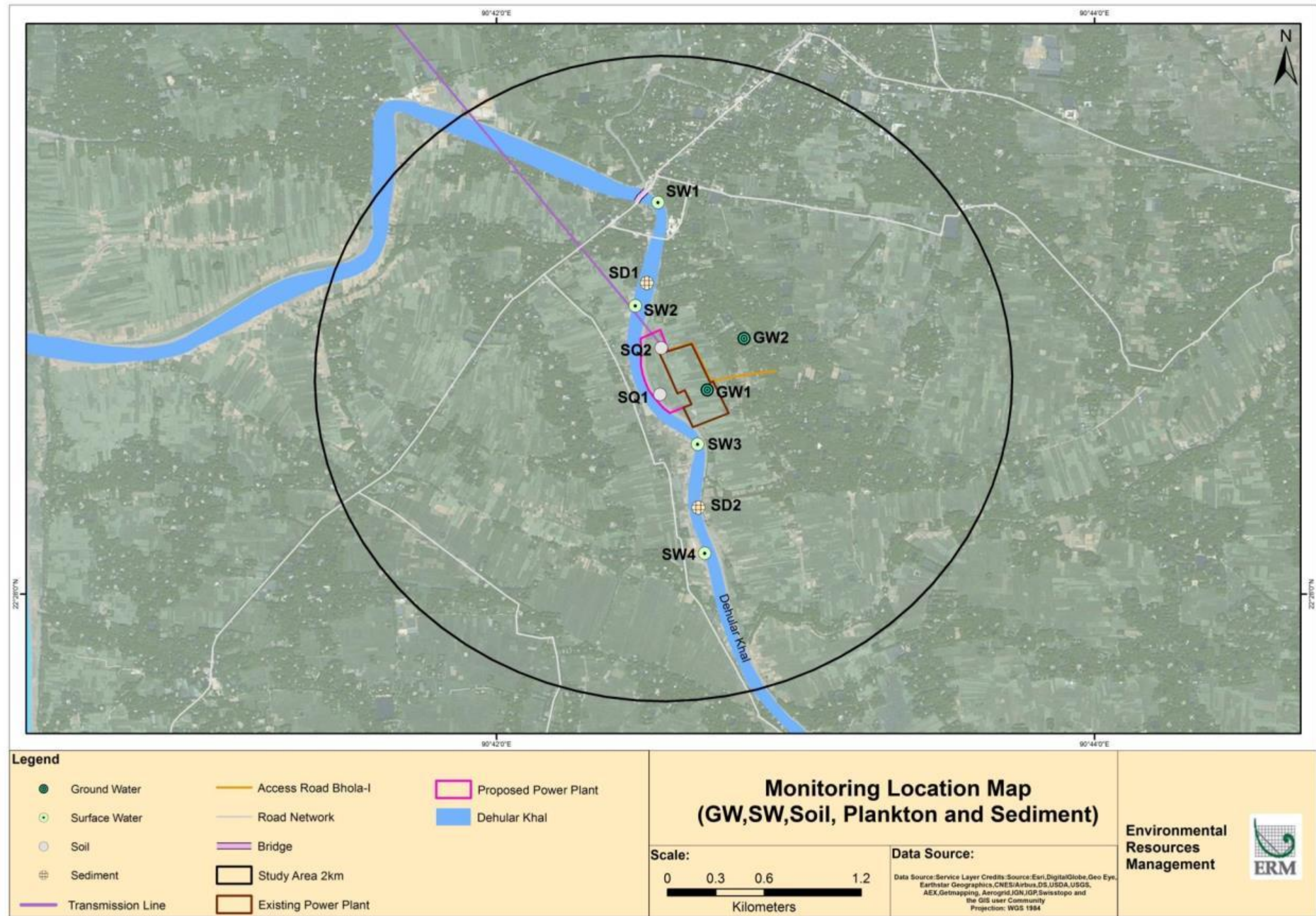
The soil and sediment samples were analysed for physical and chemical characteristics including minerals, heavy metals and trace elements.

*Analysis Results and Discussions*

The analysis results of physico-chemical parameters of soil and sediment samples are presented in **Table 4.4**.



Figure 4.9 Soil, Sediment and Water Sampling Locations



**Table 4.4 Soil and Sediment Quality**

S. No.	Parameters	SQ1	SQ2	SE1	SE2
1.	Particle size distribution	Sand-68% Silt-28% Clay-4%	Sand-32% Silt-51% Clay-17%	Sand-30% Silt-54% Clay-16%	Sand-27% Silt-50% Clay-23%
2.	Texture	Sandy loam	Silty loam	Silty loam	Silty loam
3.	EC (dS/m)	0.72	0.56	0.50	0.48
4.	Bulk Density (g/cm <sup>3</sup> )	1.32	1.53	1.40	1.39
5.	Cation Exchange Capacity (meq of Na/100g soil)	4.71	13.33	18.42	21.53
6.	pH	5.62	6.1	6.5	6.8
7.	Permeability (cm/hr)	10-3 - 10-4 unsaturated soil in dry season	10-1 - 10-4 unsaturated soil in dry season	10-2 - 10-4 unsaturated soil in dry season	10-2 - 10-4 unsaturated soil in dry season
8.	Organic Content (%)	0.38	1.54	0.30	0.28
9.	Calcium (mg/kg)	4.8	7.3	6.8	6.3
10.	Magnesium (mg/kg)	3.4	5.8	6.5	6.3
11.	Potassium (mg/kg)	0.08	0.43	1.7	1.5
12.	Sodium (meq/100g)	0.7	1.84	1.60	1.68
13.	Chloride (mg/g)	82.6	124.2	187.7	196.5
14.	Copper (mg/kg)	5.1	6.8	13.6	12.8
15.	Iron (mg/kg)	57	87	52.7	58.3
16.	Manganese (mg/kg)	36.7	25.3	117.4	134.5
17.	Zinc (mg/kg)	7.82	4.23	23.5	26.7
18.	Lead (mg/kg)	25.5	15.7	27.3	23.6
19.	Cadmium (mg/kg)	1.56	<1.0	0.1	0.1
20.	Arsenic (mg/kg)	1.53	0.45	0.65	0.72
21.	Mercury (mg/kg)	0.4	0.1	0.2	0.2

Source: Lab Analysis Report (2016)

#### *Physical Characteristics of Soil and Sediments*

The particle size distribution of the soil and sediment samples shows major percentage of silt in all the samples, except proposed project site. The soil at the Project site has 68% sand and is of sandy loam texture. This can be attributed to the infilling with river sand depositions in the entire Project site to raise it above flood level initially during site preparation. In the soil sample from agricultural land (SQ2) located near the existing boundary of BPDB land shows more percentage of clay as compared to sand. The sediment samples are clay loam and silty clay loam in texture.

#### *pH of Soil and Sediments*

The pH of the soil sample from the site and nearby agricultural land was moderately acidic in nature as per the standard soil classification given in **Table 4.5**. The pH level of sediments collected from the Dehular Canal was slightly acidic in nature.

**Table 4.5**      *Standard Soil Classification*

<b>pH</b>	<b>Classification</b>
<4.5	Extremely acidic
4.51-5	Very strong acidic
5.01-5.5	Strongly acidic
5.51-6	Moderately acidic
6.1-6.5	Slightly acidic
6.51-7.3	Neutral
7.31-7.8	Slightly alkaline
7.81-8.5	Moderately alkaline
8.51-9.00	Strongly alkaline
>9	Very strongly alkaline

Source: <http://www.esf.edu/pubprog/brochure/soilph/soilph.htm>

#### *Organic Content in Soil*

The organic content of soil greatly influences the plant, animal and microorganism populations in soil. The soil of the Project site was found to have low organic content of 0.38% and that of agricultural land near plant of 1.54 % respectively.

#### *Metals in Soil and Sediment*

Copper, Iron, Manganese, Zinc, Lead, Cadmium, Arsenic and Mercury were detected in the soil and sediment samples. Among these metals, the content of iron, manganese and zinc were highest. It was also observed that Arsenic and Mercury concentrations of filled sand at site were higher than concentrations of these metals in samples taken from agricultural land as well as in both the sediment samples. The exact source of the sand filled at site was not known, however, it was reported that sand was taken from from the Tetulia river. Considering that sand in Tetulia River is deposited from the sediments from the upper reaches, the concentration is much higher than the site level concentrations, which is not directly exposed to the sediment transportation of the main river (because the site is about 6 km away from the Tetulia River).

#### *Criteria for Assessment of Soil and Sediments*

There is no Bangladesh soil or sediment regulation/standard. In the absence of local country standards, it is ERM's practice to use globally recognized 'Dutch Ministry of Public Housing, Land-use and Environmental Guidelines - Soil and Groundwater Standards' to assess soil and sediment quality and to determine the need, if any, for remedial action (*Refer Section 2.9*).

#### *Conclusions*

Metals analysed in baseline quality of both soil and sediment were observed to be well below the threshold limits for Intervention as per the Dutch Standards.



Bhola Island falls under the Ganges tidal flood plain and young Meghna estuarine floodplain and has a network of large number of tidal rivers and their distributaries. The lower Meghna River is highly influenced by the tidal interactions and consequential backwater effects. North and West of Bhola falls under the micro tidal region (0-2m) under the global tidal classification (Hydro-morphological dynamics of the Meghna Estuary by DHV et al, June 2001). Riverine processes dominate the lower Meghna River, Tentulia River and Shabazpur channel surrounding the Bhola Island. All the rivers are connected with streams and tidal channels and flow down to the Bay of Bengal.

Meghna (Lower Meghna), one of the largest rivers of Bangladesh along with its distributary, Shahbazpur channel separates the Bhola district from the Lakshmipur district in the east. The Shahbazpur channel, 5-8 km wide, flows between Bhola and Ramgati-Hatiya islands. The Tentulia river, a channel of Meghna further separates the Bhola island from the rest of the Barisal Division in the west.

As can be observed from the land use of the 10 km study area, about 65 sq km of the study area is covered by rivers and other water bodies. The two main rivers, Tentulia and Shabazpur Canal give the area an island status. Many small ponds, streams and canals exist in the study area. The Kutba Union of the Project area has about 800 ponds. Drainage map of the study radius is shown in *Figure 4.10*.

A perennial channel branching out from the Tentulia River, “Dehular Canal” is flowing adjacent to the Project site on the west. This canal will be used as the source of water for the Project as well as a means to transport machinery and other equipment for construction of the proposed power plant. Another small seasonal canal also exists crossing the proposed approach road to the site. This seasonal canal is very small and not navigable.

The feasibility report by BPDB mentions a bathymetric survey carried out for the Dehular Canal to obtain cross section, bank line, discharge and water level data. It is reported that the minimum cross section area with low tide water level on 03.02.2010 was found to be 135 m<sup>2</sup> considering an average flow of 0.6 m to 1.0 m per second. The average discharge was calculated as 108 m<sup>3</sup> per second.

The yearly maximum and minimum water level for the project site reported in the feasibility report is represented below in *Table 4.6*.

**Table 4.6** *Yearly minimum and maximum water surface level for the project site*

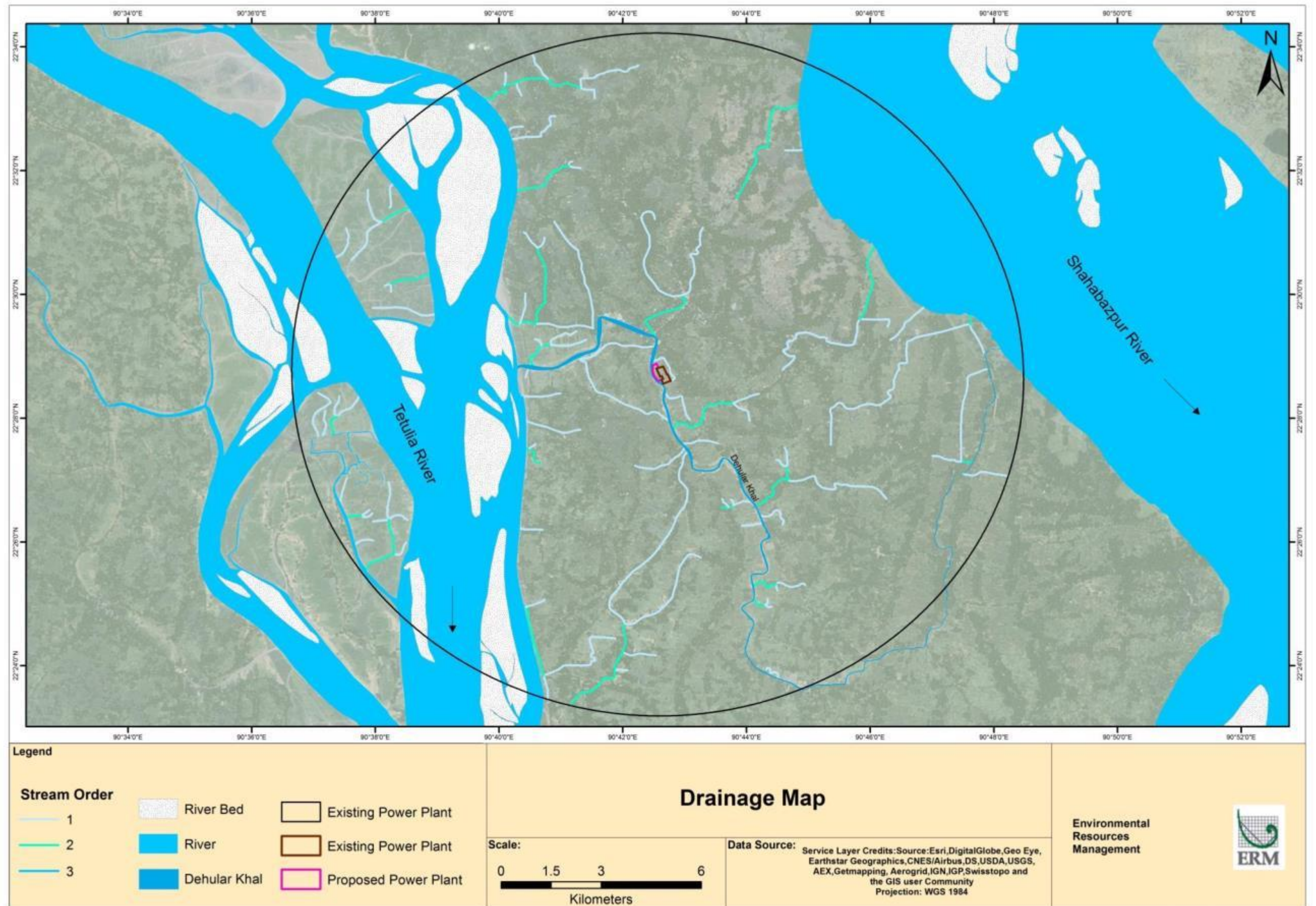
Year	Minimum Water Surface Level (m) (recorded in month of January)	Maximum Water Surface Level (m) (recorded in the month of August)
1988	- 0.82	2.95
1989	-0.82	2.74

Year	Minimum Water Surface Level (m) (recorded in month of January)	Maximum Water Surface Level (m) (recorded in the month of August)
1990	-0.80	3.18
1991	-0.47	3.10
1992	-0.90	2.80
1993	-1.00	3.15
1994	-1.03	3.23
1995	-1.37	2.87
1996	-1.27	3.44
1997	-1.27	3.31
1998	-1.45	3.21
1999	-0.97	3.08
2000	-1.18	3.18
2001	-1.22	3.03
2002	-	2.62
2003	-1.00	2.39
2004		-
2005		1.32
2006		-
2007	-1.68	-
2008	-1.58	-

*Source: BPDB's Feasibility Report of Bhola Power Plant: June 2010*

The 100 years and 50 years flood level of the Dehular canal have been found as 3.44 m and 2.94 m respectively. The depth of water in submerged areas on the Project site against 100 years and 50 years flood is about 1.5 m and 1.0 m, respectively.

Figure 4.10 Drainage Map of Project AOI



#### 4.3.6

#### Water Quality

Water sampling and analysis was undertaken to understand the overall baseline water quality characteristics of the surface and groundwater in the Project AOI. The surface water sampling was based on the identification of the major surface water body and its interaction with the project e.g. Dehular Canal. Groundwater sampling locations were selected to obtain representative water samples from various zones within the AOI. The samples were collected from existing tube well (hand-pumps being used by the villagers) and bore well.

A total of 6 samples, four (4) surface water and two (2) ground water samples were collected. Detail of the sampling location is provided in *Table 4.7* and depicted in *Figure 4.9*.

**Table 4.7** *Details of Surface and Ground Water Sampling Locations*

S. No.	Sampling Location	Code	Geographical Location	Type of Source
1	100m towards the power plant site from kheya ghat bridge	SW1	22°29'18.50"N 90°42'32.40"E	Canal
2	300m upstream from the power plant location	SW2	22°28'57.78"N 90°42'27.86"E	Canal
3	300 m downstream from power plant location	SW3	22°28'30.03"N 90°42'40.34"E	Canal
4	1 km downstream from power plant location	SW4	22°28'8.20"N 90°42'41.80"E	Canal
5	Bhola-I CCPP deep tube well	GW1	22°28'40.92"N 90°42'42.30"E	Tubewell
6	Kutuba village	GW2	22°28'51.25"N 90°42'49.68"E	Tubewell

The samples were analysed for parameters covering physical, chemical and bacteriological characteristics as mentioned in the scope of work which includes certain heavy metals, trace elements and toxic constituents.

Water samples were collected as grab water sample in a pre-washed 5-litre plastic jerry can and 250 ml sterilized clean PET bottle for complete physio-chemical and bacteriological tests respectively.

The samples were analysed as per standard procedure/method given in Standard Method for Examination of Water and Wastewater Edition 20, published by APHA. Details of the analysis method and protocol are presented in *Table 4.8*.

**Table 4.8** *Method for Water Analysis*

S.N	Parameter	Method
1.	Temperature	Digital Thermometer
2.	Turbidity	Turbidity meter
3.	pH	pH meter
4.	Salinity	Digital Salinity Meter

S.N	Parameter	Method
5.	Dissolved Oxygen	Digital DO Meter
6.	Conductivity at 25 ° C	Conductivity meter
7.	Total Dissolved Solids	Digital TDS meter
8.	Alkalinity	Titrimetric
9.	Total Hardness	Titrimetric
10.	Chloride	Titrimetric
11.	Arsenic	Atomic Absorption Spectrophotometer (AAS)
12.	Cadmium	AAS
13.	Chromium	AAS
14.	Calcium	Spectrophotometer
15.	Fluoride	UV Visible Spectrophotometer (UVS)
16.	Iron	AAS
17.	Lead	AAS
18.	Mercury	AAS
19.	Potassium	AAS
20.	Sodium	AAS
21.	Boron	AAS
22.	Fecal Coliform	Membrane Filtration Procedure (MFP)
23.	Total Coliform	MFP
24.	BOD	5 days incubation
25.	COD	CRM
26.	Nitrate	Spectrophotometer
27.	Nitrite	Spectrophotometer
28.	Manganese	AAS
29.	Phosphate	Spectrophotometer
30.	Oil & Grease	Purge Trap GC

The quality of surface water was compared with the standards for *Inland Surface Water*, Environment Conservation Rules (ECR), 1997-Schedule 3 whereas the groundwater was compared with the *Drinking Water Standard* E.C.R .-Schedule-3, 1997. The standards have been presented along with the monitoring results of surface and groundwater for comparison.

#### *Surface Water Quality*

The surface water Quality was compared with the Bangladesh ECR standard for best practice based classification criteria. **Table 4.9** shows the analysis results.

As per the best practice based classification standards of the Bangladesh ECR, the quality of most of the surface water samples from the Dehular Canal is of a level that can be utilized for fisheries, industrial process and cooling purpose and for irrigation. Some of the water analysis parameters are discussed below in detail:

#### *pH*

All results for pH in surface water fell within the permissible limits of 7.82 to 7.87.

#### *Dissolved Oxygen (DO)*

The DO of all the samples of the Dehular Canal range in between 6.2 to 6.4 mg/l and thus meets the surface water classification for different usages.

BOD

The BOD levels range between 4.5 to 5.0 mg/l for the Dehular Canal and thus is well below the permissible limits.



Table 4.9 Surface Water Quality Analysis

S.N	Parameter	Unit	Sample Location				Bangladesh standards (Best practice based classification)*					
			SW1	SW2	SW3	SW4	Source of drinking water for supply only after disinfecting	Water usable for recreational activity	Source of drinking water for supply after conventional treatment	Water usable by fisheries	Water usable by various process and cooling industries	Water usable for irrigation
1.	Temperature	°C	33.2	32.2	31.7	32.8	-	-	-	-	-	-
2.	TDS	mg/L	340	340	350	330	-	-	-	-	-	-
3.	EC	μS/cm	670	700	670	660	-	-	-	-	-	2250 (at temp of 25 °C)
4.	DO	mg/L	6.4	6.2	6.0	6.2	6 or above	5 or above	6 or above	5 or above	5 or above	5 or above
5.	pH	-	7.83	7.87	7.87	7.82	6.5-8.5	6.5 – 8.5	6.5 – 8.5	6.5 – 8.5	6.5 – 8.5	6.5 – 8.5
6.	Salinity	mg/L	300	300	300	300	-	-	-	-	-	-
7.	BOD <sub>5</sub>	mg/L	4.5	4.8	4.7	5.0	2 or less	3 or less	6 or less	6 or less	10 or less	10 or less
8.	COD	mg/L	9.5	11.6	10.4	12.5	-	-	-	-	-	-
9.	Nitrate	mg/L	0.85	0.90	0.80	0.98	-	-	-	-	-	-
10.	Nitrite	mg/L	<0.05	<0.05	<0.05	<0.05	-	-	-	-	-	-
11.	Manganese	mg/L	BDL	BDL	BDL	BDL	-	-	-	-	-	-
12.	Phosphate	mg/L	0.72	0.69	0.65	0.78	-	-	-	-	-	-
13.	Iron	mg/L	0.62	0.65	0.58	0.69	-	-	-	-	-	-
14.	Turbidity	NTU	26	28	23	30	-	-	-	-	-	-
15.	Oil and Grease	mg/L	BDL	BDL	BDL	BDL	-	-	-	-	-	-
16.	Total Coliform	n/100ml	26	35	28	39	-	-	-	-	-	-
17.	Fecal Coliform	n/100ml	Present	Present	Present	Present	-	-	-	-	-	-
18.	Alkalinity (HCO <sub>3</sub> )	mg/l	132	126	128	137	-	-	-	-	-	-
19.	Total Hardness (as CaCO <sub>3</sub> )	mg/l	32.5	34.7	28.7	37.3	-	-	-	-	-	-



S.N	Parameter	Unit	Sample Location				Bangladesh standards (Best practice based classification)*					
			SW1	SW2	SW3	SW4	Source of drinking water for supply only after disinfecting	Water usable for recreational activity	Source of drinking water for supply after conventional treatment	Water usable by fisheries	Water usable by various process and cooling industries	Water usable for irrigation
20.	Chloride (Cl)	mg/l	16.3	22.6	18.4	27.6	-	-	-	-	-	-
21.	Arsenic (As)	mg/l	<0.005	<0.005	<0.005	<0.005	-	-	-	-	-	-
22.	Calcium (Ca)	mg/l	10.4	14.4	18.3	16.8	-	-	-	-	-	-
23.	Chromium (Cr)	mg/l	<0.01	<0.01	<0.01	<0.01	-	-	-	-	-	-
24.	Fluride (F)	mg/l	<0.10	<0.10	<0.10	<0.10	-	-	-	-	-	-
25.	Cadmium (Cd)	mg/l	<0.005	<0.005	<0.005	<0.005	-	-	-	-	-	-
26.	Lead (Pb)	mg/l	<0.005	<0.005	<0.005	<0.005	-	-	-	-	-	-
27.	Mercury (Hg)	mg/l	<0.001	<0.001	<0.001	<0.001	-	-	-	-	-	-
28.	Potassium (K)	mg/l	5.42	4.76	5.10	4.95	-	-	-	-	-	-
29.	Sodium (Na)	mg/l	18.51	21.45	19.42	23.67	-	-	-	-	-	-
30.	Boron (B)	mg/l	<0.05	<0.05	<0.05	<0.05	-	-	-	-	-	-

\* Bangladesh Environment Conservation Rules, 1997- Schedule 3 (Standards for inland surface water)

## Groundwater Quality

The results of two groundwater samples collected from the borewells in Bhola-I CCPP deep tubewell and from Kutba village borewell are shown in **Table 4.10**.

**Table 4.10** Groundwater quality analysis

Parameters	Units	GW1	GW2	Bangladesh Standards*
Temperature	°C	29.1	28.8	20-30°C
TDS	mg/l	390	420	1000
EC	µS/cm	570	620	-
pH		7.32	7.24	6.5-8.5
Salinity	mg/l	200	200	-
Alkalinity (HCO <sub>3</sub> )	mg/l	243	267	-
Total Hardness (as CaCO <sub>3</sub> )	mg/l	17.2	15.4	200 - 500
Chloride (Cl <sup>-</sup> )	mg/l	67.8	54.2	150-600
Arsenic (As)	mg/l	<0.05	<0.05	0.05
Calcium (Ca)	mg/l	42.1	35.6	75.0
Chromium (Cr)	mg/l	<0.01	<0.01	0.05
Cadmium (Cd)	mg/l	<0.005	<0.005	0.005
Iron (Fe)	mg/l	0.37	1.31	0.3-1.0
Lead (Pb)	mg/l	<0.01	<0.01	0.05
Mercury (Hg)	mg/l	<0.001	<0.001	0.001
Potassium (K)	mg/l	1.28	1.37	12.0
Sodium (Na)	mg/l	47.5	58.7	200
Boron (B)	mg/l	0.16	0.27	1.0
Fecal Coliform	mg/l	0	0	0
Total Coliform	mg/l	0	0	0
Fluride (F)	mg/l	0.37	0.41	-

\* Bangladesh Environment Conservation Rules, 1997- Schedule 3 (Standards for drinking water)

The key parameters in groundwater are discussed below, compared with the Bangladesh ECR Standards for drinking water.

### pH

The pH of the samples varies in the range of 7.32 to 7.24 which is well within the standard range of 6.5 to 8.5.

### Total Hardness

Total Hardness varied in the range of 15.4 to 17.2 mg/l and is well within the standard limit of 200-500 mg/l.

### Chloride

The chloride content in the samples varied in the range of 54.2 to 67.8 and is well within the permissible standards of 150-600 mg/l.

#### Iron and Arsenic

The iron content of the groundwater samples varied in the range of 0.37 to 1.31 mg/l. The iron content at two borewells exceeds standard range of 0.3 to 1 mg/l indicating high iron content in the ground waters of the study area.

Arsenic content at two sampling locations was <0.05 mg/l and is within the permissible limit.

#### Conclusion

The ground water quality in the study area is fit for drinking purpose. No contamination was recorded.

### 4.3.7

#### *Meteorology*

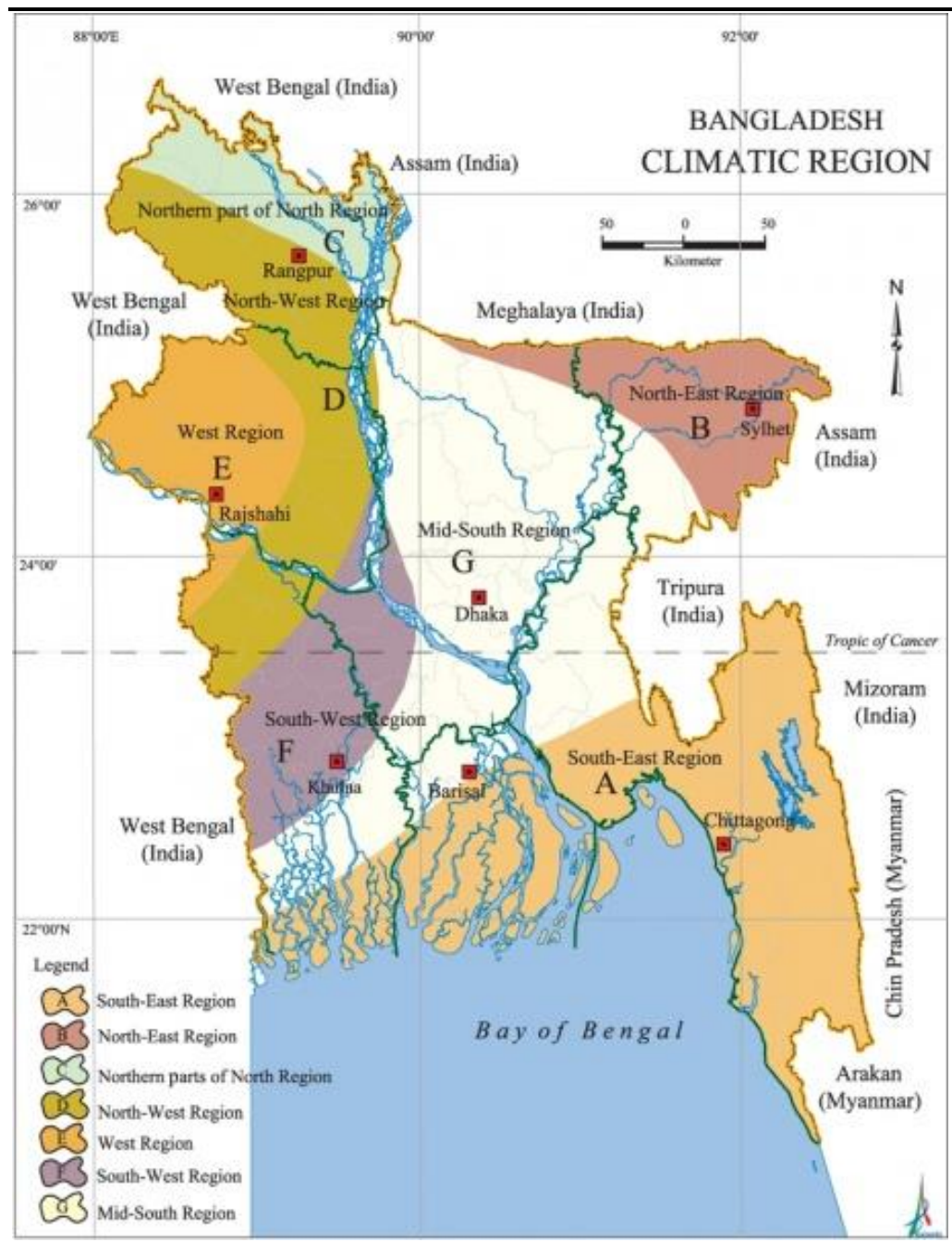
##### *Climate*

Bangladesh is located in the tropical monsoon region and its climate is characterised by high temperature, heavy rainfall, often excessive humidity, and fairly marked seasonal variations. From the climatic point of view, three distinct seasons can be recognised in Bangladesh - the cool dry season from November through February, the pre-monsoon hot season from March through May, and the rainy monsoon season which lasts from June through September. January is the coolest month with temperatures averaging near 26°C and April the warmest with temperatures from 33 to 36°C. Most places receive more than 1,525 mm of rain a year, and areas near the hills receive 5,080 mm. Most rains occur during the monsoon (June-September) and little in winter (November-February). Moderate rains also reported in the months of March, April and October.

Climatic sub-regions of Bangladesh are presented in *Figure 4.11* and as per that, the Bhola District falls in the South-Eastern Zone. The nearest Bangladesh Meteorological Department (BMD)<sup>1</sup> meteorological station is at Bhola Town, which is about 25 km north of the Project site. The climatic conditions as recorded at Bhola therefore can be considered applicable for the Project. To assess the climatic conditions of the area, climatology data has been obtained from Bangladesh Meteorological Department (BMD) for the period 1966 - 2011.

(1) <sup>1</sup> Bangladesh Meteorological Department is the authorised Government organisation for all meteorological activities in Bangladesh. It maintains a network of surface and upper air observatories, radar and satellite stations, agro-meteorological observatories, geomagnetic and seismological observatories and meteorological telecommunication system.

Figure 4.11 Climatic Sub-regions of Bangladesh

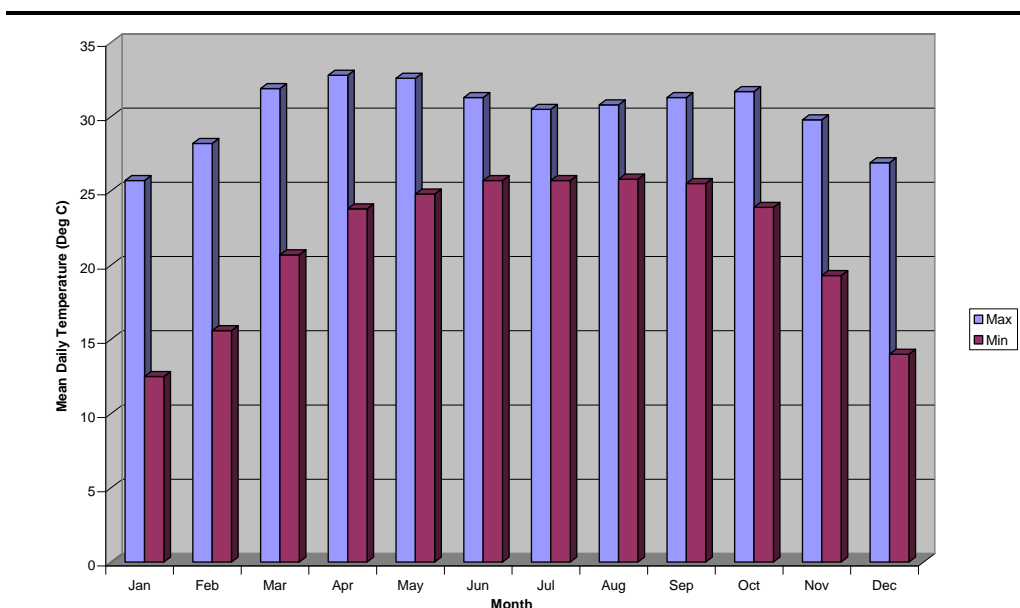


### Temperature

Temperature records from observatory at Bhola are available for last 45 years. The period from March to May is marked by continuous increase in the temperatures. April is the hottest months of the year with a mean daily maximum and minimum temperature (in April) of 32.8°C and 23.8°C, respectively. The extreme maximum and minimum temperatures recorded in last 45 years are 37.9°C (1966) and 13.4°C (1998), respectively. With the onset of monsoon by mid-May, the temperatures descend slightly. The mean daily maximum temperature during the monsoon season (mid-May to September-end) varies from 32.8°C to 30.5°C. From November onwards, both the day and night temperatures decrease and January is the coldest month, with daily maximum and minimum temperatures of 25.7°C and 12.5°C. The monthly

variation of normal maximum and minimum temperatures in Bhola has been presented in *Figure 4.12*:

**Figure 4.12** *Normal Maximum and Minimum Temperature Profile in Bhola*

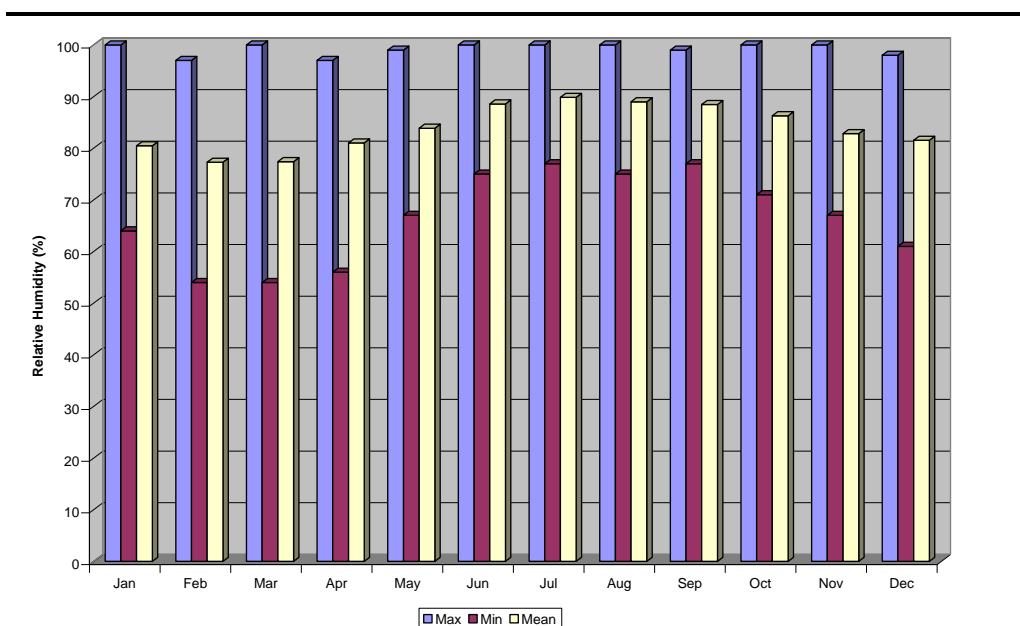


Source: BMD

### Humidity

Due to heavy rainfall and proximity to Bay of Bengal, the humidity levels in the area remains high. Relative humidity in Bhola is generally above 80% throughout the year except in the months of February and March. Minimum average daily relative humidity is 61% during the month of December. The annual average humidity is about 83.9%. The monthly variation of daily average maximum, minimum and mean relative humidity in Bhola has been presented in *Figure 4.13*.

**Figure 4.13** *Normals of Relative Humidity in Bhola*

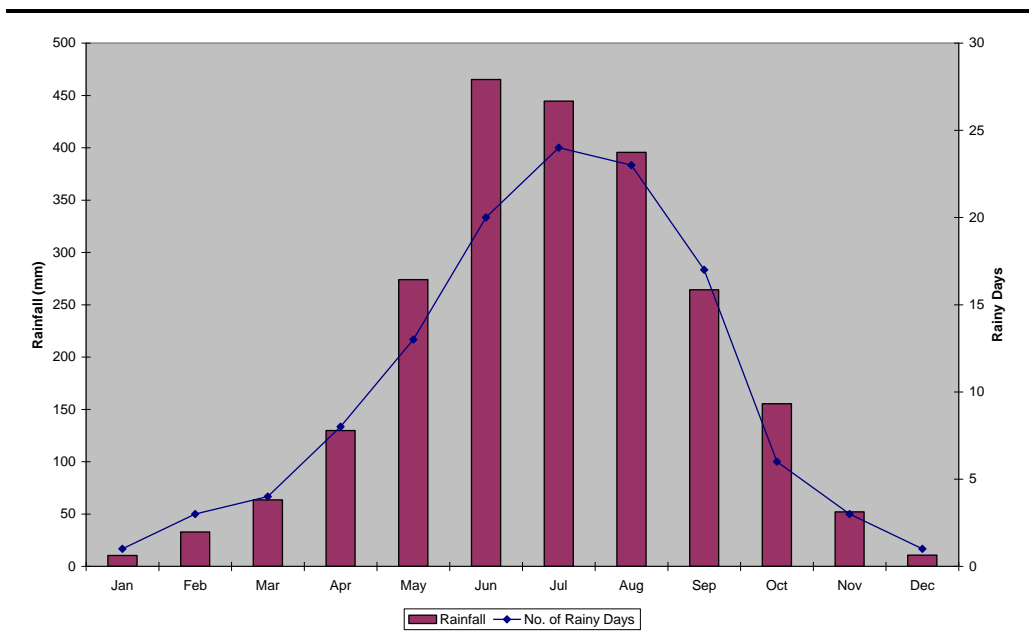


Rainfall

Average annual rainfall based on rainfall data recorded at Bhola for last 45 years is 2297.4 mm. Of the annual rainfall, about 80% fall during five monsoon months (May to September) with June and July getting the maximum rains. Minimum precipitations are reported during the months of November to February, whereas average showering does occur in March, April and October. Annual rainfall varies from 1609 mm (1992) to 3148 mm (1983).

The monthly rainfall variation based on the climatology data and number of rainy days in each month in Bhola has been presented in *Figure 4.14*:

**Figure 4.14** Normals of Rainfall in Bhola



Wind Speed and Wind Direction

Wind direction and speed keeps changing due to seasonal variations. Prevalent wind direction is south/north and vice versa. Winds are generally moderate during non-monsoon season, whereas during the monsoon season, these are moderate to strong. The wind speed varies from 2.0 knots to 15.0 knots, with average wind speed of about 7.0 knots. Meteorological data for the project site was also collected from the MM5 processed data. Monthly windroses based on the meteorological data for year 2015 is presented in *Figure 4.15*. Annual windrose diagram and wind class frequency distribution is presented in *Figure 4.16*.

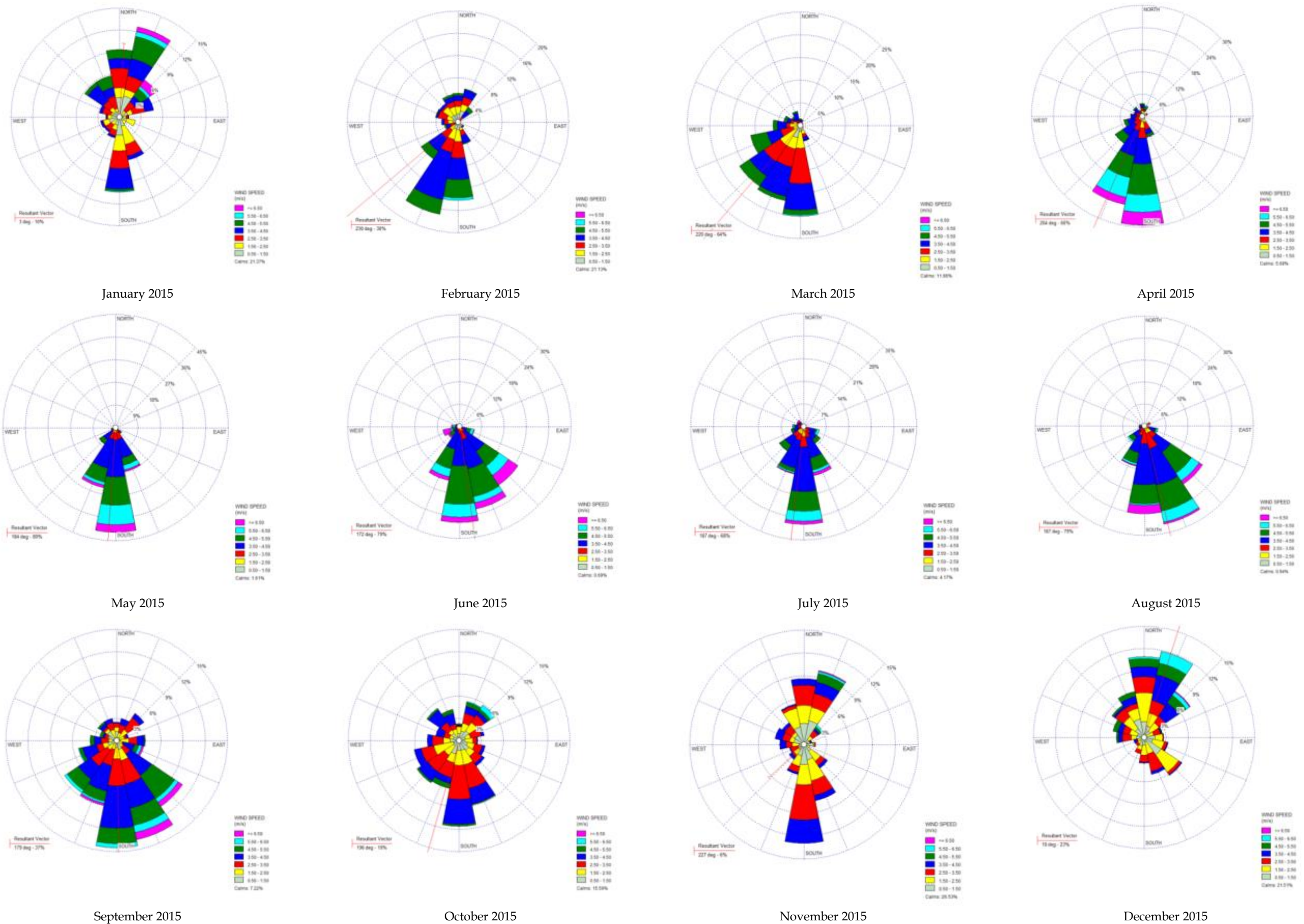
Cloud Cover

The cloud cover has two opposing seasonal patterns, coinciding with winter and monsoon season. As a result of the flow of cold-dry winds from the north-western part of India during the winter season, the cloud cover is at a minimum. On average, the cloud cover in this season is about 10% almost all over the country. With the progression of the season, the cloud cover

increases, reaching 50-60% by the end of the pre-monsoon hot season. During the monsoon season, the cloud cover is very widespread. In the months of July and August, which is the middle of the monsoon season, the cloud cover varies from 75 to 90% all over the country. However, it is more extensive in the southern and eastern parts (90%) than in the north-western part (75%). After the withdrawal of the monsoon, the cloud cover decreases rapidly, dropping to 25% in the northern and western parts, and 40-50% in the southern and eastern parts.

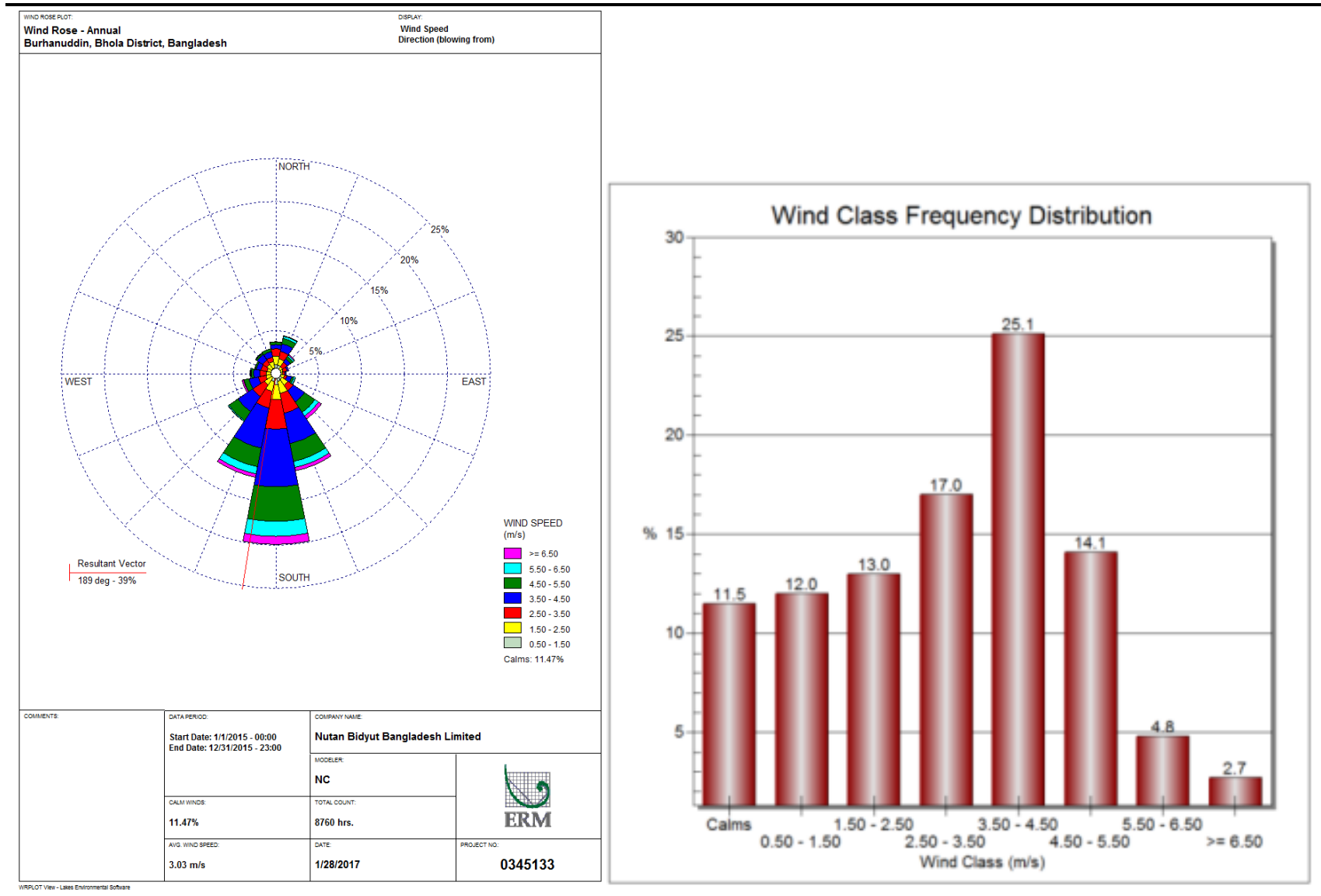


Figure 4.15 Monthly Windrose Diagrams of Project Site



Source: Pre-processed meteorological data from MM5 for Project Site

Figure 4.16 Annual Wind Rose and Wind Class Frequency Distribution



*Earthquakes*

As per the Seismic Zoning Map of Bangladesh, the country is divided into four seismic zones and the design strength of buildings is stipulated in each seismic zone. As per the latest Bangladesh National Building Code, the project site and study area is located in Seismic Zone I resulting in a seismic zone factor of  $Z = 0.12$  (*Figure 4.17*). The northern part of the country that includes the greater districts of Rangpur, Mymensingh, and Sylhet are in the Zone-IV, where earthquake shock of maximum intensity of IX of the Modified Mercalli Scale is possible. The Zone-II includes the greater districts of Dinajpur, Bogra, Dhaka and Chittagong and the shocks of intensity of VIII are possible. The southern part of the country, the least active region, where the maximum intensity is not likely to exceed VII, is in the Zone-III. The Project site along with the entire Bhola Island falls in the Zone-I area.

Seismicity map of Bangladesh and neighbouring countries is presented in *Figure 4.18*, which also indicate that there is no seismic activity in the delta region of Bangladesh.

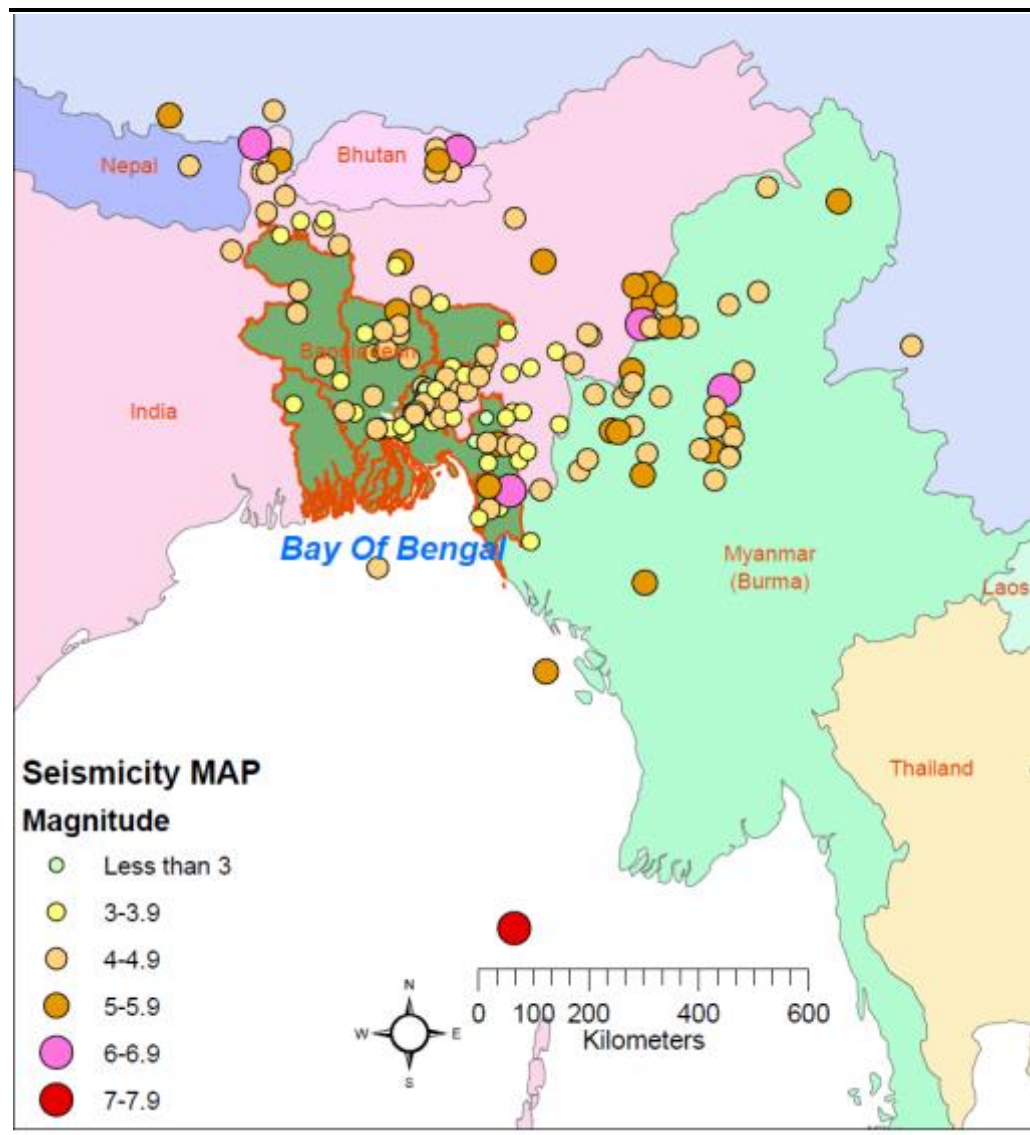
Figure 4.17 Earthquake Zone Map of Bangladesh



Source: Bangladesh National Building Code, Final Draft 2015, prepared by Housing and Building Research Institute



Figure 4.18 Seismicity Map of Bangladesh and Neighbouring Areas



Source: BMD

#### Cyclone and storm surges

Devastating cyclones hit the coastal areas of Bangladesh almost every year usually accompanied by high-speed winds, sometimes reaching 250 km/hr or more and 3-10m high waves, causing extensive damage to life, property and livestock. Because of the funnel shaped coast, Bangladesh repeatedly becomes the landing ground of cyclones formed in the Bay of Bengal. The offshore islands of Bhola are among the islands most prone to the cyclones. These cyclones occur in two seasons, April-May and October-November - i.e. before and after the monsoon.

Cyclones in Bangladesh are presently classified according to their intensity and the following nomenclature is in use:

- depression (winds upto 62 km/hr);
- cyclonic storm (winds from 63 to 87 km/hr);
- severe cyclonic storm (winds from 88 to 118 km/hr); and

- very severe cyclonic storm of hurricane intensity (winds above 118 km/hr).

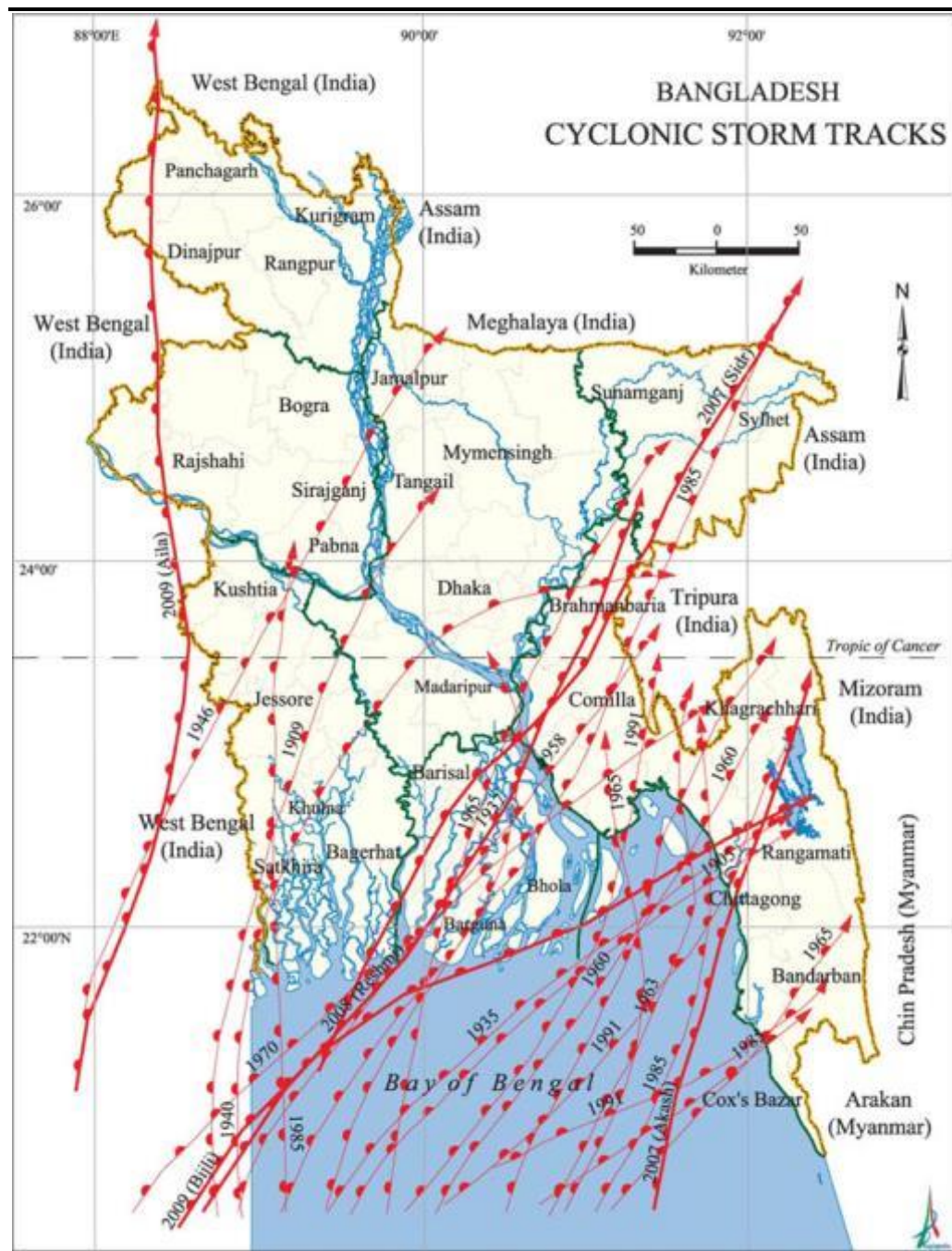
Some of the most devastating natural disasters in recorded history with high casualties were tropical cyclones that hit the region. Among them, the 1970 Bhola cyclone alone claimed more than 500,000 lives. A chronology of major cyclonic storms, which had hit Bhola is presented in *Table 4.11* and key cyclonic storm tracks in Bangladesh has been shown in *Figure 4.19*.

**Table 4.11** *Cyclonic Storms in Bhola*

S. No.	Date/Year	Nomenclature	Relevant Information
1.	12-13 November, 1970	Very severe cyclonic storm (hurricane)	Maximum wind speed - 222 km/hr Maximum storm surge - 10.6 m
2.	9-12 May, 1975	Severe cyclonic storm	Maximum wind speed - 112.6 km/hr
3.	29 April, 1991	Very severe cyclonic storm (hurricane)	Maximum wind speed - 178 km/hr
4.	16-19 May, 1997	Very severe cyclonic storm (hurricane)	Maximum wind speed - 225 km/hr Maximum storm surge - 3.05 m
5.	25-27 September, 1997	Very severe cyclonic storm (hurricane)	Maximum wind speed - 150 km/hr Maximum storm surge - 3.05 m
6.	11-16, November, 2007	Severe cyclonic storm	Maximum wind speed - 126 km/hr
7.	27 May, 2009	Severe cyclonic storm	Maximum wind speed - 120 km/hr

*Source: Banglapedia and India Meteorology Department*

Figure 4.19 Cyclonic Storm Tracks in Bangladesh

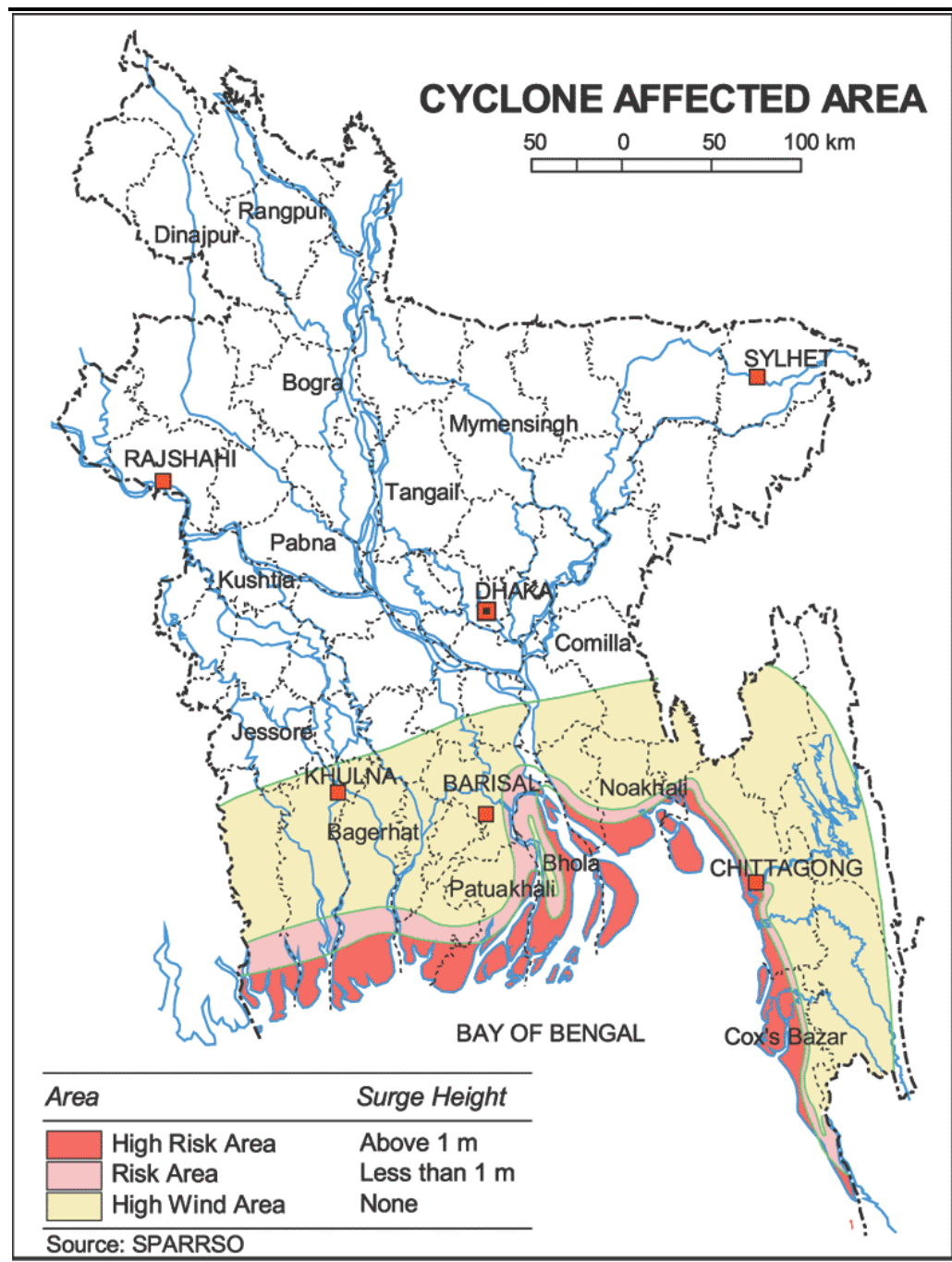


Source: Banglapedia

Figure 4.20 shows cyclone affected areas of Bangladesh. From the figure it is very clear that many areas of Bhola Island are in the high risk zone of cyclone facing storm surges of above 1 m height. However the Project area situated centrally in the Bhola Island falls in the high wind zone and is not affected by storm surges.



Figure 4.20 Cyclone map of Bangladesh



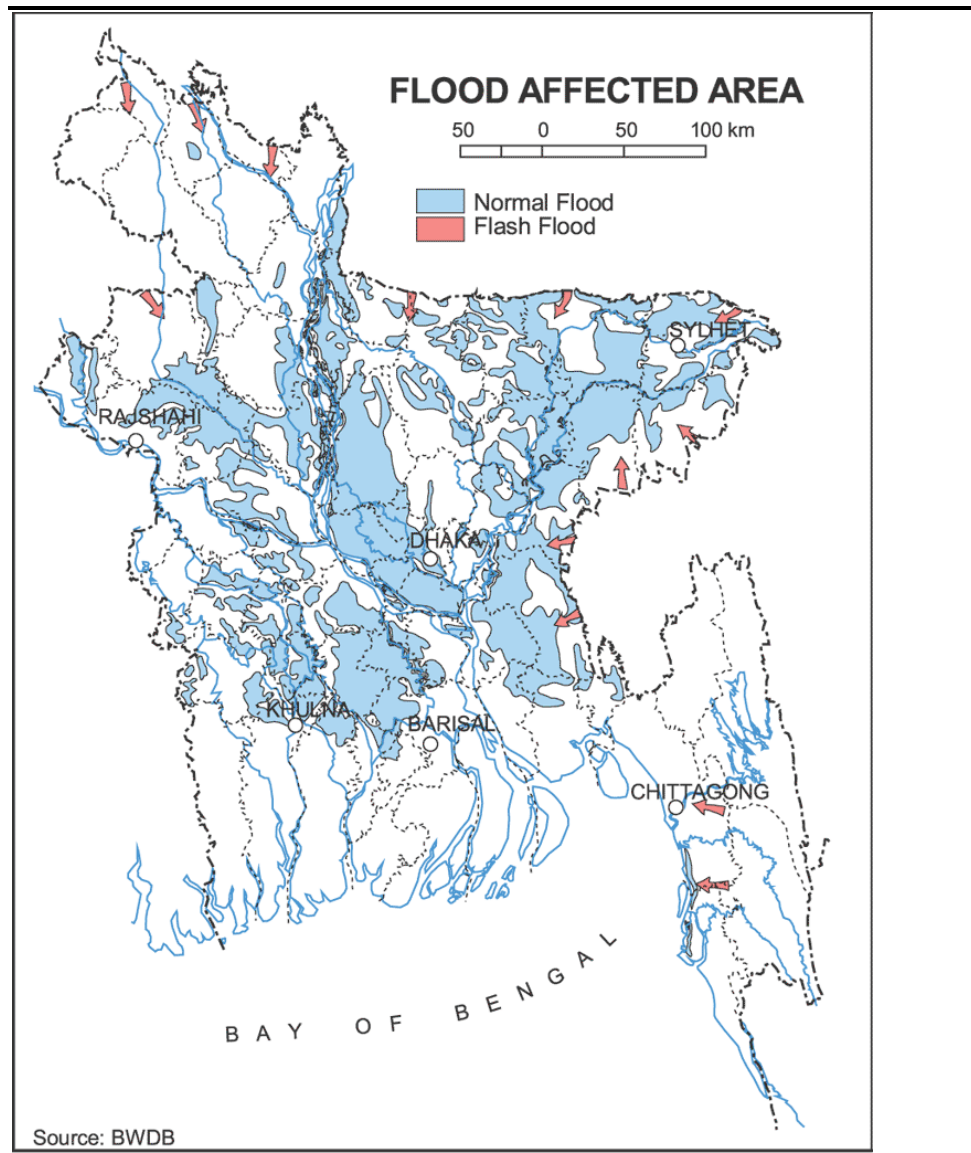
### Floods

Every year near about one-fifth of Bangladesh undergoes flood during the monsoon season. A flood season in Bangladesh may start as early as May and can continue until November.

Floods of Bangladesh can be divided into three categories: (i) monsoon flood - seasonal, increases slowly and decreases slowly, inundate vast areas and causes huge loss to the life and property; (ii) flash flood-from sudden torrential flows, following a brief intense rainstorm or the bursting of a natural or man made dam or levee; and (iii) tidal flood - short duration, height is generally 3-6m, prevents inland flood drainage.

Figure 4.21 shows the flood affected areas of Bangladesh. The Bhola Island near the northern boundaries is prone to flooding. The Project site is also affected by flood waters in the monsoon season because of the Dehular Canal adjacent to the site. It is reported that the site comes under 0.60 - 1.2 m of water for a few days during the peak monsoon season. In order to avoid any flooding event, BPDB has raised the land about +4.10 m above MSL and flood embankment has been constructed. Same elevation is planned for the proposed project site of Bhola-II CCPP.

Figure 4.21 Flood Map of Bangladesh



### Climate Vulnerability

In order to understand the climate vulnerability of the site with respect to submergence and erosion/ accretion over a period of 21 years, satellite imagery data of Year 1995, Year 2001 and Year 2016 has been utilised to assess the change in landuse. Landuse and Landcover map of the study area in different years has been presented in Figure 4.22. Area break-up of different

landuse/landcover components during different years has been presented in Table 4.12.

**Table 4.12 Landuse and Landcover of the Study Area - Year 1995, 2001 and 2016**

Land Use/ Land Cover Category	Area (Sq_km)_1995	Area (Sq_km)_2001	Area (Sq_km)_2016
Agriculture	135.00	127.74	102.64
Brick kiln	-	-	0.14
Dehular Khal	1.34	1.43	1.42
Homestead Plantation & Vegetation	118.32	97.17	107.89
Industry	-	-	0.18
Mangrove	-	15.16	7.47
Mudflat	25.38	26.91	36.41
River	42.85	53.79	66.15
Road Network	0.73	0.74	0.75
Settlement	0.43	0.98	0.98
Water body	0.21	0.34	0.23
<b>Total</b>	<b>324.26</b>	<b>324.26</b>	<b>324.26</b>

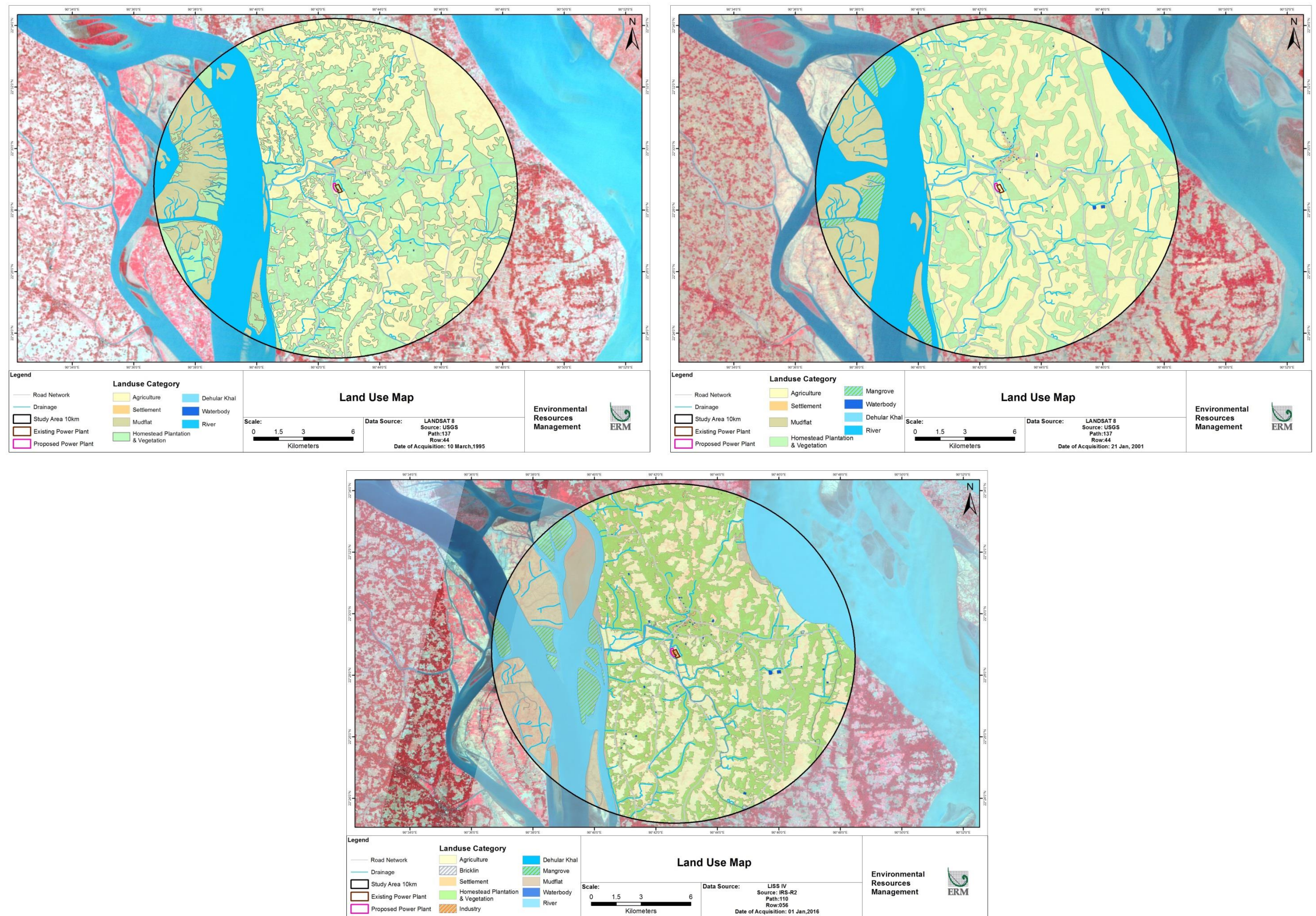
Comparison of landuse and landcover of Year 1995, 2001 and 2016 revealed that:

- Agriculture lands cover majority of the area within the study area. Percentage of agriculture lands had decreased over the year (1995 to 2016) from 41.63% to 31.65%.
- Homestead plantations of settlements viz. Burhanuddin, Bara Manika and Bara Pata was also observed within the study area. Homestead plantation & vegetation also decreased over the year (1995 to 2016) from 36.49% to 33.27%
- Area included under river bed increased during the year 2016 (20.40%) compared to 1995 (13.21%) due to erosion of Tetulia and Shahabazpur rivers at the western and eastern sides of the study area respectively.
- Mudflat significantly increased during the year 1995 to 2016 (7.83% to 11.23%) primarily due to increase in Tetulia river bed.
- Mangrove vegetation was not observed during 1995. Areas with mangrove vegetation were observed during 2001 at Tetulia river banks. During 2016 mangrove vegetation was observed to be decrease due to the emergence of few islands (covered with mangrove vegetation) within the Tetulia River.
- Area covered under settlements also increased gradually from 1995 (0.32%) to 2016 (0.98%).

The comparison of 21 years period clearly indicates that there is erosion and accretion happening on eastern as well as wester part of the island. However, the project site is located almost in the middle of the island and is assessed to be less vulnerable to the implications of erosion and accretion. Other information on induced vulnerability from extreme events and natural hazards has been discussed in the socio-economic baseline profile (refer to *Section 5.8*).



Figure 4.22 Landuse and Landcover - 1995, 2001 and 2016





The objective of the ambient air quality monitoring program was to establish the baseline ambient air quality in the study area. The profile of the study area is mainly rural, which has mix of scattered settlements and agriculture areas with one town (Burhanuddin). The major sources of air pollution noted within the study area include normal vehicular pollution in roads as well as vessels on nearby canal/waterways, agricultural activities, and domestic emissions. No major industrial activity is reported in the study area; however a few brick kilns were sighted in the study area. Energy supplies are not good in the area, and therefore, diesel-fired small power generating sets are common in the semi-urban areas of the study area.

The air quality monitoring locations were selected based on the locations of settlements and receptors within the study area. Logistical factors such as consent of villagers, mainly the house owners, power connection, accessibility, security, etc. were also taken into account in finalising the monitoring stations.

#### *Methodology of Air Quality Monitoring*

The existing ambient air quality of the study area was monitored at five (5) locations during the monitoring period (April-May 2016). The monitoring parameters included Particulate Matter (Suspended Particulate Matter (SPM), PM<sub>10</sub> and PM<sub>2.5</sub>), Sulphur Dioxide (SO<sub>2</sub>), Oxides of Nitrogen (NO<sub>x</sub>) and Carbon Monoxide (CO). All the parameters except CO were monitored on 24-hourly basis twice a week during the duration of the study. CO was monitored as eight-hourly average.

#### *Selection of sampling locations*

The baseline status of the ambient air quality has been established through a scientifically designed ambient air quality monitoring network. The ambient air quality monitoring locations (*Figure 4.23*) were based on the following aspects covered in field survey plan developed prior to the field work:

- Meteorological conditions of the area based on information of BMD observatory at Bhola;
- Topography of the study area; and
- Location of sensitive receptors such as major settlements;

The particulate and gaseous samples collected during the monitoring have been analysed as per the procedures specified in *Table 4.13*. The geographical locations and setting of the ambient air quality monitoring locations has been presented in *Table 4.14* and are depicted in *Figure 4.23*.

**Table 4.13** *Methodology for Analysis of Ambient Air Quality*

S. No.	Parameter	Analysis Procedure
1.	SPM	Gravimetric method
1.	PM10	Gravimetric method

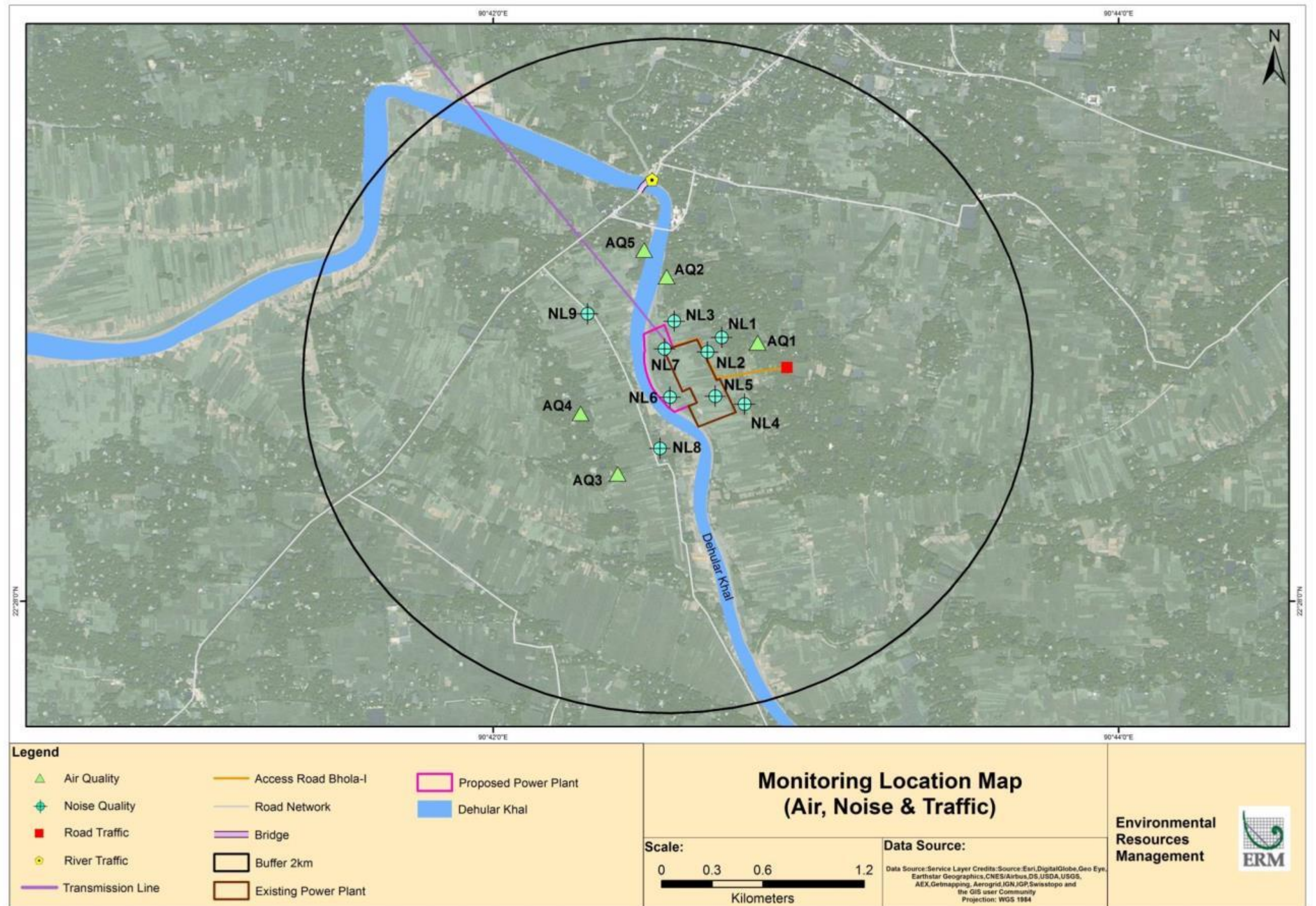
S. No.	Parameter	Analysis Procedure
2.	PM2.5	Gravimetric method
3.	SO <sub>2</sub>	Colorimetric method at 560nm using spectrophotometer (West-Gaeke method)
4.	NO <sub>x</sub>	Colorimetric method at 540 nm using spectrophotometer (Jacob and Hochheiser method)
6.	CO	Indicator tube method

**Table 4.14** *Ambient Air Quality Sampling Locations*

S.N.	Sampling Station	Station Code	Geographical Location	Location Setting
1	Eastern side of the power plant complex (300 m from site and 600 m from plant stacks)	AQ1	22°28'49.52"N 90°42'50.76"E	Village and Rural Setting
2	Northern side of the proposed project (400 m from site and 650 m from plant stacks)	AQ2	22°29'2.20"N 90°42'33.30"E	Village and Rural Setting
3	South-Western side of the proposed project (500 m from site and 570 m from plant stacks)	AQ3	22°28'24.40"N 90°42'23.90"E	Village & Rural Setting
4	Western side of the proposed project (420 m from site and 470 m from plant stacks)	AQ-4	22°28'36.00"N 90°42'16.80"E	Village & Rural Setting
5	Northern side of the proposed project (600 m from site and 820 m from plant stacks)	AQ-5	22°29'7.30"N 90°42'29.00"E	Village & Rural Setting and adjacent to Kheya Ghat

Note: Sampling locations were selected based on preliminary screening of air dispersion, wind rose pattern during the monitoring period and sensitive receptors present in the impact zone. The isopleths of maximum ground level concentrations (refer to *Section 6.4.3*) also confirmed the impact zone within 0.6 - 1.0 km from plant stacks.

Figure 4.23 Air Quality, Noise and Traffic Monitoring Locations Map





## Ambient Air Quality in the Study Area

The monitored ambient air quality is summarized in Table 4.15.

**Table 4.15** *Ambient Air Quality in the Study Area*

Location	Observed	Concentration in ( $\mu\text{g}/\text{m}^3$ )					
		SPM	PM10	PM2.5	SO2	NOx	CO*
AQ1	Maximum	164.17	60.32	38.23	16.34	28.12	180.00
	Minimum	150.41	46.24	31.81	11.45	22.74	160.00
	Average	158.40	54.43	35.49	13.46	24.89	170.00
	98 Percentile	164.03	60.18	38.16	16.19	27.95	179.60
AQ2	Maximum	179.55	52.10	34.83	13.72	24.48	160.00
	Minimum	130.34	43.75	26.58	8.34	19.94	120.00
	Average	150.29	47.35	30.70	10.79	22.63	136.67
	98 Percentile	178.01	51.86	34.66	13.58	24.44	158.80
AQ3	Maximum	196.68	68.45	41.50	16.93	29.03	200.00
	Minimum	165.40	53.25	30.62	14.26	16.71	140.00
	Average	179.57	60.04	36.48	15.17	22.33	166.67
	98 Percentile	195.87	68.05	41.33	16.83	28.72	198.40
AQ4	Maximum	181.92	48.53	31.47	12.58	20.55	170.00
	Minimum	155.85	37.47	21.73	10.28	16.50	140.00
	Average	170.18	44.07	27.25	11.21	18.20	153.33
	98 Percentile	181.56	48.44	31.35	12.51	20.43	169.20
AQ5	Maximum	183.30	66.36	42.35	16.43	25.09	200.00
	Minimum	166.61	56.36	35.82	12.66	21.25	160.00
	Average	174.51	61.71	39.30	14.81	23.25	180.00
	98 Percentile	182.91	66.20	42.24	16.39	25.03	199.20
<b>Standards</b>							
<b>Bangladesh**</b>	<b>24 hourly</b>	<b>200</b>	<b>150</b>	<b>65</b>	<b>365</b>	<b>-</b>	<b>10,000</b>
	<b>Annual</b>	<b>-</b>	<b>50</b>	<b>15</b>	<b>80</b>	<b>100</b>	<b>-</b>
<b>WHO***</b>	<b>24 hourly</b>	<b>-</b>	<b>100</b>	<b>37.5</b>	<b>50</b>	<b>-</b>	<b>10,000</b>
	<b>Annual</b>	<b>-</b>	<b>50</b>	<b>15</b>	<b>-</b>	<b>40</b>	<b>-</b>

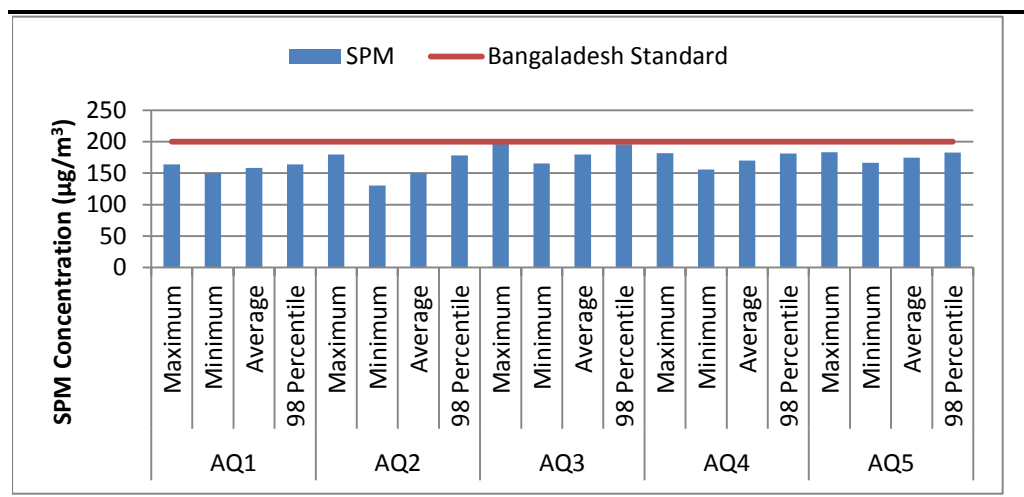
Note:

- \* CO concentrations and standards are 8-hourly only.
- \*\* The Bangladesh National Ambient Air Quality Standards have been taken from the Environmental Conservation Rules, 1997 which was amended on 19<sup>th</sup> July 2005 vide S.R.O. No. 220-Law/2005.
- \*\*\* WHO Ambient Air Quality Guideline Values (2005 and 2000), which are also being referred in the World Bank and IFC's General EHS Guidelines (2007)

### Analysis and Discussion of Results

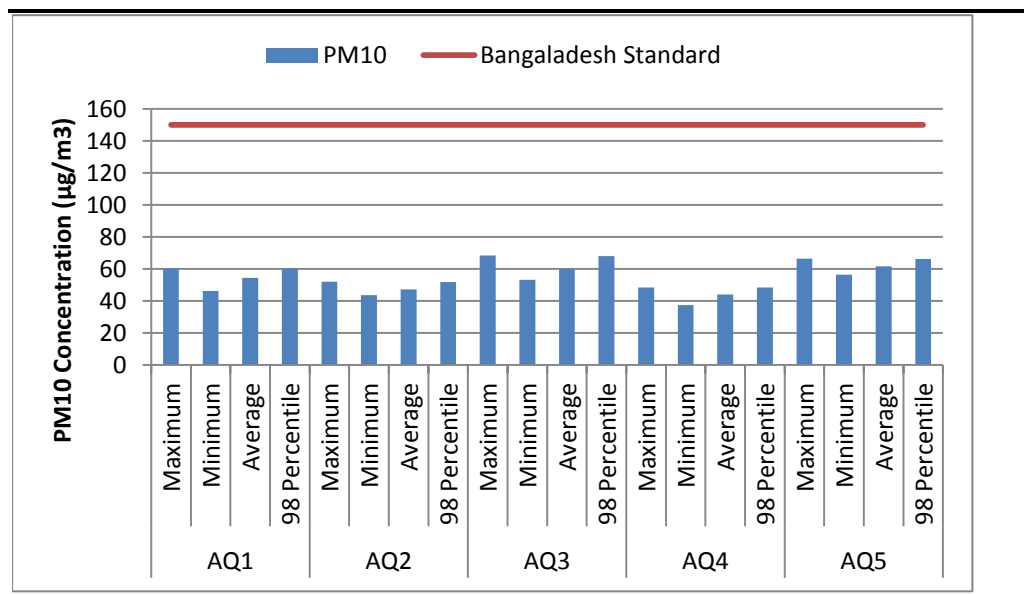
**SPM:** The 98<sup>th</sup> percentile SPM concentration at the five monitoring locations was recorded in the range of 164.03 – 182.91  $\mu\text{g}/\text{m}^3$ . The 24-hourly average SPM concentration in ambient air was recorded in the range of 150.29 – 179.57  $\mu\text{g}/\text{m}^3$ . The 24 hourly SPM concentrations in all the monitoring locations were with the National Ambient Air quality standard. During the monitoring period, the maximum SPM concentration was reported from AQ-3 as 179.57  $\mu\text{g}/\text{m}^3$ . Higher SPM concentrations at this location are primarily due to (a) unpaved road stretches, traffic movement and commercial activities. SPM level near to Project Site (AQ-1 and AQ-5) were reported below the below the National Ambient Air Quality Standards of Bangladesh, whereas, there is no specific standard prescribed by WHO for SPM.

Figure 4.24 SPM Concentration Pattern in the Project AOI



**PM<sub>10</sub>:** The 24-hourly average PM<sub>10</sub> concentration in ambient air in the study area was recorded in the range of 44.07 µg/m<sup>3</sup> at AQ-4 to - 61.71 µg/m<sup>3</sup> at AQ-5). The 98<sup>th</sup> percentile was recorded in the range of 47.35 µg/m<sup>3</sup> at AQ-2 to 66.20 µg/m<sup>3</sup> at AQ-5. The 24 hourly PM<sub>10</sub> concentrations in all the monitoring locations were within National Ambient Air Quality Standard (NAAQS) for PM<sub>10</sub> in Bangladesh. The PM<sub>10</sub> pattern in the study area has been presented in Figure 4.25. When the results are compared with the WHO guideline values for PM<sub>10</sub>, it was noted that at all locations the air quality is well within the stipulated guideline value.

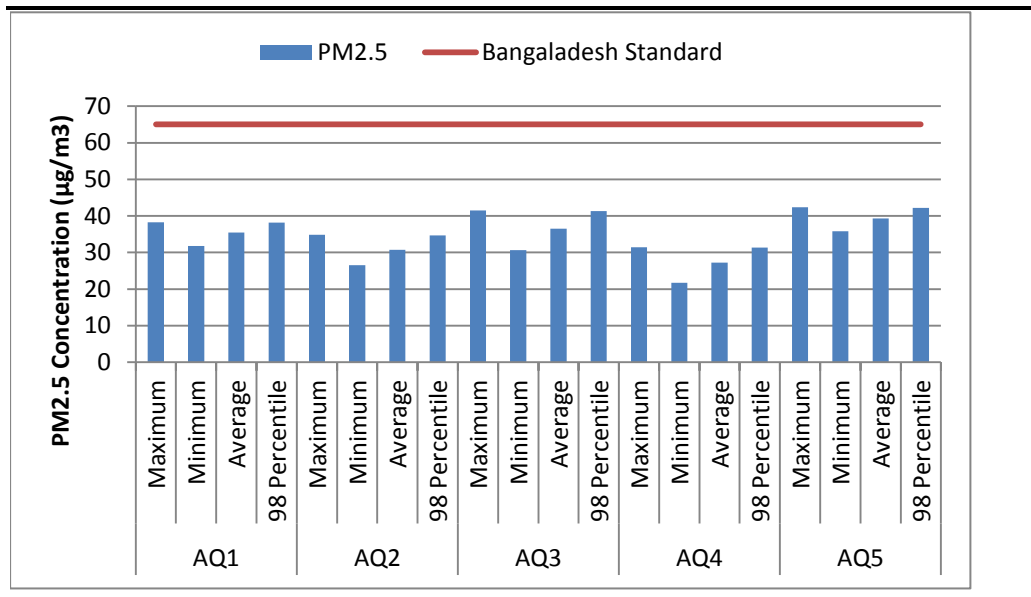
Figure 4.25 PM<sub>10</sub> Concentration Pattern in the Project AOI



**PM<sub>2.5</sub>:** The 24-hourly average PM<sub>2.5</sub> concentration in ambient air in the study area was recorded in the range of 27.25 µg/m<sup>3</sup> at AQ-4 to - 39.30 µg/m<sup>3</sup> at AQ-5). The 98<sup>th</sup> percentile was recorded in the range of 31.35 µg/m<sup>3</sup> at AQ-4 to 42.24 µg/m<sup>3</sup> at AQ-5. The 24 hourly PM<sub>2.5</sub> concentrations in all the monitoring locations were within National Ambient Air Quality Standard (NAAQS) for PM<sub>10</sub> in Bangladesh. The PM<sub>2.5</sub> pattern in the study area has been presented in

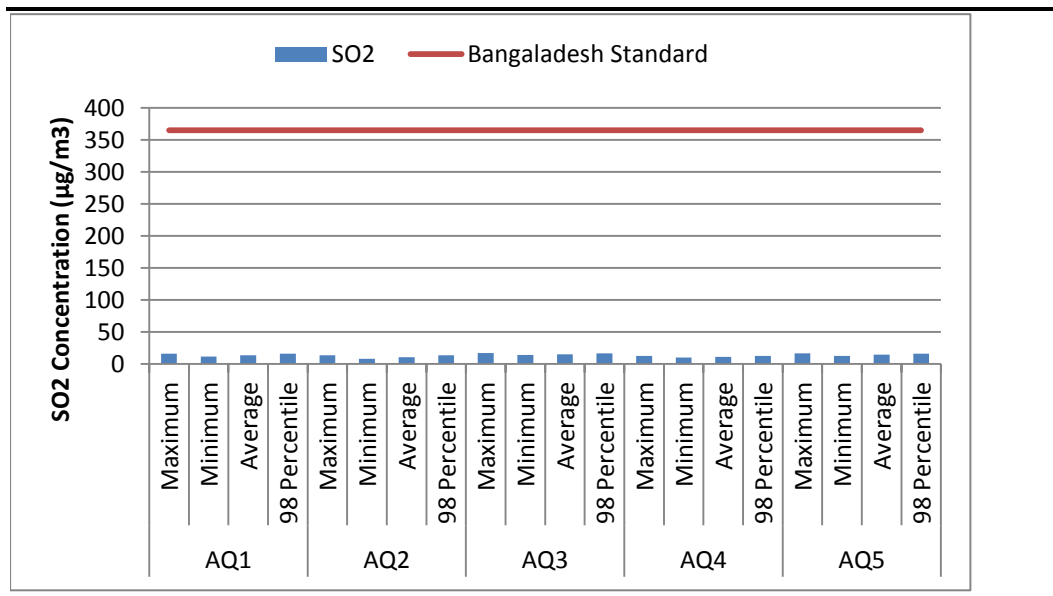
Figure 4.26. When the results are compared with the WHO guideline values for PM<sub>2.5</sub>, it was noted that in all the monitoring location were higher compared to WHO guideline values for PM<sub>2.5</sub>.

Figure 4.26 *PM<sub>2.5</sub> Concentration Pattern in the Project AOI*



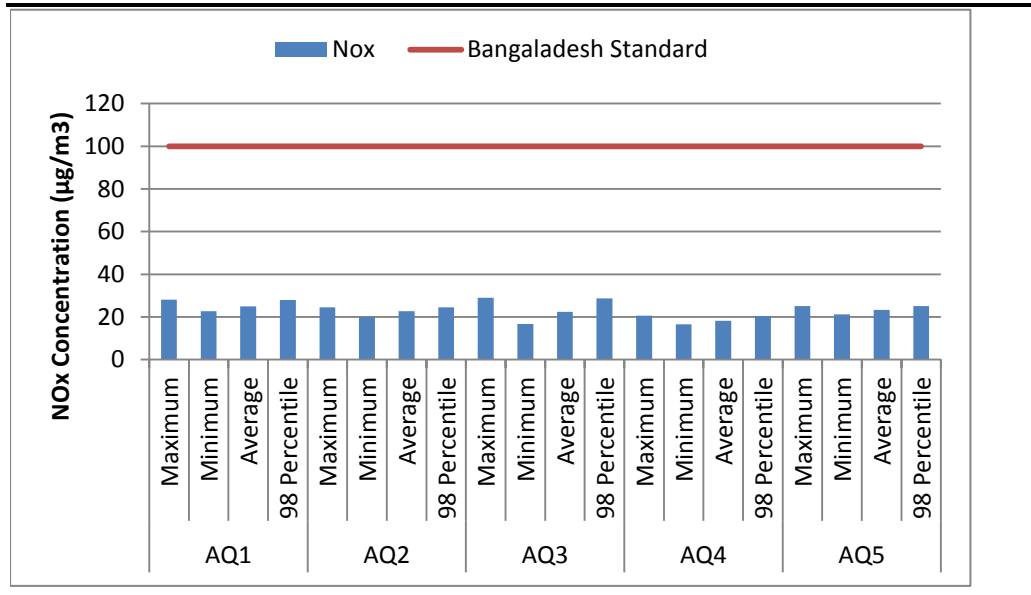
SO<sub>2</sub>: The 24-hourly average SO<sub>2</sub> concentration in ambient air in the study area was recorded in the range of 10.79 µg/m<sup>3</sup> at AQ-2 to - 15.17 µg/m<sup>3</sup> at AQ-3. The 98<sup>th</sup> percentile was recorded in the range of 12.51 µg/m<sup>3</sup> at AQ-4 to 16.39 µg/m<sup>3</sup> at AQ-5. The 24 hourly SO<sub>2</sub> concentrations in all the monitoring locations were within National Ambient Air Quality Standard (NAAQS) for PM<sub>10</sub> in Bangladesh. The SO<sub>2</sub> pattern in the study area has been presented in *Figure 4.27*. When the results are compared with the WHO guideline values for SO<sub>2</sub>, it was noted that in all the monitoring location were higher compared to WHO guideline values for SO<sub>2</sub>.

Figure 4.27 *SO<sub>2</sub> Concentration Pattern in the Project AOI*



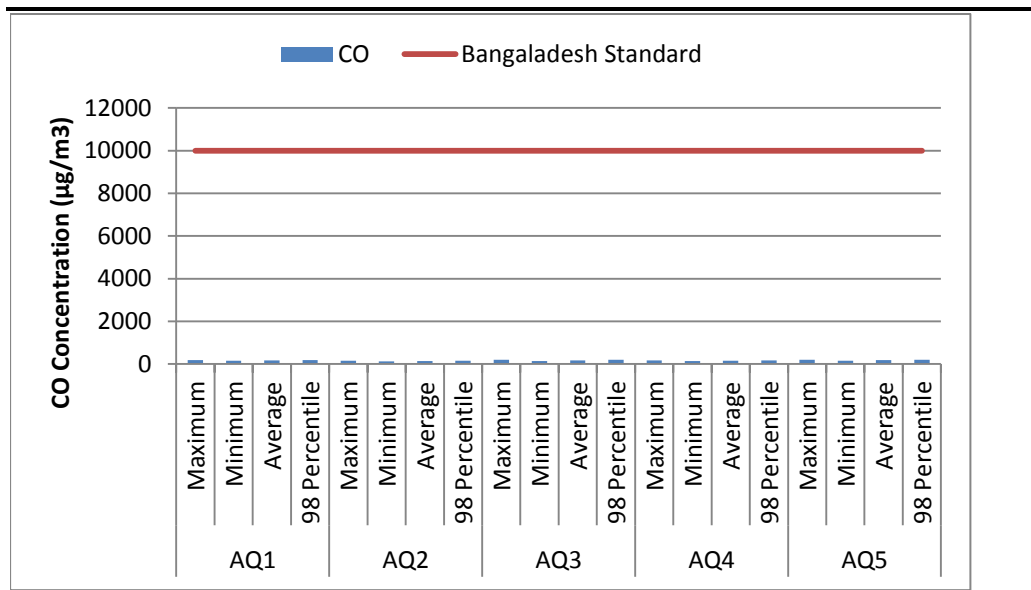
**NO<sub>x</sub>:** The 24-hourly average NO<sub>x</sub> concentration was recorded in the range of 18.20 µg/m<sup>3</sup> (AQ-4) to 24.89 µg/m<sup>3</sup> (AQ-1). The 98<sup>th</sup> percentile was recorded in the range of 20.43µg/m<sup>3</sup> (AQ-4) to 27.95 m<sup>3</sup> (AQ-1). The NO<sub>x</sub> pattern in the study area has been presented in **Figure 4.28**. There are no stipulated standards for 24-hourly NO<sub>x</sub> concentration in Bangladesh. The annual Bangladesh standard for NO<sub>x</sub> is 100 µg/m<sup>3</sup> and present 24 hourly average concentrations at all the locations are well below these values.

**Figure 4.28** NO<sub>x</sub> Concentration Pattern in the Project AOI



**CO:** The 8-hourly average CO concentration was recorded below the detection limits or ranged up to maximum of 180µg/m<sup>3</sup>. The 98<sup>th</sup> percentile was recorded in the range of 158.80- 2199.20µg/m<sup>3</sup>. Average concentrations of CO are reported low at all the monitoring locations while comparing with the Bangladesh Standards (10 mg/m<sup>3</sup>). The CO pattern in the study area is presented in **Figure 4.29**.

**Figure 4.29** CO Concentration Pattern in the Project AOI



### Conclusion

It is evident from the above comparison of ambient air quality results with the applicable standards that the ambient air quality of the project AOI is good with respect to the gaseous pollutants and fine particulate matter (PM<sub>2.5</sub>). Industrial activity in the area is currently limited to the operational 225 MW power plant of Bhola I and few brick-kilns. The AOI is not a degraded airshed.

#### 4.3.10 Ambient Noise Levels

Noise levels were recorded at nine locations in the study area during the monitoring period. Noise levels were recorded in the form of sound pressure levels using a digital sound level meter with data logger. The details of noise monitoring locations are given in *Table 4.16* and depicted in *Figure 4.23*.

**Table 4.16** Details of Ambient Noise Monitoring Locations

S.N.	Location Code	Distance from Project Boundary	Direction from Project Boundary	Geographical Location	Location Setting
1	NQ1	120 m	E	22°28'50.59"N 90°42'43.84"E	Residential area
2	NQ2	10 m	-	22°28'47.80"N 90°42'41.10"E	Industrial area
3	NQ3	150 m	N	22°28'53.70"N 90°42'34.70"E	Residential area
4	NQ4	50 m	E	22°28'37.80"N 90°42'48.20"E	Residential area
5	NQ5	Within Power Complex	-	22°28'39.30"N 90°42'42.60"E	Industrial area
6	NQ6	Within Power Complex	-	22°28'39.10"N 90°42'33.91"E	Industrial area
7	NQ7	Boundary of Power Complex	N	22°28'48.40"N 90°42'32.87"E	Industrial area
8	NQ8	220 m	SW	22°28'29.30"N 90°42'32.00"E	Village setting
9.	NQ9	400 m	NW	22°28'55.10"N 90°42'18.10"E	Village setting

The purpose of ambient noise level measurement was to determine sound intensity at the monitoring locations. These locations are chosen in such a way that representative data could be recorded all over the block. The sound level is recorded in form of A-weighted equivalent continuous sound pressure level (Leq) values with the use of A-weighting filters in the noise measuring instrument.

Noise level monitoring was carried out for 24 hours during monitoring period with 1-min equivalent sound pressure levels. At all the locations, measurement was taken at 1-min intervals over a 24 hour period. The equivalent noise levels have been converted to hourly equivalent noise levels. Finally, the measurements were carried out by dividing the 24 hours into two parts, i.e. daytime, which is considered from 0600 to 2100 hours and night from 2100 to 0600 hours. At each location, day time Leq has been computed

from the hourly sound pressure level values measured between 0600 to 2100 hours and night time Leq has been computed from the hourly sound pressure level values measured between 2100 to 0600 hours.

#### Observations

The recorded noise levels in the Project AOI during April 2016 are summarised in *Table 4.17*. The equivalent sound pressure level (Leq) during day and night time measured during the monitoring period is presented in *Figure 4.30*.

**Table 4.17** Noise Levels in the Study Area, (January – February 2013)

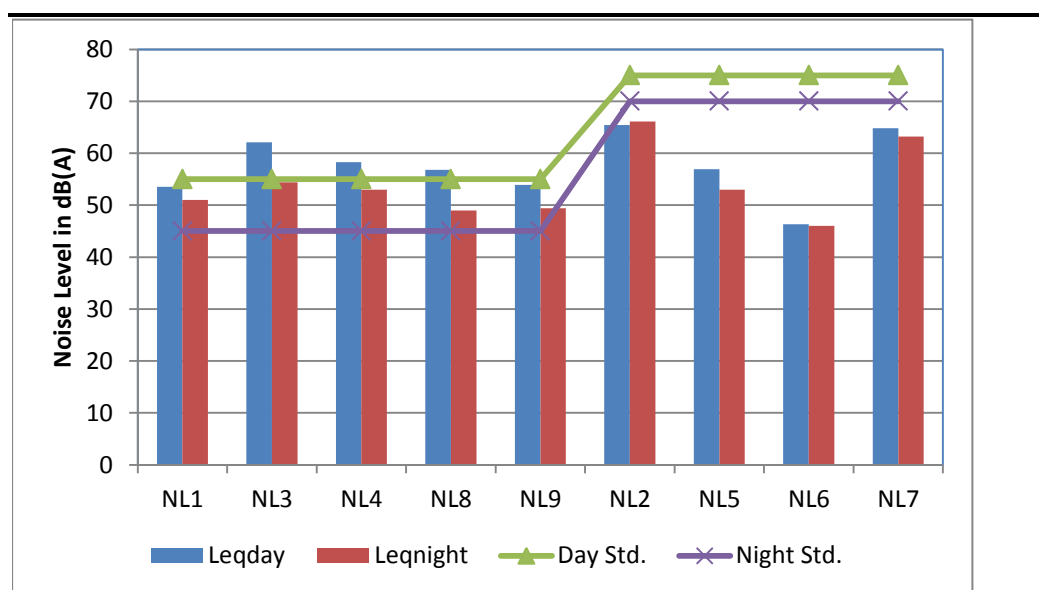
Locations	Noise level (dB(A))				Applicable Standard (dB(A))* as per Landuse	
	Leq <sub>day</sub>	Leq <sub>night</sub>	L <sub>max</sub>	L <sub>min</sub>	Day	Night
NL1	53.5	51.0	69.4	46.2	55	45
NL2	65.4	66.1	77.9	59.0	75	70
NL3	62.1	54.4	84.1	47.5	55	45
NL4	58.3	53.0	75.8	43.2	55	45
NL5	56.9	53.0	75.8	45.9	75	70
NL6	46.3	46.0	54.1	40.2	75	70
NL7	64.8	63.2	79.4	53.6	75	70
NL8	56.8	49.0	72.2	40.0	55	45
NL9	53.9	49.4	63.2	42.5	55	45

Note: The time from 0600 hrs. to 2100 hrs. is counted as daytime and from 2100 hrs. to 0600 hrs. is counted as night time.

Source: Environmental Conservation Rules, 1997 (Schedule 4) amended September 7, 2006

Ambient daytime noise level (**Leq<sub>day</sub>**) was recorded in the range of 46.3 to 65.4dB (A). Whereas, ambient night time noise level (**Leq<sub>night</sub>**) in the study area varied in the ranged of 46.0 to 66.1 dB (A). Maximum noise levels (**L<sub>max</sub>**) at the monitoring locations were recorded in the range of 54.1 to 84.1 dB(A) and the minimum noise levels (**Leq<sub>min</sub>**) at the monitoring locations were recorded in the range of 40.0 to 59.1 dB(A).

**Figure 4.30** Noise Levels Recorded in the Study Area



## Conclusion

Bhola I power plant is now operating plant, the noise levels around the power complex boundary when compared to the prescribed limits for industrial landuse was well within the limits. Noise monitoring locations (NL1, NL3, NL4, NL8 and NL9) are located in the rural settings, the noise levels in these locations when compared to prescribed limits for residential landuse were higher than the the day time noise standard except NL1 and NL9. The night time noise levels in all the monitoring location were above the noise standard for residential landuse. The noise levels at rural setting were recorded higher compared to residential landuse primarily due to anthropogenic activities, traffic movement and also attributed due to noise generated by the insects and other fauna, due to dense homestead plantation in the village setting.

### 4.3.11 Traffic

The current traffic (Road and River) assessment was identified for two locations in the Project AOI, which are connected to the Project Site. The traffic assessment locations were selected based on discussions with the client and survey of main access roads which will provide connectivity to the Project for transportation of manpower and materials. The two location details are provided in **Table 4.18**. For the other location i.e. access road to the Project site, the traffic volume was monitored continuously for 24 hours, one time, during the study period.

**Table 4.18** Locations of Traffic Survey

S N	Location Code	Geographical Coordinates/ Location	Location detail and justification
1	TD1	Site Approach Road 22°28'44.86"N 90°42'56.41"E	Assess the traffic load in the site approach road
2	TD2	22°29'20.86"N 90°42'30.50"E	Assess the river traffic to project site

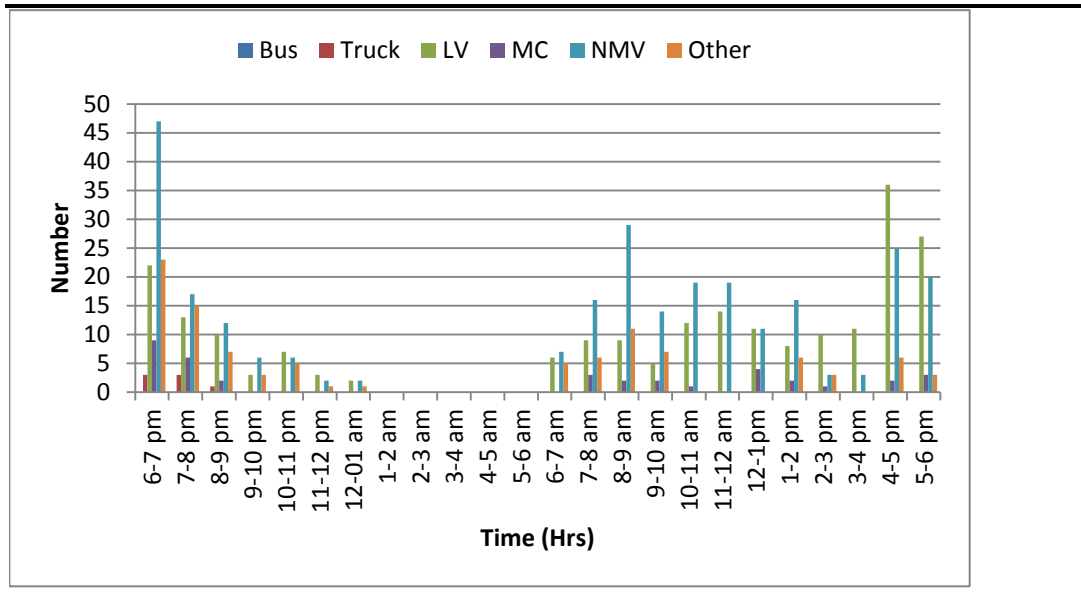
### Road Traffic

The maximum number of vehicles were non-motorized (42.9%) followed by light vehicle (34.2%) and others (16.0%). Percentage of heavy vehicles is very low only 1.1% of the total traffic. The hourly traffic variation in the access road connecting the Project site is shown in **Figure 4.31**.



**Figure 4.31** Traffic Volume in the access road connecting the Project site

LV-Light Vehicle, MC-Motor Cycle, NMV- Non-motorized Vehicles, Others-battery operated rickshaws

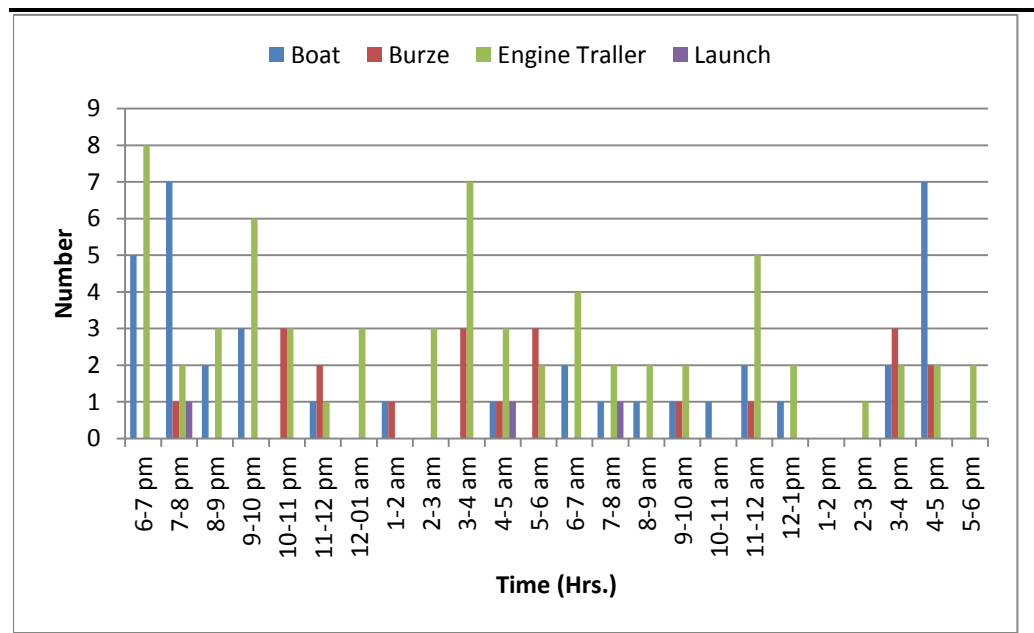


& CNG

*River Traffic*

The maximum number of river traffics were Engine traller (51.2%) followed by Boat (29.9%), Burze (16.5%) and Launch (2.4%). The hourly river traffic variation in the access road connecting the Project site is shown in Figure 4.32.

**Figure 4.32** River Traffic in Dehular Canal



## 4.4 NATURAL CAPITAL - ECOLOGY

### 4.4.1 Introduction

The ecological survey of the project site and area of Influence (AOI- 3.5 km radial area from project site centre) were surveyed from April 13<sup>th</sup> 2016 to April 17<sup>th</sup> 2016 to assess the baseline ecological conditions in the AoI and the likely impacts of project construction and operation activities on them. The study was undertaken with following objectives;

#### *Floral Assessment*

- Assess the status of major floral components (Trees, shrubs, herbs, grass and climbers) within the AoI (core area -Project Site and buffer areas 3.5 km radius from the Project Site centre) ;
- Preparation of Floral Biodiversity Index for floral component across the habitat/ecosystems of the AoI ;
- Collection and compilation of secondary information on the status of floral components of different vegetation types in the AoI; and
- Identification, listing and quantification of floral species of conservation significance (Endangered species) in accordance with Global IUCN, 2016 ver.3 and IUCN Bangladesh. 2015 along with Wildlife (Conservation and Security) Act, 2012 of Bangladesh.

#### *Faunal Assessment*

- Assess the status of major faunal groups (Fishes, Amphibians, Reptiles, Terrestrial and Aquatic birds and Mammals) within the AoI;
- Collection and compilation of secondary information on the status of faunal components located in the AoI; and
- Identification, listing and quantification of faunal species of conservation significance (Rare, Endangered and Threatened (RET) species) in accordance with Global IUCN, 2016 ver.3 and IUCN Bangladesh. 2015 along with Wildlife (Conservation and Security) Act, 2012 of Bangladesh. within the AoI.

### 4.4.2 Approach and Methodology

The study was undertaken in the summer season in the month of April in order to establish an ecological baseline. A reconnaissance survey of entire AoI was carried out to understand the existing biological environment and different land use/land cover of the core and buffer area. Review of secondary literature available on the AoI was also undertaken.

### 4.4.3 Delineation of Area of Influence

The AoI was delineated into two zones

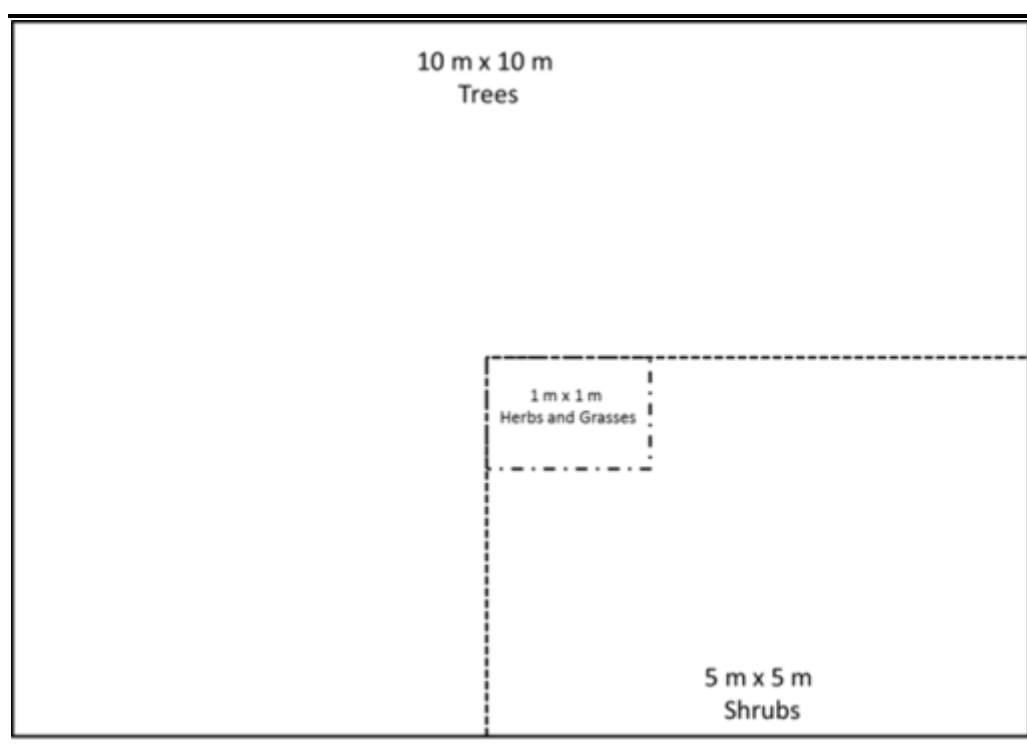
**Core Zone:** It includes the area of the identified plot about 11.5 acres, additional land requirement of 5.78 acres for plant and access road and 5.5 acres for ROW of 6 km long gas pipeline.

**Buffer Zone:** The buffer zone includes area within 3.5 km radius from the project site center. This area includes various habitats such as homestead plantations, water bodies such as village ponds and Dehular Khal, agricultural land and riverine habitats. Following methodology was adopted to enumerate the floral and faunal species in AoI.

*Methodology for Vegetation Assessment*

The vegetation within the AoI was enumerated by undertaking random sampling in different identified habitats. Terrestrial habitats such as homestead plantation and agricultural land was surveyed within a sampling plot for trees (10m x 10m), shrubs(5m x5m ), herbs and grasses(1m x1m). A total of 8 such sampling plots were surveyed in different identified habitats. A sampling plot is represented in *Figure 4.33*.

**Figure 4.33** *Description of Sample Plot*



Plankton Sampling was undertaken at 4 location in Dehular Khal to enumerate the Phyto and Zoo Planktons in water body. The location of sampling plots area given in *Table 4.19* and represented in *Figure 4.34*.

**Table 4.19** *Location of Ecological Sampling Stations*

Sn	Sampling Habitat Station	Latitude	Longitude	Aerial Distance and Direction from Project Site Centre
<i>Terrestrial Vegetation Sampling</i>				

Sn	Sampling Station	Habitat	Latitude	Longitude	Aerial Distance and Direction from Project Site Centre
1.	E1	Homestead Plantation	22°28'52.76"N	90°42'43.20"E	395 m -ENE
2.	E2	Agricultural Land	22°28'33.75"N	90°42'49.47"E	652 m-SE
3.	E3	Homestead Plantation	22°28'49.19"N	90°42'52.37"E	604 m-E
4.	E4	Homestead Plantation	22°28'44.60"N	90°40'52.87"E	2.8 km-W
5.	E5	Homestead Plantation	22°27'36.62"N	90°40'57.63"E	3.4 km-SW
6.	E6	Agricultural Land	22°28'22.99"N	90°42'22.54"E	740 m-SSW
7.	E7	Agricultural Land	22°28'40.36"N	90°42'26.19"E	190 m-SW
8.	E8	Agricultural Land	22°28'37.75"N	90°43'56.02"E	2.4 km-E
Plankton Survey Locations					
1.	PK1	Dehular Khal	22°28'47.40"N	90°40'41.90"E	3.2 km-W
2.	PK2	Dehular Khal	22°29'22.87"N	90°42'14.94"E	1.4 km-NW
3.	PK3	Dehular Khal	22°29'6.12"N	90°42'30.33"E	590 m-N
4.	PK4	Dehular Khal	22°28'26.10"N	90°42'40.50"E	650 m-SSE

Source: ERM Ecological Survey, 13<sup>th</sup> -17<sup>th</sup> April 2016

### *Methodology for Faunal Survey*

#### Fishes

Fishery resources from the AoI were enumerated based on fisherman survey and fish market survey at Burhanuddin Town, Kunjerhat Bazar Road-Upozila road junction and another fish market across the Dehular Khal Bridge. Based on the discussion local names of the species were noted, their breeding season was also recorded.

#### Herpetofauna

Herpetofaunal species includes Amphibians and Reptiles were enumerated based on primary survey and secondary information through published literature. Intensive search was made along the hedges of all the aquatic habitats open wells located in the study area were checked to identify and list the amphibians. Status of reptiles was assessed using Intensive Time Constrained Search Methods <sup>(1)</sup> <sup>(2)</sup> covering different micro habitats surveyed within the core and buffer zones of the study site.

#### Avifauna

Avifaunal species were enumerated by habitat surveys at the sample plots. Avian nomenclature was followed by Standard field guide <sup>(3)</sup>.

#### Mammals

(1) Welsh, H.H., jr. 1987. Monitoring herpetofauna in woodlands of north western California and south west Oregon: a comparative strategy. Pp. 203-213. In. Multiple - Use Management of California's hardwood resources. T.R. Plumb, N.H. Pillsbury (eds. Gen. Tech. Regional Environmental Planning, PSW - 100) US Department of Agriculture, Forest Service.

(2) Welsh, H.H. Jr. and Lind, A. 1991. The structure of the herpetofaunal assemblage in the Douglas-fir/hardwood forests of northwestern California and south western Oregon. Pp: 395-411. In: Wildlife and vegetation of unmanaged Douglas-fir forests. (Tech.Coords). L.F. Ruggiero, K.B. Aubry, A.B. Carey and M.H. Huff. Ge. Tech. Rep. PNW-GTR-285. Portland, OR: US. Department of Agriculture, Forest Service.

(3) Birds of India, Srilanka, Pakistan, Nepal, Bhutan, Bangladesh and Maldives. 2000. Krys Kazmeierczak and Ber Van Perlo. Om Field Guides

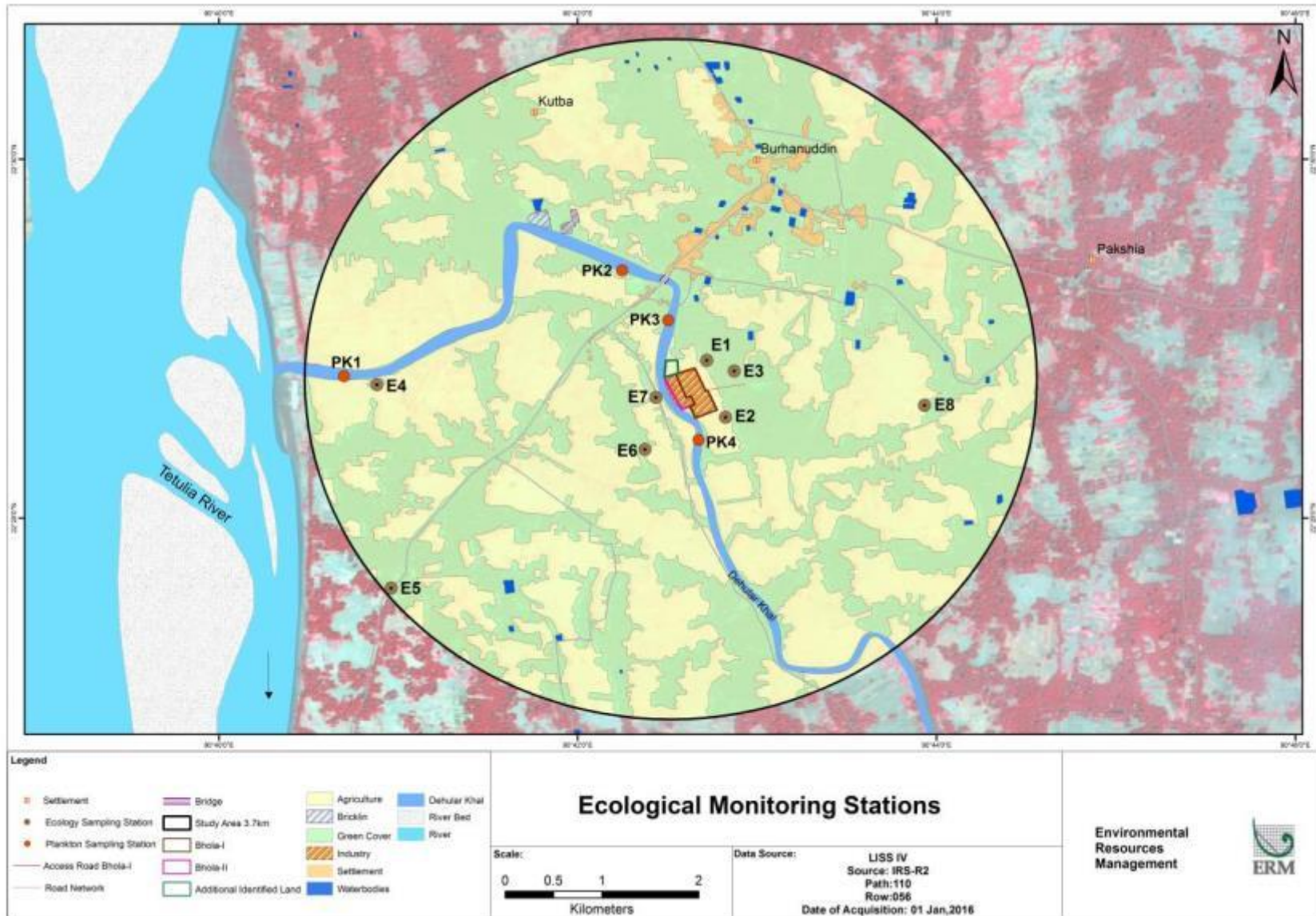
Habitat survey for mammals was conducted. Identification was followed by standard literature. <sup>(1)(2)</sup>

Secondary literature from published books and research publications were also consulted for the flora and fauna of the study area. Discussions were held with the officials of State Forest department. The enumerated list of faunal species is compared to the species listed in IUCN Red data list for Bangladesh along with IUCN global and species listed in schedule of Wildlife (Conservation and Security) Act, 2012 of Bangladesh. to confirm their conservation status.

(1) Prater. S. H. 2005. The Book of Indian Animals. Bombay Natural History Society and Oxford University press 12th Edn. pp. 316.

(2) Menon, V. 2003. A field guide to Indian Mammals. Dorling Kindersley (India) Ltd. New Delhi. 201 p.

Figure 4.34 Map showing location of Sampling Stations



#### 4.4.4

### Terrestrial Environment

#### Vegetation Classification

The AoI fall under Offshore Island (8b) as classified by IUCN Bangladesh into 25 Bio-ecological Zones in Bangladesh in the context of physiographic and biological diversity. The Bhola Island falls under the bio-ecological zone of 'Offshore Islands (8b)' Details on this bioecological zone is presented in **Box 4.1** and **Figure 4.35**.

#### Box 4.1

#### Offshore Islands (8b)

<b>Location</b>	:	21°35'-22°45' N and 90°15'-92°05' E
<b>Relevant Adm HQ</b>	:	Cox's Bazar, Bhola, Patuakhali, Noakhali
<b>Physiography</b>	:	Young Meghna estuarine floodplain; Chittagong coastal plain
<b>Soil</b>	:	Calcareous alluvium (saline); Acid sulphate soils; Brown hill soils
<b>Rainfall</b>	:	2290-2790 mm
<b>Temperature</b>	:	Maximum 34° C, Minimum 12° C
<b>Flooding depth</b>	:	Medium Highland
<b>Land use</b>	:	Fallow-Fallow-T. aman (5b); Rabi-Aus-T. aman (2b); Planted Mangrove forest (15b)
<b>Floral diversity:</b>		
<b>Trees</b>		
Narikel ( <i>Cocos nucifera</i> ), Supari ( <i>Areca catechu</i> ), Rendi koroi/Rain tree ( <i>Samanea saman</i> ), Bhadi ( <i>Lannea coromandelica</i> )		
<b>Aquatic plants</b>		
Topapana ( <i>Pistia strateotes</i> ), Kolmi ( <i>Ipomoea aquatica</i> ), Jhanji ( <i>Utricularia exoleata</i> )		
<b>Faunal diversity:</b>		
<b>Mammals</b>		
<b>Bengal fox (<i>Vulpes bengalensis</i>), Fishing cat (<i>Prionailurus viverrinus</i>), Common palm civet (<i>Paradoxurus hermaphroditus</i>), Ganges river dolphin (<i>Platanista gangetica</i>), Greater bandicoot rat (<i>Bandicota indica</i>)</b>		
<b>Birds</b>		
Indian skimmer ( <i>Rynchops albicollis</i> ), Purple heron ( <i>Ardea purpurea</i> ), Painted stork ( <i>Mycteria leucocephala</i> ), Eurasian thick-knee ( <i>Burhinus oedicnemus</i> )		
<b>Reptiles</b>		
River terrapin ( <i>Batagur baska</i> ), Glossy marsh snake ( <i>Gerardia prevostianus</i> )		
<b>Amphibians</b>		
Boulenger's frog ( <i>Rana alticola</i> ), Common toad ( <i>Bufo melanostictus</i> )		

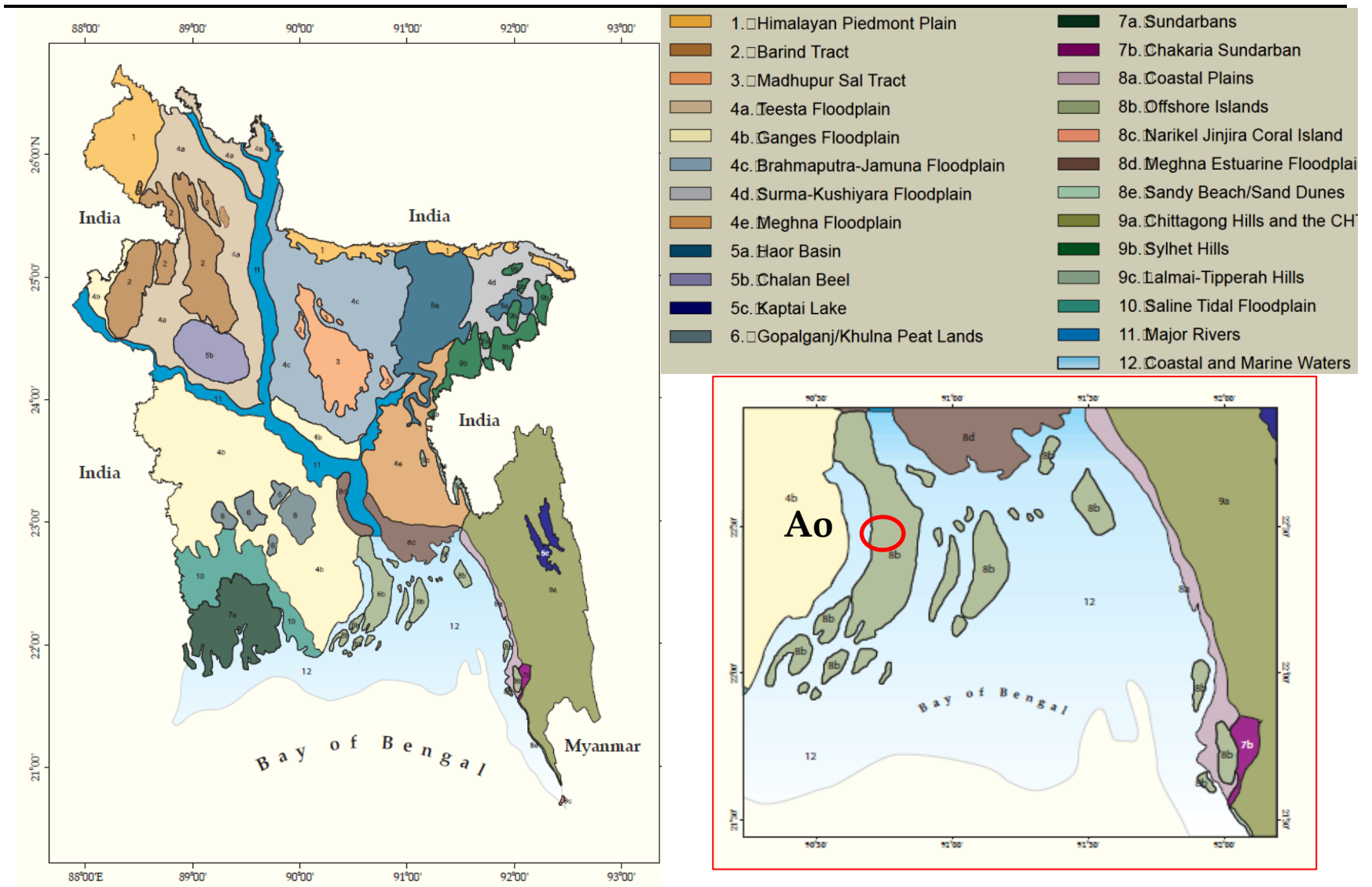
Source: Nishat A. Haq, S.M. Imamul, Barua Shuvashish, P. Reza Ali, A.H.M., Khan, Moniruzzaman, A.S. (eds) 2002. Bio-ecological Zones of Bangladesh. IUCN Bangladesh Country office, Dhaka, Bangladesh. xii+131pp. Source: Bioecological Zones of Bangladesh, IUCN, 2002

Note: Bengal fox and fishing cat (highlighted above) were found within the project AOI, whereas common palm civet, Ganges river dolphin and greater bandicoot rat were not found within the project AOI. Bengal fox is vulnerable whereas fishing cat is endangered species as per IUCN Bangladesh Status (2015).

This zone covers Bhola, Hatiya, Ghasiar char, Moulvir char, Shahebanir char, Char bata, Char kukri mukri, Nijhum dweep, etc. Shapes of most of the islands are continuously changing as a result of erosion and tidal insurgence. Moreover, there are extensive intertidal mudflats composing parts of the islands. Most of these mudflats occur along the inland creeks. There are also large shoals in this area; these may consolidate into large islands by the end of this century. The vast amount of sediment brought down by the Meghna made the estuary shallow for a considerable distance.



Figure 4.35 Bio-ecological Zones of Bangladesh



Source: Nishat A. Haq, S.M. Imamul, Barua Shuvashish, P. Reza Ali, A.H.M., Khan, Moniruzzaman, A.S. (eds) 2002. Bio-ecological Zones of Bangladesh. IUCN Bangladesh Country office, Dhaka, Bangladesh. xii+131pp. Source: Bioecological Zones of Bangladesh, IUCN, 2002

The vegetation in the interiors of the island is similar to that of the mainland and includes: the Sada koroi (*Albizia procera*), Shaora (*Streblus asper*), Gab (*Diospyros peregrina*), Babla (*Acacia nilotica*), Kadam (*Anthocephalus chinensis*), Banyan (*Ficus bengalensis*), Jam (*Syzygium* spp.), Mandar (*Erythrina indica*), Sonalu (*Cassia fistula*), Date palm (*Phoenix sylvestris*), Toddy palm (*Borassus flabellifer*), Coconut (*Cocos nucifera*) and various bamboo species

Besides, some of the common reptiles of the zone include: the Common garden lizard (*Calotes versicolor*), Common skink (*Mabuya carinata*), Bengal monitor (*Varanus bengalensis*), Yellow monitor (*V. flavescens*), Checkered keelback (*Xenochrophis piscator*), Binocellate cobra (*Naja naja*) and Spotted flapshell turtle (*Lissemys punctata*). Likewise, common mammalian species of this zone include: the Ganges river dolphin (*Platanista gangetica*), Jackel (*Canis aureus*), Small Indian mongoose (*Herpestes auropunctatus*), Clawless otter (*Aonyx cinerea*), Large Indian civit (*Viverra zibetha*) and Greater bandicoot rat (*Bandicota indica*).

#### *Available Habitats in Area of Influence Core Zone*

The core zone in the identified plot area of 11.5 acres land is highly disturbed and does not bear any natural vegetation. The area is currently used as dump yards for waste construction material, scrap and from BPDB existing power plant. It was also observed that the project site was Contractor Facility Area for existing Power Plant. Some weed commonly found in the buffer area can be seen growing at the project site. The additional land required (5.78 acres) is agricultural land. The vegetation along the gas pipeline route is primarily homestead. Photo representation of the Project site is given in **Figure 4.36**

**Figure 4.36** *Photo representation in Core Zone*

---

#### Identified Project Site





Addition Land



Source: ERM Ecological Survey, 13<sup>th</sup> -17<sup>th</sup> April 2016

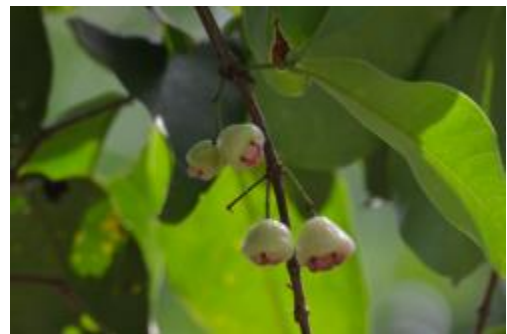
*Available Habitats in Area of Influence Buffer Zone*

The terrestrial vegetation is described based at habitat habitats available in the AoI. The identified habitats area are given below, representative photographs are provided in *Figure 4.37* and discussed further below

- a) Homestead Plantations
- b) Agricultural Lands

**Figure 4.37** *Major Habitat types Sampled in the Buffer Zone*

**Homestead Plantation**



*Syzygium samarangense*





**Agricultural Land**



**Riverine Vegetation**



Source: ERM Ecological Survey, 13<sup>th</sup> -17<sup>th</sup> April 2016

The floral species enumerated from the different habitats are described in below sections and presented in **Annex M**.

*Homestead Plantation*

Most of the houses are vegetated by local cultivated plants and a big portion of the coverage occupied by wild shrubs and herbs. A total of 72 species of trees, shrubs, herbs and grasses were enumerated. Common planted tree species are Raintree (*Samanea saman*), Aam (*Mangifera indica*), Supari (*Areca catechu*), Mehogani (*Swietenia mahagoni*), Kola (*Musa sp*) etc. Gogon Siris (*Albizia richrdiana*). Raintree (*Samanea saman*), Narikel (*Cocos nucifera*) and

Supari (*Areca catechu*) occupied the top canopy. Homesteads are commonly found near the wetland which favour good growth of wetland trees like Pitali (*Trewia nudiflora*), Baroon (*Crataeva nurvala*), Hizal (*Barringtonia acutangula*) etc. Among the shrubs Dumur (*Ficus hispida*) is the most common of all species. Isolated patches of Borassus palm (*Borassus flabelifer*) can also be seen along the riverine belt.

#### Agricultural Land

Paddy being the main agricultural crop in the AoI is the largest habitat available. Aman Rice is mono cultured all along the agricultural land along with some seasonal vegetables. A total of 26 species were enumerated from the AoI. The common weed occurring in the agricultural lands are *Ageratum conyzoides*, *Alternanthera sessilis*, *Clerodendrum inerme*, *Cotula hemispherica*, *Croton bonplandianum*, *Cynodon dactylon*, *Cyperus cephalotes*, *Dentella repens*, *Eupatorium odoratum*, *Euphorbia hirta*, *Heliotropium indicum*, *Nicotiana plumbaginifolia*, *Rorippa indica*, *Rumex dentate*, *Vernonia petula*.

The species enumerated from the AoI does not bear any species protected under Schedule IV of Wildlife (Conservation and Security) Act, 2012 of Bangladesh.

#### Terrestrial Faunal Species

##### Herpetofaunal Species

A total of 12 species of amphibians belonging to 5 families from the AoI were enumerated. Large Tree Frog (*Rhacophorus maximus*) is listed as Vulnerable as per IUCN 2016.v3 Red List of Threatened Species are species of conservational significance. Green Frog *Euphlyctis hexadactylus*, Indian Bull Frog *Hoplobatrachus tigerinus*, Two-striped Grass Frog *Hylarana taipehensis* are protected under Schedule I of Wildlife (Conservation and Security) Act, 2012 of Bangladesh. The list of amphibians is given in **Annex N**.

A total of 23 species of reptiles belonging to 9 families from the AoI. Red Crowned Roofed Turtle (*Batagur kachuga*), Gharial (*Gavialis gangeticus*) are listed Critically Endangered as per IUCN 2016, v3 Red List of Threatened Species are species of conservational significance. Spectacled Cobra (*Naja naja*) Monocled Cobra (*Naja kaouthia*), Bengal Monitor (*Varanus bengalensis*), Yellow Monitor (*Varanus flavescens*) South Indian Roofed Turtle (*Pangshura tentoria*) are listed as Near Threatened as per IUCN 2016, v3 Red List of Threatened Species is species of conservational significance. Presence of Juvenile Gharial (*Gavialis gangeticus*) was informed by local fishermen in Dehular Khal however, no direct sightings were made by ERM team. Red Crowned Roofed Turtle (*Batagur kachuga*) is also reported on the banks of Tentulia River during high flood season. Habitats for both the species does not coincide with AoI.

Out of listed 23 species 13 are protected under Schedule I of Wildlife (Conservation and Security) Act, 2012 of Bangladesh. The list of species are listed in *Annex O* and photographically presented in *Figure 4.38*.

**Figure 4.38** *Herpetofaunal Species in the AoI*



Yellow Monitor Lizard at BPDB Plant Boundary



Indian roofed turtle



Oriental Garden Lizard



Discussion with Snake-catcher regarding the snakes available in Area



Discussion with fisherman on Red Crowned Roofed Turtle on Tentulia River bank.

Source: ERM Ecological Survey, 13<sup>th</sup> -17<sup>th</sup> April 2016

### Avifaunal Species

A total of 53 species were enumerated in the AoI. Grey-headed Fish Eagle (*Ichthyophaga ichthyaetus*) listed as Near Threatened as per IUCN 2016, v3 Red List of Threatened Species is species of conservational significance. A total of 17 species are protected and are listed as Schedule I of the Wildlife (Conservation and Security) Act, 2012 of Bangladesh. The list of species are listed in *Annex P* and photographically presented in *Figure 4.39*.



Figure 4.39 Avifaunal Species in the AoI



Black Kite



Asian Pied Starling



Black Drongo



Red vented Bulbul



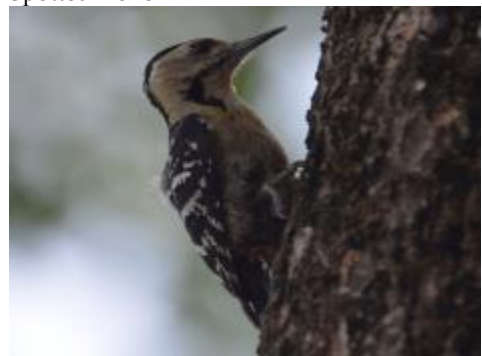
Black Headed Oriole



Spotted Dove



Common Kingfisher



Fulvous breasted Woodpecker



Spotted Owlet



Blue Rock Pigeon





House Sparrow



Baya Weaver



Large billed Cow



Chestnut tailed Starling



Orange headed Laughing Thrush



Oriental Magpie Robin



Jungle Myna



Stork billed Kingfisher



Great Egret

Source: ERM Ecological Survey, 13<sup>th</sup> -17<sup>th</sup> April 2016

### Mammalian Species

A total 21 species were enumerated from AoI. Fishing Cat *Felis viverrina* and Smooth-coated Indian Otter *Lutra perspicillata* listed as Vulnerable as per IUCN 2016, v3 Red List of Threatened Species is species of conservational significance. Out of 21 species 13 species are protected and are listed as Schedule I of the Wildlife (Conservation and Security) Act, 2012 of Bangladesh. The list of species are listed in *Annex Q* and photographically presented in *Figure 4.40*.

**Figure 4.40** *Mammal Species in AoI*



Jackal at the Approach Road to Power Plant Complex

Source: ERM Ecological Survey, 13<sup>th</sup> -17<sup>th</sup> April 2016

### **4.4.5** *Aquatic Environment*

#### *Aquatic Vegetation*

The aquatic and semi aquatic vegetation can be found in habitats such as riverine habitats and village ponds.

#### Riverine habitats and Village Ponds

A total of 41 species were enumerated from riverine habitat and village ponds. The riverine vegetation is predominantly *Colocasia esculenta*, *Eichhornia crassipes*, *Hygroryza aristata*, *Vetiveria zizanioides*, *Phragmites karka*. The banks are prone to erosion and flooding.

The village ponds are mostly used for bathing, washing clothes and fish culture. The dominant vegetation seen are *Alternanthera philoxioides*, *Azolla pinnata*, *Colocasia esculenta*, *Fimbristylis milliacea*, *Ipomoea aquatic*, *Lemna perpusilla*, *Monochoria hatata*, *Nymphaea nouchali*, *Nymphaea stellate*, *Nymphoides indicum* and *Wolffia microscopica*.

#### *Aquatic Planktons*

A total of four plankton sampling points were selected all along the mouth of Dehular Khal to little ahead of the Power Plant complex area to understand

the planktonic baseline of the channel. The location of the sampling locations are discussed in *Table 4.19*. Grab sampling were under taken using planktonic nets. Twenty five(25) liters of the surface water was passed through the planktonic net of mesh size 60 micron. The concentrated sample thus collected was fixed using adequate preservatives for phyto and zooplanktons and carried to laboratory for planktonic analysis. The photo-representation of the planktonic sampling are given in *Figure 4.41* and results are provided in *Table 4.20*.

**Figure 4.41** *Planktonic Sampling in AoI*



Source: ERM Ecological Survey, 13<sup>th</sup> -17<sup>th</sup> April 2016

**Table 4.20** *Abundance of Phytoplanktons and Zooplanktons*

Sn	Family/Group	Genera	PK1	PK2	PK3	PK4
<b>Phytoplanktons</b>			<b>Number (individuals/100L)</b>			
1.	Bacillariophyceae	<i>Cheatoceros</i>	8 X 10 <sup>3</sup>	11 X 10 <sup>3</sup>	4 X 10 <sup>3</sup>	2 X 10 <sup>3</sup>
		<i>Thalassionema</i>	60 X 10 <sup>3</sup>	23 X 10 <sup>3</sup>	67 X 10 <sup>3</sup>	29 X 10 <sup>3</sup>
		<i>Ditylum</i>	19 X 10 <sup>3</sup>	17 X 10 <sup>3</sup>	11 X 10 <sup>3</sup>	14 X 10 <sup>3</sup>
		<i>Navicula</i>	46 X 10 <sup>3</sup>	30X 10 <sup>3</sup>	21 X 10 <sup>3</sup>	18 X 10 <sup>3</sup>
		<i>Synedra</i>	3 X 10 <sup>3</sup>	18 X 10 <sup>3</sup>	35 X 10 <sup>3</sup>	102 X 10 <sup>3</sup>
		<i>Cyclotella</i>	11 X 10 <sup>3</sup>	14 X 10 <sup>3</sup>	3 X 10 <sup>3</sup>	7 X 10 <sup>3</sup>
		<i>Coscinodiscus</i>	120 X 10 <sup>3</sup>	170 X 10 <sup>3</sup>	215 X 10 <sup>3</sup>	100 X 10 <sup>3</sup>
2.	Cyanophyceae	<i>Anabaena</i>	10 X 10 <sup>3</sup>	12 X 10 <sup>3</sup>	5 X 10 <sup>3</sup>	3 X 10 <sup>3</sup>
		<i>Nostoc</i>	-	1X 10 <sup>3</sup>	-	-
		<i>Oscillatoria</i>	18 X 10 <sup>3</sup>	16 X 10 <sup>3</sup>	9 X 10 <sup>3</sup>	12 X 10 <sup>3</sup>
3.	Chlorophyceae	<i>Chlorella</i>	1 X 10 <sup>3</sup>	7 X 10 <sup>3</sup>	6 X 10 <sup>3</sup>	3 X 10 <sup>3</sup>
		<i>Spirogyra</i>	6 X 10 <sup>3</sup>	10 X 10 <sup>3</sup>	14 X 10 <sup>3</sup>	14 X 10 <sup>3</sup>
		<i>Closterium</i>	7 X 10 <sup>3</sup>	7 X 10 <sup>3</sup>	7 X 10 <sup>3</sup>	7 X 10 <sup>3</sup>
		<i>Micrococcus</i>	2 X 10 <sup>3</sup>	4 X 10 <sup>3</sup>	1 X 10 <sup>3</sup>	7 X 10 <sup>3</sup>
<b>Zooplanktons</b>						
1.	<b>Rotifers</b>	<i>Brachionus</i>	15X 10 <sup>3</sup>	11 X 10 <sup>3</sup>	6 X 10 <sup>3</sup>	9 X 10 <sup>3</sup>
		<i>Asplancha</i>	1 X 10 <sup>3</sup>	3X 10 <sup>3</sup>	2 X 10 <sup>3</sup>	1 X 10 <sup>3</sup>
		<i>Philodina</i>	43	17	14	17

Sn	Family/Group	Genera	PK1	PK2	PK3	PK4
		<i>Hexartha</i>	1 X 10 <sup>3</sup>	2 X 10 <sup>3</sup>	2 X 10 <sup>3</sup>	-
2.	<b>Copepods</b>	<i>Nauplius</i> larvae	3 X 10 <sup>3</sup>	1 X 10 <sup>3</sup>	-	-
		<i>Copepodid</i> stage	2 X 10 <sup>3</sup>	3 X 10 <sup>3</sup>	1 X 10 <sup>3</sup>	2 X 10 <sup>3</sup>
		<i>Cyclops</i>	3 X 10 <sup>3</sup>	9 X 10 <sup>3</sup>	1 X 10 <sup>3</sup>	8 X 10 <sup>3</sup>
		<i>Mesocyclops</i>	4 X 10 <sup>3</sup>	3 X 10 <sup>3</sup>	2 X 10 <sup>3</sup>	1 X 10 <sup>3</sup>
		<i>Diaptomus</i>	3X 10 <sup>3</sup>	2X 10 <sup>3</sup>	1 X 10 <sup>3</sup>	1 X 10 <sup>3</sup>
3.	<b>Cladocerans</b>	<i>Bosmina</i>	4 X 10 <sup>3</sup>	1 X 10 <sup>3</sup>	7 X 10 <sup>3</sup>	6 X 10 <sup>3</sup>
		<i>Moina</i>	9 X 10 <sup>3</sup>	5 X 10 <sup>3</sup>	11 X 10 <sup>3</sup>	18 X 10 <sup>3</sup>
		<i>Daphnia</i>	12 X 10 <sup>3</sup>	16 X 10 <sup>3</sup>	11 X 10 <sup>3</sup>	9 X 10 <sup>3</sup>
4.	<b>Ostracods</b>	<i>Cypris</i>	1 X 10 <sup>3</sup>	2X 10 <sup>3</sup>	1 X 10 <sup>3</sup>	1 X 10 <sup>3</sup>

Source: ERM Ecological Survey, 13<sup>th</sup> -17<sup>th</sup> April 2016

The results show high abundance of phytoplankton's and zooplankton's in the Dehular Khal. The abundance indicates that there is a likelihood of good fish population in the Dehular Khal.

#### Fish Fauna

Fishes in the AoI were enumerated based on fisherman survey, fish market survey and boat surveys. Based on survey a total of 90 species were enumerated. The habitat identified are Tentulia and Meghna River, Dehular Khal and wetlands. Two-spot Barb (*Puntius ticto*) has been identified as Vulnerable species listed as per IUCN 2016, v3 Red List of Threatened Species is species of conservational significance. Details of species along with their conservation status is provided in *Annex R* and represented in *Figure 4.42*

**Figure 4.42** Fish Species in AoI based on Fish Market Survey







*Cyprinus carpio*



*Amblypharyngodon mola*



*Sperata aor*



*Oreochromis niloticus*



*Catla catla*



*Polynemus paradiseus*

Source: ERM Ecological Survey, 13<sup>th</sup> -17<sup>th</sup> April 2016

#### 4.4.6

#### *Protected Areas*

The AoI does not bear any protected areas as per Bangladesh regulations and International conventions. The project site and AoI does not bear any areas identified as Critical habitats include those areas either legally protected or officially proposed for protection, such as areas that meet the criteria of the World Conservation Union classification, the Ramsar List of Wetlands of International Importance, and the United Nations Educational, Scientific, and Cultural Organization's world natural heritage sites, Alliance for Zero Extinction (AZE) sites.

Nearest protected area is Char Kukri Mukri Island located at the southern tip of Bhola Island at a distance of 55 km aerial distance.

Important Bird Area (IBA) Ganges-Brahmaputra-Meghna delta (as shown in **Figure 4.43**) in Bangladesh (BD011) and identified as non breeding areas for Spoon-billed Sandpiper (Critical Endangered), Spotted Greenshank (Endangered) and Indian Skimmer (Vulnerable). The project site does not

impact any of these areas. The shoals between Patukhali and Bhola are largely isolated and undisturbed and known as wintering ground <sup>(1)</sup> for many migratory birds.

**Figure 4.43** *Ganges-Brahmaputra-Meghna delta in Bangladesh IBA (A1, A4i, A4iii)*



Source: BirdLife International (2017) Important Bird Areas factsheet: Ganges-Brahmaputra-Meghna delta. Downloaded from <http://www.birdlife.org> on 31/01/2017

Bangladesh falls under Central Asian Fly way and East Asian–Australasian Migratory Flyway and offshore islands can serve as a stop over to migratory birds from Central Asia to South Asia and Australia. As the study was undertaken in non-migratory season none of migratory species was observed.

A Critical Habitat Assessment was undertaken (*Annex S*) to identify presence of threatened species in the AoI and likelihood of impacts due to project activities.

(1) <http://www.thedailystar.net/backpage/haven-migratory-birds-198709>

## 5.1 INTRODUCTION

This section provides the socio-economic baseline conditions existing in the area of influence for the proposed NBBL power plant. Where relevant, the description of the socio-economic baseline has also taken into account the existence of the BPDB Power Plant that commenced operations in 2015.

The analytical framework for interpreting and assessing the baseline data refers to the sustainable livelihoods framework <sup>(1)</sup>, which focuses on putting people at the centre of development (refer *Figure 4.1*). The baseline therefore describes the interrelated resources and receptors, which in the livelihoods framework are termed as 'capital' across five broad areas of resource and receptors on which livelihoods depend, i.e. social capital, natural capital, economic capital, physical capital and human capital.

The data for the baseline was collected through a variety of primary and secondary sources, which have been discussed in detail in subsequent sections. The section below will provide an overview of survey results. Comparisons and correlations with secondary data such as Census 2011, district progress reports on agriculture, health, livelihood, education etc. have been used in conjunction with the survey results to provide a holistic overview of the existing socio-economic baseline conditions in the study area.

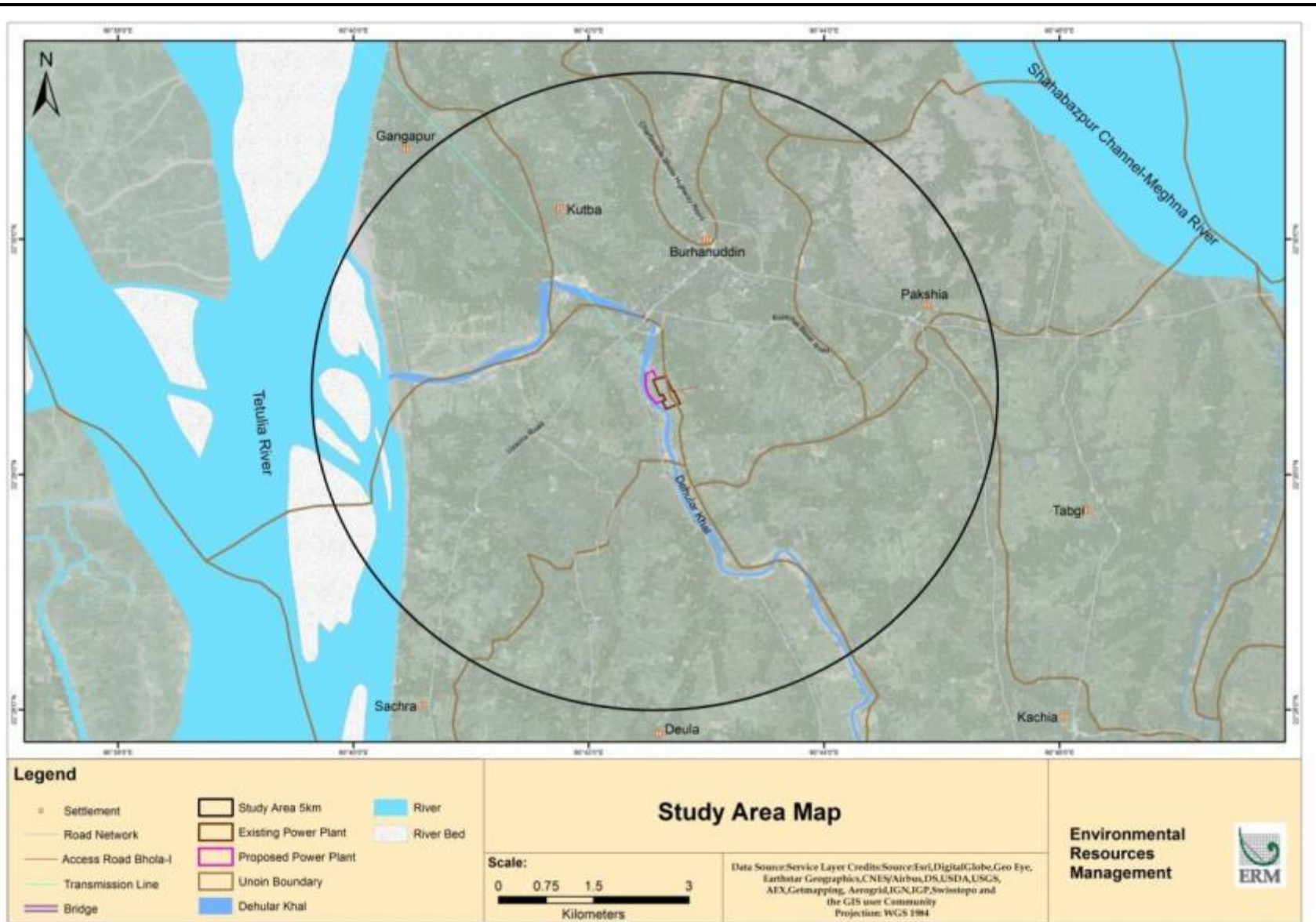
### 5.1.1 Study Area

The Project site is located at Kutba Village, Kutba Union of Burhanuddin Upazilla in Bhola District of Bangladesh. A location map of the project site is presented in Figure 5.1. The project site is situated on the left bank of Dehular Khal, beside an existing 225 MW combined cycle gas based power plant of the BPDB. Tetuliya River is located 4 km from the project location towards west. The nearest town is Burhanuddin, which is at a distance of 3 Km from the proposed project and Bhola Town or the district headquarter is about 28 km north (road distance). The study area for the socio-economic baseline was determined as area falling inside a radius of 5 km from the project location which would contain the main project set up and associated facilities, such as the gas pipeline up to the gas fields in Shahbazpur. The study area, thus, covers sections of the following unions of Burhanuddin Upazilla, Bhola District: Kutba; Kachia; Pakshia; Gangapur; Sachra; Deulia; Tabgi. *Figure 5.1* shows the extent of study area for the project.

(1) "A livelihood comprises the capabilities, assets (including both material and social resources) and activities required for a means of living. A livelihood is sustained when it can cope with and recover from stresses and shocks and maintain or enhance its capabilities and assets both now and in the future, while not undermining the natural resource base." (UK Department for International Development - DFID)



Figure 5.1 Study Area



The socio-economic baseline has been developed on the basis of integrating existing quantitative data with some additional qualitative assessments that were undertaken through primary data collection. In particular, the key components of the methodology included:

- **Household Survey:** Household survey of 206 families (approximately 20 from each of the above 10 villages) through a sampling strategy that takes into account the location of land owners and the route of the pipeline (*Annex T: List of Land Owners*); The household survey included coverage of the impacted land owners of Kutba Union and general population living in the study area based on a random sampling approach. The unions were selected based on the proximity to the project location so that details of villages located closer to the project location could be captured. Therefore, three villages each from Kachia and Kutba unions were selected. This was undertaken because of the project location in Kutba and location of route of gas pipeline which will pass through villages in Kachia Union. Other villages in other unions were selected as control group villages to comparatively ascertain baseline conditions in villages which are closer to project location and hence exposed to impacts from the project and villages which were relatively far from the project and hence, less exposed to potential impacts of the project.

The socio-economic household survey was undertaken from 5<sup>th</sup> January to 12<sup>th</sup> January 2017 and covered a total of 10 villages across five unions. A total of 207 households (total population amounting to 937 individuals) were surveyed and the breakup of survey as per villages covered is provided in table below:

**Table 5.1** *Coverage of Socio-Economic Survey*

Village	Union	Households
Dakshin Chota Monika	Kutba Union	19
Dakshin Kutba and Uttar Kutba	Kutba Union	24
Chhagla	Kutba Union	20
Bara Kachia Ward-1	Kachia Union	18
Kachia Ward-2	Kachia Union	22
Fullkachia	Kachia Union	20
Char Ghazipur	Sachra Union	20
Char Gangapur	Sachra Union	24
Choto Deula	Deula Union	20
Madhya Jaya	Gangapur Union	20
<b>Total</b>		<b>207</b>

Source: Socio-Economic Household Survey by ERM 2017

- **Thematic Areas for Focused Group Discussions:** Specific thematic areas were identified to capture consistent information across the Study Area. These themes were developed into a protocol for Focused Group Discussions (FGDs) that were undertaken at 10 locations across the Study Area. Qualitative Data Collection:

- a. Assessment of fishing livelihood patterns on Dehular Khal;
  - b. Discussions with stakeholder groups at the local community level on perceptions towards the projects, industrialisation, and livelihood patterns etc.
  - c. Discussions with land users/ owners, fishermen, women, traders in the study area; and
  - d. General expectations from the proposed project, in light of the development of the existing BPDB power plant.
- **Key Informant Interviews:** Interviews and meetings with government stakeholders at Burhanuddin Upazilla were undertaken to understand the regulatory processes, development schemes and upcoming plans in the study area:
    - a. Discussions with Government Departments, local authorities, etc., as required;
    - b. Discussion with local authorities involved in land acquisition and land procurement.

*Annex U* provides minutes of stakeholder consultations undertaken for the project.

*Figure 5.2* shows the locations where the household survey and FGDs were conducted:

Figure 5.2 Household Survey and FGD locations

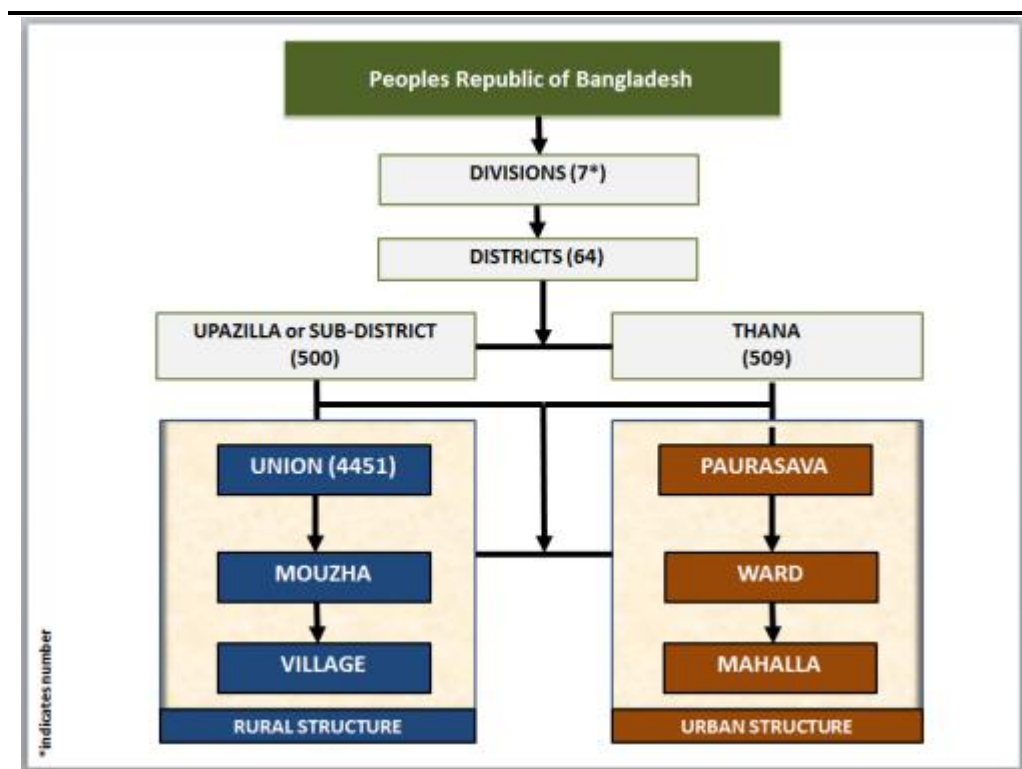


Source: ERM



Bangladesh is divided into 8 Divisions (Bibhag) and 64 Districts (Zila), although these have only a limited role in public policy. For the purposes of local government, the country is divided into Upazila, Union Councils, and Mauzas. The diagram below outlines the five tiers of government in Bangladesh:

Figure 5.3 Administrative Profile of Bangladesh



Source: Adapted from [www.bangladesh.gov.bd](http://www.bangladesh.gov.bd)

The project is located in Bhola District of Barisal division. Barisal is one of the eight administrative divisions of Bangladesh located in the south-central part of the country. It has an area of 13,644.85 km<sup>2</sup> and a population of 8,147,000 as per the 2011 Census. It is bounded by Dhaka division on the north, the Bay of Bengal on the south, Chittagong division on the east and Khulna division on the west. The division is subdivided into six districts (zilas) and into 39 sub-districts (upazilas). Lower level administrative areas are 353 union parishads, 3,159 mouzas, 12 municipalities, 25 wards and 4,163 villages.

Bhola District is one of seven districts within Barisal Division and it includes Bhola Island, the largest island of Bangladesh. It has an area of 3737.21 km<sup>2</sup> and a population of 1,776,795 as per 2011 Census. It is bounded by Lakshmipur and Barisal Districts to the north, the Bay of Bengal to the south, by Lakshmipur and Noakhali districts, the (lower) Meghna river and Shahbazpur Channel to the east, and by Patuakhali District and the Tetulia river to the west. Bhola district comprises of seven (7) upazilas. The site is located near Kutba Mouza of Kutba Union of Burhanuddin Upazilla.

## 5.2.1

### *Local Governance Set-up*

The District Magistrate (DM) is the Executive and Administrative Head of Bhola District. DMs in Bangladesh exercise vast executive and limited judicial power in their respective jurisdictions. The legislative representative from the district is the Member of Parliament who is elected every five years.

At the upazila level, Upazilla Chairman is the Executive head and is an elected representative. The Upazilla Chairman is assisted by the Upazilla Nirbahi Officer (UNO) and elected representatives from the constituent Union Parishads (Councils), together forming the Upazila Parishad (Council).

*Table 5.2* provides administrative distribution of Bhola District.

**Table 5.2** *Number of municipality, unions, mauza, mahalla and village in Bhola District*

Upazila	Municipality	Ward	Mahalla	Unions	Mauza	Village
Bhola Sadar	1	9	19	13	92	108
<b>Burhanuddin</b>	<b>1</b>	<b>9</b>	<b>13</b>	<b>9</b>	<b>57</b>	<b>46</b>
Char Fasson	1	9	9	19	68	77
Daulatkhan	1	9	9	9	25	25
Lalmohan	1	9	14	9	53	78
Manpura	0	0	0	4	18	30
Tazmuddin	0	0	0	5	36	75
<b>Total</b>	<b>5</b>	<b>45</b>	<b>64</b>	<b>68</b>	<b>349</b>	<b>439</b>

Source: Population and Housing Census 2011: Community Report- Bhola

### **Box 5.1**

#### *Definition of lower geographic, administrative or revenue units*

**Union:** Smallest administrative rural geographic unit comprising of mauzas and villages and having union parishad institution.

**Mauza :** Mauza is the lowest administrative unit having a separate jurisdiction list number (J.L. Number) in revenue records. Every mauza has its well-demarcated cadastral map. Mauza should be distinguished from local village since a mauza may consist of one or more villages.

**Village:** Lowest rural geographic unit either equivalent to a mauza or part of a mauza.

**Ward:** Smallest administrative urban geographic unit comprising of mahallas and having ward council institution.

**Mahalla:** Lowest urban geographic unit having identifiable boundaries.

**Paurashava/Municipality Area:** It includes paurashavas incorporated and administered by local government under Paurashava Ordinance, 1977.

Source: Population and Housing Census 2011: Community Report- Bhola

Dedicated government departments for Land, Agriculture, Fisheries, Health, Education, Animal Husbandry, Women and Child, Disaster Management etc. are present at the Upazilla level.

## 5.2.2

### *Key Demographic Features*

Bhola District is one of the six (6) districts of Barisal Division having a total population of 17, 76,795 which is 21.3% of total population of Barisal Division (83, 25, 666) as per Census 2011. The table below provides a brief comparative overview of key demographic features of Bhola District.



**Table 5.3 Comparative Demographic Overview of Bhola District (2011 Census)**

Key Indicators	Bangladesh	Barisal Division	Bhola District
Total Population	14,40,43,697	83,25,666	17,76,765
Total Households	3,21,73,630	18,62,841	3,72,723
Average Household Size	4.44	4.45	4.76
Sex Ratio	100	97	99
Area (sq.km.)	1,47,560.06	13225.20	3403.48
Population Density (sq.km)	976	630	522
Urbanisation (%)	23.30	16.36	13.69
Literacy Rate	51.8	56.8	43.2
Female Literacy Rate	49.4	55.9	42.9

Source: Population and Housing Census 2011: Community Report- Bhola

**Literacy:** It denotes ability to write a letter in any language. Literacy status assessment is made for population 7 years and over

**Sex Ratio:** number of males per 100 females

**Table 5.4 Comparative Demographic Overview of Bhola District (2001-2011)**

Key Indicators	Bhola 2001	Bhola 2011
Total Population	17,03,117	17,76,765
Total Households	3,28,670	3,72,723
Average Household Size	5.17	4.76
Sex Ratio	108	99
Area (sq.km)	3737.21	3403.48
Population Density (sq.km)	456	522
Urbanisation (%)	13.76	13.69
Literacy Rate (%)	36.9	43.2
Female Literacy Rate	34.1	42.9

Source: Population and Housing Census 2011: Community Report- Bhola

Bhola District has witnessed a decadal growth rate (2001-2011) of 4.14%. Due to the reduction in total area of the district (due to re-demarcation of district boundaries), there is a decline in population density (from 522 persons per sq.km.). There is improvement in Human Development indicators of sex ratio and literacy rate. There is low urbanisation in the district and most of working the population is engaged in agriculture and fisheries sector.

### 5.2.3 Industrial Profile

The study area is largely a rural based economy but with the discovery of natural gas in Shahbazpur Gas Field, the 225 MW BPDB power plant came into existence in 2008-09. This was the first large scale industrial project in the district of Bhola. The upcoming project will be located adjacent to the existing BPDB Power Plant. There is one more 35 MW power plant located near Bhola City. The numbers of different industries in Burhanuddin Upazila are provided below:

**Table 5.5 Number and types of Industries in Burhanudin Upazila**

Husking Craft Mills	Wooden Furniture	Saw Mills	Rice Mills	Flour Mills	Tailoring Shops
15	117	31	22	4	110

Source: Bhola District Statistics, 2011

**Figure 5.4** *Saw mill and Furniture Shop in Burhanuddin Town*



Source: ERM Socio-economic Survey January 2017

### 5.3 SOCIAL CAPITAL

#### 5.3.1 Local Demography

Bhola District has seven upazilas and the project is located in Burhanuddin Upazila. The total population of Burhanuddin Upazila is 2,33,860 which is 13.16% of total population of Bhola District. *Table 5.6* provides a brief comparative overview of key demographic features of all upazilas of Bhola District:

**Table 5.6** *Key Demographic Features of Upazilas in Bhola District -2011*

Upazila	Area (sq.km.)	Households	Population	Sex Ratio	Average HH Size	Density	Literacy Rate
Bhola Sadar	413.16	88068	430520	99	4.85	1042	45.2
<b>Burhanuddin</b>	<b>284.66</b>	<b>48534</b>	<b>233860</b>	<b>97</b>	<b>4.81</b>	<b>822</b>	<b>47.9</b>
Char Fasson	1106.31	94649	456437	100	4.82	413	43.5
Daulatkhan	316.99	34670	168537	98	4.86	532	41.6
Lalmohan	396.24	60988	283889	96	4.65	716	40.0
Manpura	373.18	17080	76582	102	4.48	205	32.1
Tazmuddin	512.91	28734	126940	105	4.42	247	42.9
<b>Total</b>	<b>3403.45</b>	<b>372723</b>	<b>1776765</b>	<b>99</b>	<b>4.76</b>	<b>522</b>	<b>43.2</b>

Source: Population and Housing Census 2011: Community Report- Bhola

The study area covers sections of the seven unions of Burhanuddin Upazilla. These are – Kutba, Kachia, Pakshia, Gangapur, Sachra, Deula and, Tabgi. In addition, the Burhanuddin Paurashava (Municipality) also falls within the study area. The total population of the study area is estimated to be lower than 1,82,218 (as Census 2011 data in the table below also includes data from

villages that may be outside the 5 km radius). The demographic details of these seven unions and Burhanuddin Paurashava are provided in *Table 5.7*.

**Table 5.7 Demographic Features of Study Area (Unions)**

Union	Household	Population	Average HH Size	Sex Ratio	Literacy
Kachia	6715	33722	5.02	99	48.2
Kutba	4752	22246	4.68	96	58.6
Pakshia	5088	23681	4.65	97	43.9
Deula	4252	21501	5.05	89	34.3
Gangapur	3606	16724	4.63	97	45.0
Sachra	3848	19431	5.04	97	36.1
Tabgi	6597	31713	4.80	97	50.6
Burahuiddin Paurashava	2649	13110	4.94	106	69.0
<b>Total</b>	<b>37507</b>	<b>182128</b>	<b>4.85</b>	<b>97</b>	<b>48.2</b>

Source: Population and Housing Census 2011: Community Report- Bhola

### 5.3.2 Age Distribution, Sex Ratio and Literacy

The sample households are predominantly comprised of people in the working age between 19 and 60 (58%). There are more females than males in the age group of less than 7 years of age.

**Table 5.8 Age Distribution: Gender Wise**

Gender	Less than 7 years	7 to 18 years	19-35 years	36 to 60 years	Above 60 years	Total
Male	31	141	182	111	27	492
Female	40	123	127	100	13	403
<b>Total</b>	<b>71</b>	<b>264</b>	<b>309</b>	<b>211</b>	<b>40</b>	<b>895*</b>

Source: Socio-Economic Household Survey by ERM 2017

\*age of 42 individuals was not reported

The sex ratio of the sample households was recorded as 112. This is higher than the overall sex ratio of unions in the study area.

The literacy rate in the sample households was recorded at 74% which is higher than the overall literacy rate of all unions in study area (48.2%). The female literacy rate was recorded as slightly lower than male literacy rate among the surveyed households i.e. 72% and 76%, respectively.

### 5.3.3 Community dynamics

More than 90 % of households surveyed practice Islam with the remaining belonging to Hindu religion. Most of the Hindus were reported to be living in villages of Dakshin Chota Monika, Dakhin Kutba and Uttar Kutba.

Community relationships are subject to power dynamics in the villages and are governed either by affiliation to a political party/ lineage, position of authority in the village administration or by the economic status of the family. Religion, caste and gender also play an important role in social interactions and power dynamics at the village level.

Several of these relationships are tied to the history of feudalism and socio-political influence of groups/families that have traditionally enjoyed economic, social and political dominance in the area. It was reported that Hindu population in the study area has reduced since 1971 with many Hindu families (some of them of big landlords and locally powerful people) out-migrated to India.

Social customs including marriages, community feasts, festivals etc. strengthen these dynamics and relationships and reflect the legacy of past interactions. These also characterise the linkages and affiliation with nearby villages, towns, markets etc.

Hence, men from high income families and landlords are reported to exert maximum influence in decision making in the villages of the study area. In addition, people holding influential positions like religious figures and priests, Union ward members, big traders or businessmen and people linkages with political parties, are also noted to wield their influence in community matters.

#### 5.3.4 *Prevailing Gender Dynamics*

Gender issues in the study area stem mostly from the question of equity, participation and role in the decision making process. Societies rooted in traditional norms of social behaviour include marriages (especially of girls) at an early age, and further, unequal treatment in decision making at the household level, lesser economic and social freedoms and opportunities for women. Most of the women are not involved in any economic activity outside of destock and household chores. There is a taboo associated with women using the plough among Hindu women and it was observed that none of the women in the project area are engaged in commercial fishing, in keeping with stated norms and gender roles.

Discussions with women stakeholders in the study area revealed that the living conditions and the environment at the village level has improved over the last decades, owing to advancements in provision of social infrastructure and increased mobility for women to access other villages and nearby markets. The average age of marriage has slowly but gradually risen. At the household level, almost all domestic activities have a role of women-harvesting, crop drying, child care, cooking etc. but still women hold a secondary position to that of men in decision making.

#### 5.3.5 *Human Rights*

According to the Section 2(f) of the National Human Rights Commission Act, 2009 of Bangladesh, "Human Rights" means Right to Life, Right to Liberty, Right to Equality and Right to Dignity of a person guaranteed by the constitution of the People's Republic of Bangladesh and such other human rights documents and ratified by the People's Republic of Bangladesh and enforceable by the existing laws of Bangladesh.

As per the (Annual Report 2011, National Human Rights Commission, Bangladesh 2011), the main complaints and cases that have been classified as human rights violation includes abductions, rapes, murders, custodial deaths, torture, human trafficking, domestic violence, enforced disappearance from homestead amongst others.

## 5.4 NATURAL CAPITAL

### 5.4.1 Land Tenure and Ownership Patterns

#### Land Tenure

The land tenure system in Bangladesh has evolved from the colonial *Zamindari* System and subsequent *Ryotwari* System (See Glossary). The forms and means of revenue thus have remnants of the erstwhile systems. The *Zamindari* System was abolished in 1950 through East Bengal State Acquisition and Tenancy Act 1950. M.A. Jabbar (1978) <sup>(1)</sup> opines that,

*“The main objectives of the Act (East Bengal State Acquisition and Tenancy Act, 1950) were to abolish all rent receiving interests between the government and the actual cultivator; to give permanent, heritable and transferable rights to rayots (later called Maliks); and fix the ceiling on land ownership at 33.33 acres per family. The Act was later subjected to various amendments. As a result, new tenure relationships emerged in Bangladesh agriculture and relative importance of these relationships has undergone changes over time.”*

Presently, the land tenure system in Bangladesh can be classified in three categories:

- (a) **Owner-operators** – those cultivating own land;
- (b) **Owner-cum-tenants**-those owning some land and renting additional land from others; and,
- (c) **Tenants**-those renting all the land cultivated.

Bhola District too, presents a similar picture and as per the Agriculture Census 2008, there are following number of farm-holdings across the categories mentioned above:

**Table 5.9** Number of farm-holdings as per Land Tenure Category-Bhola District

Upazila	Owner Holding	Owner cum tenant Holding	Tenant Holding	Total
Bhola Sadar	54691	23796	6949	55253
Burhanuddin	32882	12028	3071	29466

(1)M.A. Jabbar: Conceptual Issues Related to Classification of Land Tenure Systems in Bangladesh: *Bangladesh Journal of Agricultural Economics*, 1(1), 1978, pg 17-29. Sourced from-

<http://ageconsearch.umn.edu/bitstream/208745/2/1978-Land%20tenure%20system%20classification-BJAE.pdf>

. Accessed: 29 January 2017 at 16:34 hrs

Upazila	Owner Holding	Owner cum tenant Holding	Tenant Holding	Total
Char Fasson	50330	26704	5774	58705
Daulatkhan	23098	6406	2648	17221
Lalmohan	36337	14671	6495	36758
Manpura	11027	2720	1455	8306
Tazmuddin	17855	5622	2956	16722
<b>Total</b>	<b>226220</b>	<b>91947</b>	<b>29348</b>	<b>222431</b>

Source: Agriculture Census 2008 quoted in District Statistics 2011-Bhola

### *Bargadari System*

The land tenure system in the study area (and in other parts of Bangladesh) has a system of Bargadari or sharecropping. The Land Reforms initiated in 1950 targeted at abolishing Zamindari System, focusing on consolidation of land holdings and increased revenue for the state. But the Land Reforms Ordinance, 1984 introduced safeguards for tenants and prohibited the eviction of agricultural tenants from their homestead land. But the most important provision relates to the rights of bargadars or sharecroppers. The sharecroppers who cultivate the land of another person used to get only the half of the produce and another half used to go to the landowner, in spite of land owner not sharing the input cost (irrigation, seeds, fertilisers etc.). The new law provided that a 'barga' contract shall be executed between the landowner and the bargadar which will be valid for 5 years. The produce will be divided into 3 shares. One-third will go to landowner, one-third to the bargadar and the remaining one-third to the party, which provides seeds, fertiliser and irrigation. <sup>(1)</sup>

In the study area, Bargadari system was reported to be in prevalence, especially in the villages of Dakshin Kutba, Dakshin Choto Monika and Char Ghazipur. These villages are within 1 km of the project site. Based on the consultations undertaken by ERM with local bargadars, it was reported that bargadars give one-fourth of their seasonal rice produce to the owner of land. The bargadars have a contract valid for five years and the expenditure in irrigation, seeds and fertilisers is borne by the bargadar.

Consultations with land owners and other farmers in the study area revealed that most of the big landlords in and around the project location belonged to Hindu community. Post 1971-72, an outmigration trend was reported among Hindus towards India. Hence, most of the Hindu landlords sold their lands to local community or such land was redistributed to landless or marginal farmers by the government. In the villages of Dakshin Kutba, Dakshin Choto Monika, Char Ghazipur etc. this trend was reported to be prevalent in the present day context too.

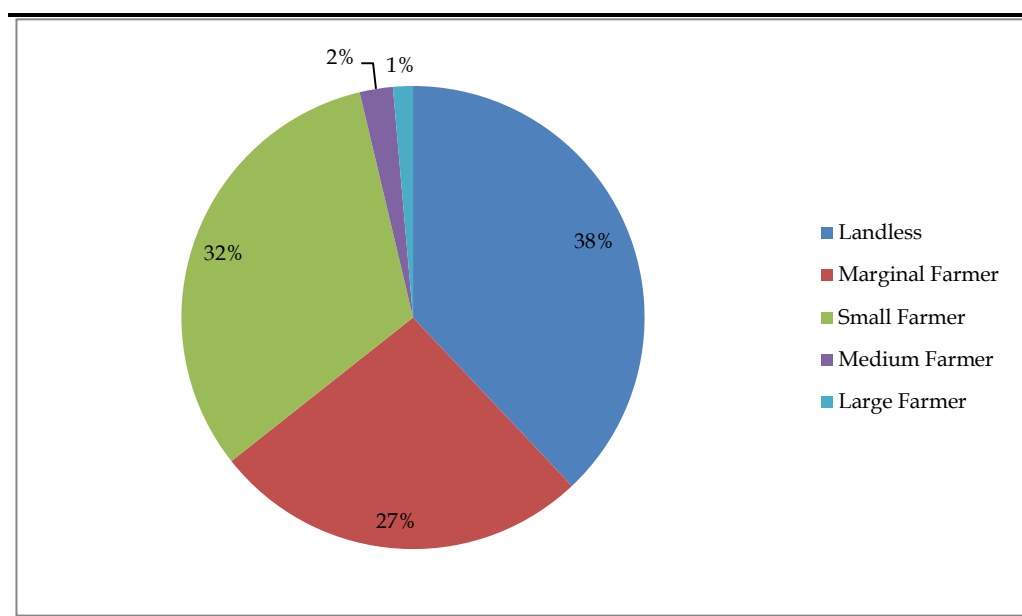
(1) [http://en.banglapedia.org/index.php?title=Land\\_Tenure](http://en.banglapedia.org/index.php?title=Land_Tenure) Accessed 29 January 2017 at 16:12 hrs



## Land Ownership Pattern

Land ownership pattern among the respondents of the socio-economic survey indicate that approximately 40% of the respondents fall in the landless category owning less than 5 decimal <sup>(1)</sup> of land. The pie chart below depicts the land ownership pattern across the surveyed villages.

**Figure 5.5** Land Ownership Pattern in Surveyed Villages



Source: Socio-Economic Household Survey ERM 2017

**Table 5.10** Land Ownership Pattern across surveyed villages

Village	No. of Households and Land Ownership Pattern (in decimal)								
	0	0-5	5-25	25-50	50-100	100-200	200-250	250-750	More than 750
Bara Kachia Ward 1	2	5	2	2	5	4	2	0	0
Bara Kachia Ward 2	3	3	3	1	2	4	0	3	1
Chagla	7	2	5	0	5	1	1	0	0
Char Gangapur	4	5	3	2	6	1	2	2	0
Char Ghazipur	4	3	2	2	7	2	1	0	0
Chota Deula	1	5	3	3	2	5	1	0	1
Dakshin Choto Monika	5	3	5	2	3	1	0	0	0
Dakshin Kutba	8	7	2	0	7	1	0	0	0
Fullkachia	1	4	1	10	3	1	0	0	0
Madhya Jaya	8	2	3	4	1	1	0	0	1
<b>Total</b>	<b>43</b>	<b>39</b>	<b>29</b>	<b>26</b>	<b>41</b>	<b>21</b>	<b>7</b>	<b>5</b>	<b>3</b>

Source: Socio-Economic Household Survey ERM 2017

Key (Source: Discussion with Agriculture Department, Burhanuddin Upazila)
<b>Landless</b> - 0 to 0.02 hectares (0 to 5 decimal)
<b>Marginal Farmer</b> - 0.02 ha to 0.2 ha (5 decimal to 50 decimal)
<b>Small Farmer</b> - 0.2 ha to 1 ha (50 decimal to 250 decimal)
<b>Medium Farmer</b> - 1ha to 3 ha (250 decimal to 750 decimal)
<b>Large Farmer</b> - more than 3 ha (more than 750 decimal)

(1) 1 hectare= 2.47 acres; 1 acre= 4046.86 square metres; 1 acre =25 katha; 1 katha=4 decimal

<https://www.google.co.in/search?q=acre+to+square+meters&oq=acre+t&aqs=chrome.2.69i57j0l5.4377j0j4&sourceid=chrome&ie=UTF-8>

More than 50 % of landless households do not own any land as per the results of the survey. One-fourth (27%) can be categorised as marginal farmers owning less than 50 decimal of land. Only three (3) respondents reported owning more than 3 hectares or 750 decimal of land (large farmers).

#### 5.4.2 *Land-based Livelihoods*

##### *Agriculture*

The district of Bhola is largely a natural-resource based economy with agriculture, fishing, and plantation agriculture being the main livelihoods. Rice, wheat, pulses, and vegetables are the main crops. Presence of deltaic alluvial plains formed by the rivers Tetulia, Meghna and other distributaries and channels coupled with high rainfall during monsoons creates a suitable condition of agriculture and intensive fishing. Agriculture is the main source of livelihood to the majority of working population in the study area. The table below outlines the area under cultivation of three unions located within 3 km of the project location:

**Table 5.11** *Area under Cultivation in Study Area*

Features	Sachra	Kutba	Kachia	Total
Total Number Farmers	7225	5497	6400	19122
Net Cropped Area (H)	2000	1768	2720	6488
Single Cropped Land (Ha)	70	40	112	222
Double Cropped Land (Ha)	1230	902	1526	3658
Tripled Cropped Land (Ha)	600	823	1082	2505
Rice Aman 1	150	305	160	615
Rice Aman 2	1855	1640	2470	5965
Boro	1285	1090	1680	4055
Betel Nut (Ha)	63	85	183	331
Coconut (Ha)	34	30	77	141
Betel Leaf (Ha)	5	22	22	49

*Source:* Agriculture Department, Burhanuddin Upazila

Rice is the main crop of the study area. Suitable climate and water availability provide for two-season paddy cultivation in the study area with some places cultivating three crops of paddy (which are closer to rivers, channels or canals). There are three main cropping patterns of rice as found in the study area:

**Table 5.12** *Rice Cropping Pattern in the Study Area*

Aman	Aus	Boro
------	-----	------

Aman	Aus	Boro
Aman rice is sowed in the months of March-April through broadcast method or in the month of May-June with the onset of monsoon. The higher yielding method involves transplanted during the summer monsoon. The crop matures during the monsoon season and is harvested in the months of November or December. The highest yield and productivity is in the Aman crop although the crop duration stretches to six to nine months.	The second harvest is aus, involving traditional strains but more often including high-yielding, dwarf varieties. Rice for the aus harvest is sown in March or April, benefits from April and May rains, matures during in the summer rain, and is harvested during the summer.	With the increasing use of irrigation, another rice-growing season extending during the dry season from October to March is found in study area. The production of this boro rice, including high-yield varieties is dependent on good irrigation facilities and is prevalent in the study area.
The main HYV crops of Aman rice are: Binadhan 7, 34 and Biridhan 51-52, 49, 44 and 54.	The main HYV crops of aus season are Biridhan 48 and 28.	The main HYV crops of Boro rice are Biridhan 47, 50, 28 and Binadhan 8 and 10.

Source: Consultations with farmers in study area and Agriculture Department, Burhanuddin

The household survey revealed that, of the 169 households who own land, 115 cultivate only one crop during monsoon. In winters, 94 households out of 169 reported that they cultivate two crops. Thus, we can see that Aman is the most popular crop. Farmers diversify their cropping pattern in winters or boro by growing other crops like wheat or vegetables or cash crops like mustard and betel leaves.

Figure 5.6 Agriculture in Study Area



Source: Socio-Economic Household Survey ERM 2017

Land parcels tend to be small and agricultural methods traditional. Increasing population, large family sizes, inheritance and mutation of land parcels have led to fragmentation and reduction of parcels sizes in the study area. Also people coming into Bhola for economic opportunities and leasing land for cultivation has headed towards further fragmentation of land holdings.

Large-scale, commercial farming is absent in the area, mainly due to the small size of the land holdings. Vegetables, pulses and oilseeds are grown in high numbers as mixed cropping supplementing paddy crops. These are mostly grown in kitchen gardens or small land parcels. Other crops include wheat during winters; pulses such as moong, masur and grams; vegetables like tomatoes, chillies, gourds, mustard, brinjals etc.

#### *Cash Crops and Plantations*

The study area is characterised by betel nut and Rendhi tree plantations which are traded both domestically and internationally. Other cash crops include betel leaves, coconut and bananas.

Other cash crops such as coconut, banana, vegetables and others are grown in orchards or kitchen gardens closer to homestead land of villagers. The Rendhi tree plantations are mostly found in the lower sections of Burhanuddin Upazila and Char Fason. Burhanuddin town has various saw mills where rendhi trees are cut into logs, planks and supplied to furniture and carpenter shops in Bhola and Burhanuddin.

#### **Box 5.2** *Betel Nut and Betel Leaves farming (Paan Boroz)*



Betel leaves are grown in an enclosed shed (locally known as *paan boroz*) made of dry leaves, bamboo and jute stems with creepers in the middle as cultivation needs to be undertaken in shade. This is mostly grown in winters between the months of January and March-April. Paan Boroz are located near household structures and are typically grown on 1 or 2 decimal of land with 5 to 6 lines of paan plants per decimal.

Pan boroz are often surrounded by betel nut trees or *supari* trees. There are generally 1200 supari trees per acre. Typically, one supari tree lasts for ~50 years giving annual income of BDT 500-100 per year



Betel Nut or *Supari* Trees

Source: Socio-Economic Household Survey ERM 2017

**Figure 5.7** *Rendhi Timber Trade*



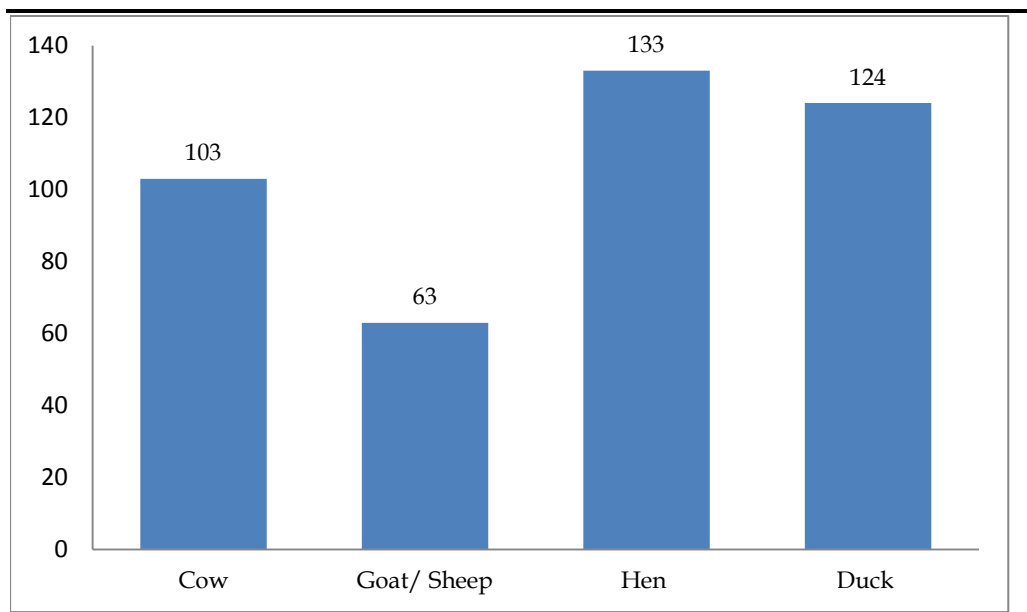
Source: Socio-Economic Household Survey ERM 2017

*Livestock*

Rearing livestock plays a very important role in the rural economy and is another source of household income. The cattle population is considered an added asset for a household and may be sold for ready cash in times of need. A typical household has, cows, goats, and poultry which are used both for generating income and to a lesser extent for household consumption.

There is considerable incidence of livestock rearing in the project area too, with almost 55 percent of households rearing livestock as per sample household survey. Bullocks, cows, goat, sheep, hens and ducks are the animals reared. The cattle population is fed through a combination of grazing and stall-feeding. Farmers depend on crop waste from agricultural fields and nearby pastures and grazing areas.

**Figure 5.8** *Households owning different cattle*



Source: Socio-Economic Household Survey ERM 2017

There has been a gradual reduction in grazing land for cattle due to increasing agricultural practices and conversion of land for agricultural use. There are few grazing areas remaining which are located close to river banks, river

floodplains and alongside roads and canals. It was reported to be people have adapted to the reducing grazing land by adopting stall-feeding mechanisms. In addition, people have started keeping more hens and ducks in comparison to cattle for ease of feeding and readily available market for poultry products.

### 5.4.3 *Fishing Livelihoods*

#### *Fishing Areas*

Bhola is the largest riverine delta island in Bangladesh flanked by Tetulia River in west and Meghna River in the east. Fishing thus, forms an essential component of people's livelihood in the district. It should be noted that only a small section towards north-east direction in the study area is located closer to Tetulia River. The project site is adjacent to the Dehular Khal which is an off-shoot distributary of Tetulia.

Consultations with fishermen near Tetulia River in Madhya Jaya indicated that fishing is prevalent in settlements close to the river. The main riverine fish species reported was ilish or hilsa. Large scale commercial fishing was reported to be absent in the study area with a prohibition of commercial trawlers in the upper reaches of delta rivers in place although there are some commercial trawlers who are licensed to go to the lower reaches of Meghna and Tetulia River closer to the Bay of Bengal.

It was reported that fishing in the region has overall declined in past few years due to overfishing through through trawlers in Tetulia River

#### *Fish Catch*

The average daily catch varies from season to season. Consultations with fishermen revealed that in the peak season of May to September, the average catch per fishing trip reportedly varies between 10-20 kg per fishing trip during the peak season and 10-12 kg per fishing trip in the winter (lean season). As reported, the frequency of fishing is mostly daily. As reported by villagers the major fish species caught in the study *Ilish, Rui, Bowal, Aar, Bele*.

#### *Fishing Boats*

The normally used fishing boats are of three types:



Figure 5.9 Types of Fishing Boats



Source: Consultations with fishermen and Fisheries Department, Burhanuddin Upazila: ERM January 2017

### Fishing Nets

There are different types of fishing nets used in the study area and beyond in the rivers in Tetulia and Meghna and to some extent in Dehular Khal. Some of the nets have been deemed illegal by the government in the backdrop of harm caused by them to aquatic ecology and sustainability of aquatic species. Different nets are used for different sizes of fishes. The table below explains the different types of fishing nets used in the study area:

Table 5.13 Types of Fishing Nets used in the Study Area

Fish Net (English)	Local Name	Description	Function	Types of fishes caught	Status	Seasonality
Gill Net	Chewa Jal	Mesh Size: 1.27 cm, Man power needed: 3, Making cost: Tk. 25000, Tk./Operation: 300	Fixed	Chewa	Legal	Jan-May
Seine Net	Kachki Jal	Mesh Size: 1 cm, Man power needed: 4, Making cost: Tk. 20000, Tk./Operation: 400	Enclosed (Drift)	Kachki	Legal	Dec-May
Gill Net	Current Jal	Mesh Size: 4-10 cm, Man power needed: 3-4, Making cost: Tk. 14000, Tk./Operation: 300	Drift	Ilish, Poa, Tengra, Ramsos, Taposi, Faissa	Illegal	Whole year

Fish Net (English)	Local Name	Description	Function	Types of fishes caught	Status	Seasonality
Gill Net	Churra Jal	Mesh Size: 2 cm, Man power needed: 3-4, Making cost: Tk. 14000, Tk./Operation: 300	Drift	Churra, Ramsos, Taposi	Illegal	Dec-April
Gill Net	2 shuta Cod Jal	Mesh Size: 5-10 cm, Man power needed: 3-4, Making cost: Tk. 14000, Tk./Operation: 300	Drift	Ilish, Poa, Ayr, Ramsos	Legal	Dec-April
Gill Net	Coral Jal	Mesh Size: 8-15 cm, Man power needed: 3-4, Making cost: Tk. 15000, Tk./Operation: 400	Fixed	Coral/vetki	Legal	Dec-May
Pull Net	Moia Jal, Moshari Net	Mesh Size: 2 mm, Man power needed: 1, Making cost: Tk. 700, Tk./Operation: 0	Pulled	Shrimp PL, Chanda, Juvenile of different fish species	Illegal	Dec-May
Set Bag Net	Benti, Behundi & Moshari Net	Mesh Size: 1 mm, Man power needed: 2, Making cost: Tk. 3000, Tk./Operation: 0	Setting with Bamboo/Anchor	Shrimp PL, Jatka, Chanda, Juvenile of different fish species	Illegal	Whole Year
Set Bag Net	Benti, Behundi & Moshari Net	Mesh Size: 2 mm, Man power needed: 1, Making cost: Tk. 10000, Tk./Operation: 0	Setting with Bamboo/Anchor	Jatka, Small Coral, Chanda, Fingerlings of different fish species	Illegal	Whole Year
Seine Net	Char Ghera Jal	Mesh Size: 1 cm, Man power needed: 1, Making cost: Tk. 10000, Tk./Operation: 0	Fixed and encircled with Bamboo	Jatka, Small Coral, Chanda, all juveniles and fingerlings of different fish species	Illegal	Whole Year
Set Bag Net	Badha Jal	Mesh Size: 1 cm, Man power needed: 1, Making cost: Tk. 15000, Tk./Operation: 0	Fixed with bamboo/anchor and floats	Jatka, Small Coral, Chanda, fingerlings of different fish species	Illegal	Whole Year
Gill Net	Chandi Jal	Mesh Size: 5-10 cm, Man power needed: 12, Making cost: Tk. 70000, Tk./Operation: 500	Drift	Ilish, Coral, Poa	Legal	Jul-Jan

Source: Consultations with fishermen and Fisheries Department, Burhanuddin Upazila -ERM January 2017

### Fish Markets and Income

The main fish markets in the project area are located in Burhanuddin, Bhola, Guingar Hat, Bangla Bazar and small markets located in Kachia, Kutba, Chagla, Gangapur etc. In these markets, the most common fish i.e. *ilish* is sold at approximately BDT 300/kg. It was reported that per trip income of fishermen ranged from BDT 3000 in peak season to BDT 1500 in lean season. The fishing income is divided in five portions between boat owner and other fishermen with boat owner getting two portions (40%) and others getting the remaining 3 portions (60%).

## *Aquaculture or Pond Fishing*

There is prevalence of aquaculture or pond fishing in the study area. As per the data received from the Fisheries Department, Burhanuddin Upazila, there are a total of 18,570 registered fishermen in the upazila. The table below provides overall figures of pond fishing.

**Table 5.14** *Aquaculture in Burhanuddin*

<b>Feature</b>	<b>Figures</b>	<b>Area</b>
Total Number of Ponds	8670	Area: 3032.4 Acre
<i>Khas</i> (Govt.) Ponds	34	Area: 11.90 Acre
Yearly Fish Demand in Upazila	5,236.27 M. Ton	
Fish Produce	3,960.45 M. Ton	
Ave. Fish produce per decimal in Pond	12 kg	
Ave. Fish produce per decimal in River	3 kg	

*Source:* Fisheries Department, Burhanuddin Upazila (year 2016)

The main fish species farmed in aquaculture are *rohu*, *katla*, *mrigel*, *kali barsh*, *pangash*, *tilapiya* and different sizes of *prawns* and *shrimps*.

The overall fish production in Burhanuddin is lower than the demand and hence, fish is traded in from neighbouring upazilias of Char Fason, Lal Mohan, Daulat Khan and other districts of Barisal Division.

## 5.5 **ECONOMIC CAPITAL**

### 5.5.1 **Occupational Profile**

The economy of Bhola is predominantly agricultural. Out of total 347,515 land holdings of the zila, 64.01 % holdings are farms that produce varieties of crops namely local and High Yielding Variety (HYV) rice, wheat, vegetables, jute, spices, cash crops, pulses, and others. Various fruits like banana, mango, guava, jackfruit, black berries, coconut, papaya, palm, lichi, dates etc. are grown. Agriculture is the main livelihood source and economic activity in the study area too, with 60% of surveyed households reporting agriculture as their primary occupation. This includes cultivators of owned holdings, tenant holdings, cattle rearers and agricultural labour.

Most of the households are dependent upon agriculture. A typical family in the area grows one/ two crops of rice during the year and has one/two members who are engaged in other activities (farm and non-farm, fishing or in some local business unit like shops or other business enterprise). To supplement their income, some of the households own a number of livestock, usually cows, goats, and poultry products. Ownership of livestock cuts across landowners, sharecroppers and landless families and so do the levels of dependence of the family upon them for income and sustenance.

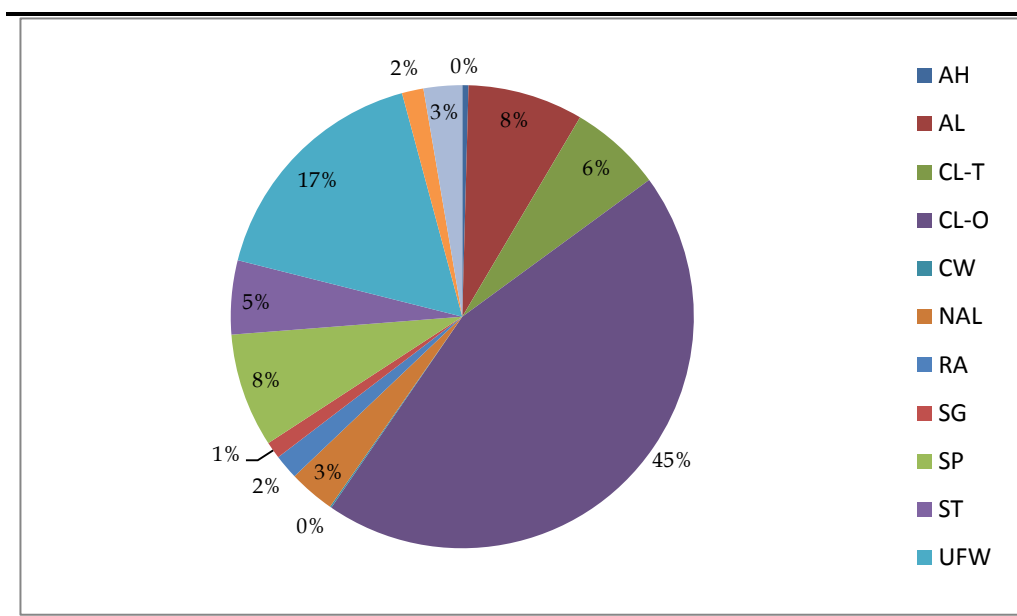
Fishing has been reported as an occupation and in the areas closer to Tetuliya River and to a lesser extent near Dehular Khal.

Livelihoods in the sample households can be divided into three sectors:

- **Farm-based:** includes agriculture, fishing, and livestock.
- **Non-farm based:** includes industrial work, manufacturing, sand mining, brick kilns etc.
- **Tertiary:** includes services and skill based work such as driving and rickshaw pulling, carpenters, mechanics, traders and shopkeepers, cooks, electricians etc.

The chart below provides a pictorial representation of the occupational profile of the surveyed households in the study area:

**Figure 5.10 Occupational Profile in the Study Area**



Source: Socio-Economic Household Survey ERM 2017

**Key**

AH	Animal Husbandry	SG	Service in Government Sector
AL	Agricultural Labourer	SP	Service in Private Sector
CL-T	Cultivator as Tenant	ST	Small Trader
CL-O	Cultivator as Owner	UFW	Unpaid Family Work
CW	Contractual Labourer	UM	Unemployed Seeking employment
NAL	Non-agricultural labourer	O	Others
RA	Rural Artisan		

**5.5.2 Informal Labour**

Local community members are engaged in wage labour activities. In the Household Survey, it was reported that 13.3% of local population has wage labour as its main occupation. Wage labour in the study area is generally of two types- Agricultural Labour and Non-agricultural Wage Labour.

**Agricultural Labour** refers to labour activities undertaken during sowing and harvesting season. The agriculture labour arrangement among the local

community members is based on daily wages and this range from BDT 200-300 depending on the workload.

**Non-agricultural Labour** refers to labour activities undertaken in non-agricultural activities like loading, construction, etc. The different forms of non-agricultural labour include manual unskilled work in brick kilns, fishing boats, saw mills etc.; skilled labour as masons, electricians, carpenters etc. The wage rates range between BDT 300-500 depending on workload and skill involved.

**Table 5.15** *Daily average rate in Bhola District (in BDT)*

Upazila	Agricultural Labour	Mason	Carpenter (construction)	Electrician (construction)	Porter/Manual Labour	Gardener
Bhola Sadar	300	400	350	400	300	300
<b>Burhanuddin</b>	300	400	350	450	300	300
Char Fasson	250	400	300	500	500	250
Daulatkhan	300	400	350	400	275	220
Lalmohan	290	400	500	500	400	0
Manpura	220	350	250	400	300	200
Tazmuddin	300	350	300	300	350	250
<b>District Avg</b>	<b>280</b>	<b>385</b>	<b>342</b>	<b>421</b>	<b>209</b>	<b>217</b>

Source: District Statistics 2011-Bhola

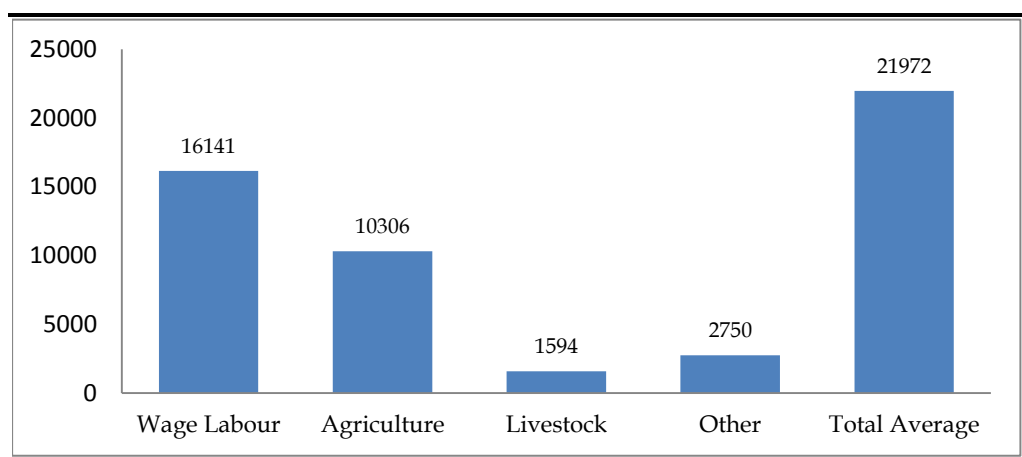
### 5.5.3 *Fixed Asset Ownership*

Consultations undertaken in the study area indicate that land is the most prized fixed asset in the area. Land is used for homestead, agriculture, plantation and ponds and hence, is the asset around which the socio-economic and cultural lives of villagers revolve. For fishermen, boats, nets and other fishing gear are essential. Land ownership pattern in the study area has been discussed in *Section 5.4.1*.

### 5.5.4 *Income*

Assessment of household income and expenditure patterns and an analysis of the trends across different villages showed consistency in terms of income levels, sustenance needs, and expenditure levels. The patterns and heads of expenditure and sources of income were found to be similar due to the similarity in the livelihood and occupation patterns, means and opportunities available in the study area. The average monthly income of the study area as per the household survey is BDT 21,972. The figure below provides the average income figures for various sources of income in the study area:

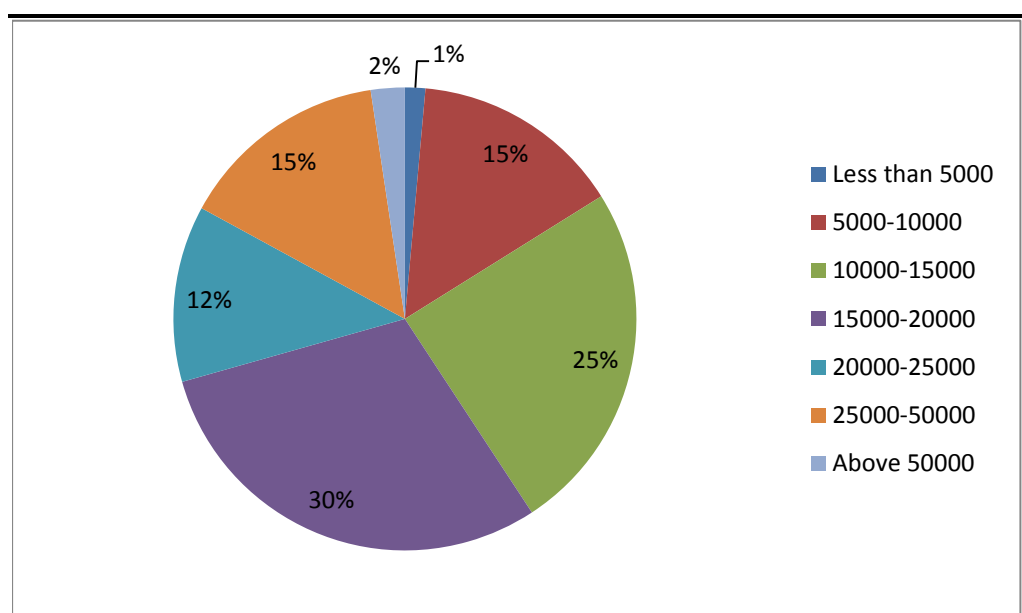
**Figure 5.11** *Average Monthly Income from various sources in Study Area*



Source: Socio-Economic Household Survey ERM 2017

30% of the households earn between BDT 15,000 and 20,000 per month while 16% earn less than BDT 10,000 per month. The figure below presents distribution of surveyed households across income ranges.

**Figure 5.12** *Households in different income groups (monthly income in BDT)*



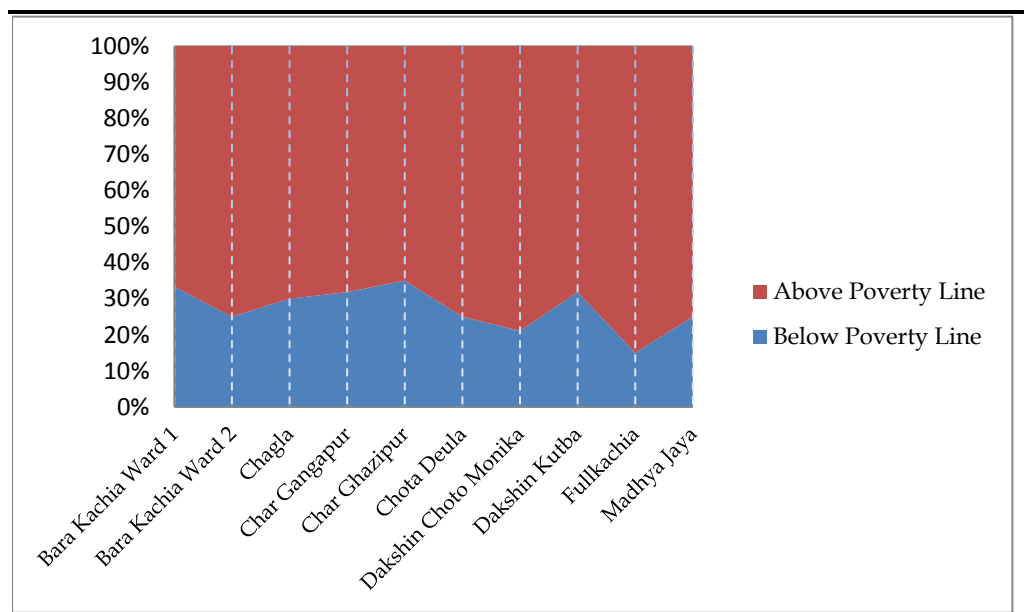
Source: Socio-Economic Household Survey ERM 2017

The average per-capita income as per the household survey was recorded at BDT 4860 per month or BDT 162 per person per day. As per the World Bank <sup>(1)</sup> poverty line (\$1.25 or BDT 100 per person per day), more than one-fourth (26%) of the households surveyed earn less than BDT 100 per person per day and hence fall below poverty line. The figure below provides the percentage of households living above and below poverty line in each of the 10 villages surveyed.

(1) <http://blogs.worldbank.org/developmenttalk/international-poverty-line-has-just-been-raised-190-day-global-poverty-basically-unchanged-how-even>



**Figure 5.13** Households living above and below poverty line

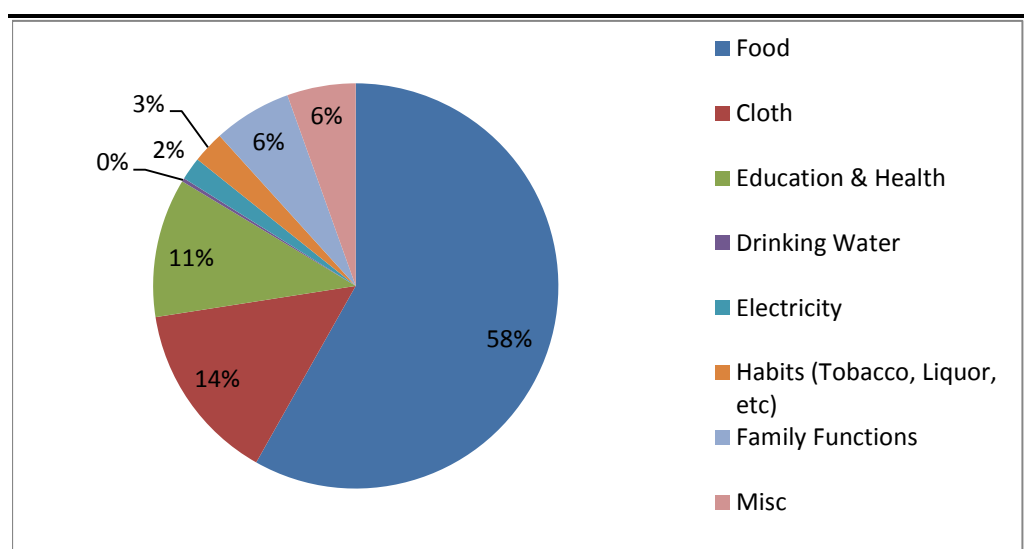


Source: Socio-Economic Household Survey ERM 2017

### 5.5.5 Expenditure Patterns

The key heads of expenditure ranges from expenditure incurred on housing, food, clothing, entertainment, travel, education and health care. Broad estimates of monthly expenditure were reported to be in the range from BDT 5000 per month to BDT 25,000 per month depending upon the size of the household, number of earning members, land and asset ownership etc. The figure below provides average percentage share of various items in monthly household expenditure.

**Figure 5.14** Expenditure Pattern



Source: Socio-Economic Household Survey ERM 2017

Maximum expenditure in households of the project area is incurred on food (58 percent) followed by clothing (14 percent); education and health (11 percent).

### 5.5.6 *Indebtedness and Credit*

As per the Household survey, 30% of the households are in some form debt. Of the households which are in debt, the average debt in BDT among them is reported to be approximately BDT 43926. The main sources of debts are banks and micro-finance institutions. *Section 5.7.1* discusses access to finance in the study area.

### 5.5.7 *Local Economic Markets*

The main market in the study area is Burhanuddin which is 3 km from site where people in the study area go to buy, sell and trade in agricultural products, furniture, household groceries and ration, construction material, vehicles etc. Other markets in the and around the study area are: Ghuinghar Hat, Bangla Bazaar, Bhola, Ghazipur etc. there are dedicated local markets (known as growth centers) and rural markets located in Pakshia, Mirzakal Hat, Maulabir Hat, Sachra, Moazzam Hat, Kachia Hat, Shanter Hat etc.

### *Box 5.3 Implications of BPDB Plant*

The BPDB Power Plant constructed in 2008-09 led to some short term economic implications in the local area in form of petty contracts, wage employment (during the construction phase), growth of small grocery shoops and food stalls etc.

The village of Kutba is closest to the project plant site of BPDB and a small market has appeared in the area outside the gate. This includes shops, food stalls, vegetable vendors, car/bike repair etc. Four shops have opened within Kutba village which were started after BPDB became operational.

During the construction phase, residents of villages of Kutba, Dakshin Kutba and Dakshin Choto Monika were engaged as unskilled labour. Some people also got contracts for supplying of raw materials for construction, groceries, food items. The construction was undertaken to a company from China and a labour camp was set up adjacent to the BPDB plant. Few local contractors were engaged for supply of daily items for the labour camp occupants.

## 5.6 *HUMAN CAPITAL*

### 5.6.1 *Civil Society Organisations*

Several civil society organisations (CSOs) or non-government organisations (NGOs) are functioning in the delta island of Bhola. They work in the sector of health care, education, micro-financing, thrift and credit, governance and advocacy on human rights. The following table summerises some of the active NGOs and their sectoral activities:

**Table 5.16** *Active NGOs and their Sectoral Activities*

Sl. No.	Name of the NGO	Sectoral Activities
1.	Coastal Association for Social Transformation (COAST)	Micro-credit, Local Governance

Sl. No.	Name of the NGO	Sectoral Activities
2.	Social Welfare Organisation	Water & Sanitation, Education (especially dealing with dropouts), Awareness against Child Marraiage
3.	My Right	Advocacy on Human Rights
4.	ASHA	Education, Health, Micro-finance
5.	BRAC	Micro-finance, Health, Education
6.	Jana Unnayan Sangsthan	Skill training for yoouths

### 5.6.2 *Skills and Formal Employment*

Skill levels are very low amongst the community in the study area. Consultations revealed that except for some basic works of masonry, carpentry or technical jobs of repairing, welding etc. skilled labor has to be sourced from nearby towns and urban centers. However, market places in Burhanddin, Bangla Bazar, Ghuinghar Hat, and Bhola have shops providing basic repair services. The absence of skills can be broadly attributed to two factors:

- Absence of skill-based employment opportunities in the near vicinity; and
- Lack of interest in the community regarding the utility of such trainings in successful generation of employment, viable income source.

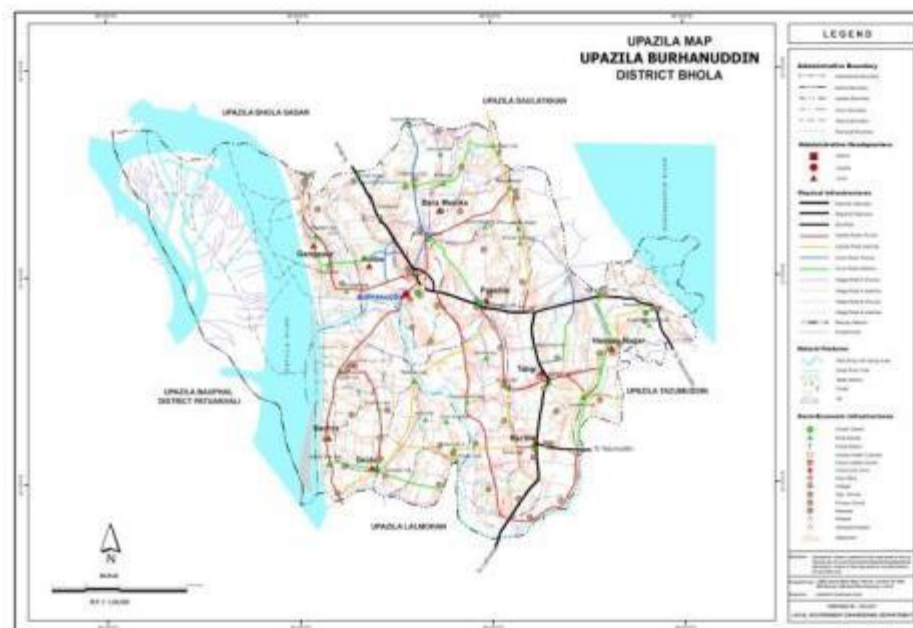
There a few NGOs working in the field of skill development such as COAST, Social Welfare Organization, ASHA, BRAC etc. There is a polytechnic institute located in Bhola as well.

### 5.6.3 *Community Health*

Currently there are very few risks associated with community health and safety borne out of industrial activities due to limited industrialization in the area. Nonetheless, villages close to BPDB plant reported to have witnessed increased dust emissions during construction phase, and increase noise levels although no major complaints or grievances were revealed.

Discussions with local community indicated that there are frequent outbreaks of diarrhoea owing to water quality and food habits. Other common diseases in the study area are: Pneumonia, Respiratory Tract Infections, Typhoid, Tuberculosis, Diabetes, Malaria etc. it was reported that people have started preferring institutional delivery at Burhanuddin hospital, however, there continue to be midwives in the villages in study area.

Figure 5.15 Infrastructure Profile of Burhanuddin Upazilla



\*Source: LGED Upazilla Office Burhanuddin

## 5.7.1

**Social Infrastructure***Health Service Delivery*

The project area suffers from poor health infrastructure and services and there is a substantial gap in physical infrastructure as well as paucity of health-care personnel. The health-care facilities in the study area are thinly spread and even the existing facilities suffer from inadequacy of equipment, accommodation, staff and medicines. Burhanuddin has a 50-bed hospital run by the Health Department which has delivery unit, pathology, emergency and casualty section etc. There are Family Health Clinics located in Tabgi, Kachia, Deula, Darun Hat, and Khurar Hat.

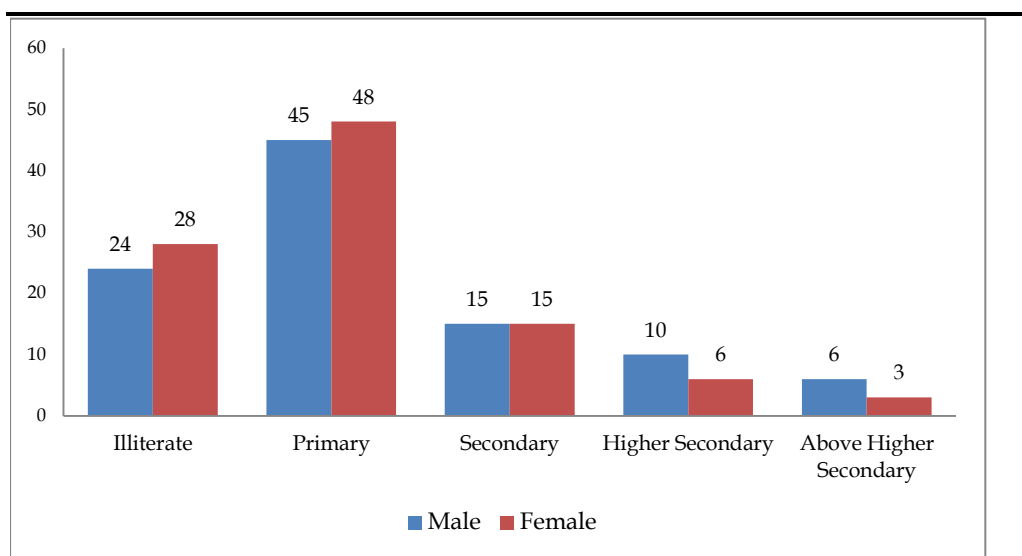
The need and willingness to access Health-care is determined by people's belief system and also their economic levels.

Poor maternal and child health indicators presumably result from early marriages and poverty; since children born to very young mothers are more likely to be premature, have low birth weights, and suffer from complications at the time of delivery; poor nutrition and hygiene, lack of trained and institutionalised support before, during and after delivery. Consultations with women indicated hardships faced by pregnant women with paucity of pre-natal and post-natal care although improvement in institutional delivery mechanisms was reported in some villages.

### Formal Education

There are 38 primary schools, 12 high schools and 6 madrasas in Burhanuddin Upazila. The study area too has adequate access to primary and high schools although it was reported that there are very few higher education institutions in the study area. The closest college is located at Bhola city (28 km away). An indicative chart on reported levels of formal education among men and women (above 7 years) in the study area are in the figure below.

Figure 5.16 Gender wise - level of formal education (in %)



Source: Socio-Economic Household Survey ERM January 2017

### Access to Water

Drinking water is extracted from deep tube wells Deep (800-900 feet depth) and consumed without treatment. The study area is also dotted with numerous ponds (*pukurs*) which are used for all water requirements for domestic consumption including washing, bathing, gardening etc.

Drinking water is extracted from deep tube wells Deep (800-900 feet depth) and consumed without treatment

### Access to Finance

According to the Central Bank of Bangladesh<sup>1</sup>, the financial system prevalent within the country is comprised of three broad fragmented sectors, i.e. formal, semi-formal, and informal sector. Access to various financial sectors in Bhola District and Burhanuddin Upzilla varies in urban and rural clusters. Based on discussion with the individual stakeholders such as MMS, BRAC, Department of Social Welfare, as well as the overall community within the AOI, it was

<sup>1</sup> Bangladesh Bank (<http://www.bb.org.bd/fnansys/index.php>)

reported that, the formal and the semi-formal sectors mostly catered to the urban populations within the paurasavas, wards and municipalities, etc. while the semi-formal and most of the informal sectors catered to the financial requirements of the rural population. Some of the key microfinance agencies and NGOs that represent the semi-formal agencies within the study area include Grameen Bank, Islamic Bank and BRAC, ASHA, COAST, Grameen Janunnati Sanstha amongst others.

**Box 5.4**      ***Overview of Grameen Bank, one of the largest microfinance institutions of Bangladesh***

The *Grameen Bank* is a Nobel Peace Prize winning microfinance organization and community development bank started in Bangladesh that makes small loans (known as microcredit or "grameen credit") to the impoverished without requiring collateral. The name *Grameen* is derived from the word "gram" which means "rural" or "village" in the Bengali language.

The system of this bank is based on the idea that the poor have skills that are under-utilized. A group-based credit approach is applied which utilizes the peer-pressure within the group to ensure the borrowers follow through and use caution in conducting their financial affairs with strict discipline, ensuring repayment eventually and allowing the borrowers to develop good credit standing. The bank also accepts deposits, provides other services, and runs several development-oriented businesses including fabric, telephone and energy companies. Another distinctive feature of the bank's credit program is that the overwhelming majority (98%) of its borrowers are women

Source: <http://www.grameen-info.org/>

In the household survey, only 26% of households were reported to have taken credit with almost 95% of them having taken loans from money lenders. This indicates that private money lending has come down due to the existence of micro-finance and other formal credit mechanisms.

**5.7.2**      ***Physical Infrastructure***

*Road and Transport Networks*

The LGED maintains rural roads. Generally, rural roads have a load bearing capacity of just 20-25 tonnes. The main road in the study area is the Bhola-Char Fason Road. Most of the roads connecting union centres with villages with villages are *pucka* while internal roads in villages are trails and dirt tracks or *kutchra*. Regular buses ply from Bhola and Burhanuddin to other places in the district and to major cities like Barisal, Khulna, and Dhaka etc. For daily travel within the study area, people use private rickshaws, shared taxis and vans and buses.

The study area, as in the rest of delta regions in Bangladesh has a strong waterways connectivity. Overnight ferries (or launch) regularly ply on the Bhola-Dhaka, Bhola- Barisal, Burhanuddin-Lalmohan routes. Bhola is the biggest launch terminal in Bhola District.



### *Sanitation and Waste Management*

All households during the household survey were found to have toilet facilities. A majority of the households (77%) of households reported to use pit latrines while others have flush toilets. Most of the toilets were located within homestead land outside of the main house.

There is no drainage system in the villages of study area, while in Burhanuddin drainage coverage is minimal. Sewage waste is generally decomposed in septic tanks or latrines pits or drained into ponds.

### *Electricity*

Two-thirds (65%) of the households reported to have electricity connections. 76% of households falling below poverty line did not electricity connection.

#### **5.7.3 *Overview of Development Needs***

Consultations with local community and government officials in the study area indicated that people expect improvement in conditions of main roads, paving of kutchra roads, better transport connectivity especially with small islands. They were also of the opinion that as the natural gas field is located in Bhola district; the residents of the district should get electricity and improvement in socio-economic conditions of the area through employment, better health services and education and skill development support.

#### **5.7.4 *Adaptation to Extreme Events***

Communities face health and safety risks due to natural calamities like cyclones, floods, heavy rainfall and cloud bursts and possibly outbreak of epidemic (due to poor public health infrastructure in the area). The main natural disaster threat in the study area is devastation cause by tropical cyclones. The last major cyclone in the study area was reported to have hit the district in 1970s. After that, while small cyclones have hit the area, the devastation levels have been thin. As the district is located very close to the Bay of Bengal, occasional storms and torrential rainfall during monsoon season are regular occurrences which cause harm to crops, livestock and structures.

Burhauddin Upazila has a Disaster Management Centre which has been made responsible to create early warning systems, communication flow and relief and rescue. Each primary school is being upgraded as a Cyclone shelter. The Disaster Management Cell specially focuses on tracing fishermen during any incoming storm and communicates through selected disaster management representatives in each fishing village.

Figure 5.17 Cyclone shelter in Shantipara Village, Kachia



\*Source: Socio-Economic Household Survey ERM January 2017

## 5.8 VULNERABILITY

The information available on the study area is summarized using this framework for assessing the overall vulnerability of communities living within it. The assessment is provided in the matrix below.

Table 5.17 Vulnerability Assessment

Capital	Specific Considerations	Assessment of Vulnerability	Specific Vulnerable Receptors
Physical Capital	Education Facilities	<ul style="list-style-type: none"> <li>Overall presence of higher education, health care, and transport services in project area of influence is poor.</li> <li>The housing quality in the study area is poor with most houses being <i>semi-pucka</i> or <i>Kutchha</i>. Very few houses were observed to be <i>pucka</i>.</li> <li>The services and infrastructures at village level are reported to be of reportedly of unsatisfactory level due to lack of proper implementation of government schemes and institutions in the area.</li> </ul>	Villages located further away from Burhauddin and Bhola towns are more vulnerable in terms of availability and access to physical capital.
	Health Care Facilities		
	Transport Facilities		
Social Capital	Fair Policing and Security	<ul style="list-style-type: none"> <li>Nearest Police Station is in Burhanuddin. The law and order in villages is more or less governed by customary laws exercised by community groups and religious laws.</li> <li>Traditional social structure of caste and religion based groups runs parallel to the formal administrative structure. This takes effect mostly at times of conflicts, marriages and village functions.</li> <li>The influence of formal administrative system in project area is strong although the people reported in avoiding legal or judicial process and recourses.</li> </ul>	The possibility of differential treatment towards religious minorities and women cannot be discounted.
	Strong Social Networks and connectedness		
	Freedom from inter and intra community Conflict		
	Rights/ ability to participate in decision making		
Human Capital	Knowledge and skills	<ul style="list-style-type: none"> <li>Literacy level of the population is</li> </ul>	The women have greater

Capital	Specific Considerations	Assessment of Vulnerability	Specific Vulnerable Receptors
	Access to and level of education Health and Nutrition Status	average. <ul style="list-style-type: none"> <li>Common diseases are related to digestive and respiratory systems.</li> </ul>	vulnerability due to low level of literacy and lesser employment opportunities.
Economic Capital	Diversity of livelihoods Productivity of Livelihood Access to Savings and support networks Adequate level of income generation Access to loans and credit	<ul style="list-style-type: none"> <li>Reliance on farming, fishing and livestock rearing</li> <li>Low levels of income relative to expenditure, which would get worse with inflation affecting affordability of essential commodities.</li> <li>Low ability to pay for key services, resources and infrastructure.</li> <li>Improving access to savings, loans, banking, and financial support systems.</li> </ul>	Marginal and Small Farmers with less amount of land.
Natural Capital	Water Agriculture Forestry	<ul style="list-style-type: none"> <li>Heavily dependent on farm land</li> <li>High reliance on monsoon rains and groundwater.</li> <li>Reliance on agriculture, livestock rearing and fishing.</li> </ul>	Women who have the responsibility of fetching water and keep livestock will be more vulnerable.

For the purpose of assessing vulnerability in the project area, the main criteria of economic vulnerability have been used. Households having a per capita per day income of less than BDT 100 have been considered as those falling below the poverty line. This figure has been taken out from World Bank International Poverty Line of \$1.25 <sup>(1)</sup>. It was reported that 55 households or 26% of the household survey respondents were falling Below Poverty Line. In addition, single women headed households, households with disabled members and old age households have been also considered vulnerable.

(1) <http://blogs.worldbank.org/developmenttalk/international-poverty-line-has-just-been-raised-190-day-global-poverty-basically-unchanged-how-even>

## 6.1

*INTRODUCTION*

This section assesses the manner in which the Project will interact with elements of the physical, ecological, social, cultural or human environment to produce impacts to resources/receptors. This has been organized as per the various stages of the project lifecycle to understand the risks and impacts associated with each of these individual stages.

The Project does not envisage any significant environmental/ social impact in the pre-construction phase, which primarily involves feasibility study and possession of land for development of the power plant, as majority of the land required for the project is already under possession of BPDB adjacent to its Bhola-I CCPP project. The project requires some additional land in order to accommodate dual fuel power plant, approach road to the land by acquisition/ purchase of private land, and the right of way for the gas pipeline. The socio-economic issues related to same are separately discussed under social impact section.

Hence, the environmental and social impacts due to the Project activities are considered in the distinct stages of the Project life cycle: (a) pre-construction and construction of the Plant (Construction Phase); and (b) operation and maintenance of the Plant (Operation Phase). Risk assessment and consequence analysis due to the project activities and operations is separately captured in Section 8 of this report.

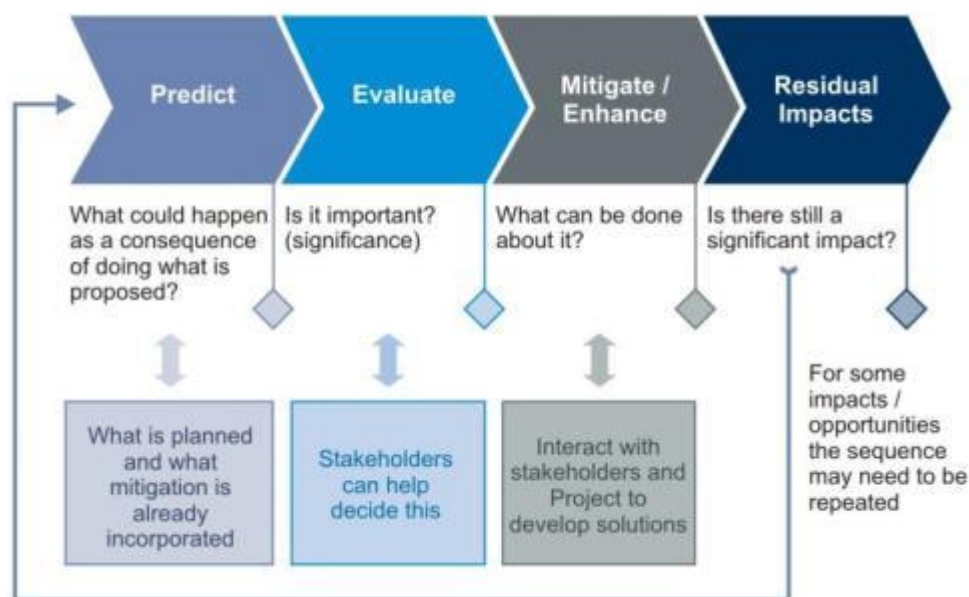
Environmental and social impacts during decommissioning of the Plant have not been considered in the impact assessment, as these will depend on the options available at the time of expiry of the power purchase agreement between NBBL and BPDB. The design life of the power plant is estimated to be 30 years, which is almost 8 years longer than the Power Purchase Agreement term.

If the Power Purchase Agreement, Land Lease Agreement, Gas Supply Agreement and the other relevant agreements are not extended or renewed and an alternative economical fuel is available, the power plant may be retrofitted to support alternative power generation. This option would be possible, provided that the required retrofits and new emission rates meet the applicable standards and guidelines. If retrofitting is not a feasible option, and the operational life of the Power Plant expires, the power plant will be decommissioned according to the requirements of the authorities at that time. NBBL will require to undertake an appropriate assessment of environmental and social risks and impacts with respect to the most feasible option.

Impact identification and assessment starts with scoping and continues through the remainder of the IA Process. The principal IA steps are summarized in Figure 6.1 and comprises of:

- **Impact prediction:** to determine what could potentially happen to resources/receptors as a consequence of the Project and its associated activities.
- **Impact evaluation:** to evaluate the significance of the predicted impacts by considering their magnitude and likelihood of occurrence, and the sensitivity, value and/or importance of the affected resource/receptor.
- **Mitigation and enhancement:** to identify appropriate and justified measures to mitigate negative impacts and enhance positive impacts.
- **Residual impact evaluation:** to evaluate the significance of impacts assuming effective implementation of mitigation and enhancement measures.

Figure 6.1 Impact Assessment Process



### 6.2.1

#### Prediction of Impacts

Prediction of impacts was carried out with an objective to determine what is likely to happen to the environment as a consequence of the Project and its associated activities. From the potentially significant interactions identified in Scoping, the impacts to the various resources/receptors were elaborated and evaluated. An activity – impact interaction matrix for construction and operation phases of the Project is presented in Table 6.1, which has been further used to assess the impact significance at activity levels on environmental, ecological and social resources.

Table 6.1 Activity-Impact Interaction Matrix for Construction and Operation Phases of the Project

Project Activity/ Hazards	Environmental Resources											Social Resources										
	Land Forms/ Profile	Soil/ Sediment Quality	Land Use	Air Quality	Climate Change	Drainage Pattern	Surface Water Quantity/Quality	Ground Water Quality	Ambient Noise Levels	Vibration	Occupational Health & Safety	Terrestrial Ecology	Aquatic Flora/ Fauna (Biodiversity)	Demographics (i.e. Displacement)	Economy & Livelihoods	Social & Cultural Structures	Land Use (Inc. Economic Displacement)	Infrastructure & Services	Cultural Resources	Community Health & Safety	Vulnerable Groups	Social/ Community Cohesion
<b>Construction Phase</b>																						
Site Clearing/ Levelling																						
Building of structures including temporary structures and laying of pipelines																						
Heavy equipment operations																						
Storage, handling and disposal of waste																						
Generation of sewage																						
Influx of construction workers																						
Transportation of power plant equipment over water																						
Transportation of personnel & material by road																						
Storage and handling of chemicals (unplanned release)																						
Maintenance of vehicles and equipment																						
Concreting works																						
<b>Operation Phase</b>																						
Air emissions from stacks of the plant																						
GHG emissions																						



Project Activity/ Hazards	Environmental Resources											Social Resources											
	Land Forms/ Profile	Soil/ Sediment Quality	Land Use	Air Quality	Climate Change	Drainage Pattern	Surface Water Quantity/Quality	Ground Water Quality	Ambient Noise Levels	Vibration	Occupational Health & Safety	Terrestrial Ecology	Aquatic Flora/ Fauna (Biodiversity)	Demographics (i.e. Displacement)	Economy & Livelihoods	Social & Cultural Structures	Land Use (Inc. Economic Displacement)	Infrastructure & Services	Cultural Resources	Community Health & Safety	Vulnerable Groups	Social/ Community Cohesion	
Noise generation due to operation of plant and auxiliaries																							
Water demand for plant operations																							
Wastewater discharge/ disposal																							
Wastes - domestic waste and other non-hazardous wastes handling, storage																							
Hazardous material and waste storages																							
Natural gas transportation by pipeline																							
HSD transportation by pipeline																							
Transportation of personnel, raw material/s and disposal of wastes																							
Employment																							
<b>Operation of Bhlola I &amp; II Projects (Cumulative)</b>																							
Water Demand for plant operations																							
Wastewater discharge/ disposal																							
Air emissions from stacks of the plants																							
GHG emissions																							
Noise generation due to operation of plants and auxiliaries																							

☐ = Represents "no" interactions is reasonably expected

◐ = Represents interactions reasonably possible but none of the outcomes will lead to significant impact

◑ = Represents interactions reasonably possible where any of the outcomes may lead to potential significant impact

For ecological impacts, interactions that are likely to lead to significant impacts on ecology and biodiversity within the study area are presented as follows:

- Construction Phase:
  - Loss of Habitat due to:
    - Clearance of vegetation, waste construction material in the 11.5 acres area;
    - Clearance of Vegetation in additional area of 5.78 acres for plant and access road and 5.5 acres for ROW of 6 km long gas pipeline; and
  - Habitat Disturbance:
    - Jetty development on Dehular Khal close to project site
    - Raising of project site by dredging Tentulia river;
    - Barge Movement for transportation of construction material
  
- Operations Phase:
  - Habitat Disturbance due to:
    - Water intake for plant operations from Dehular Khal and release of cooling tower blow down water in the same;
    - Transportation of HSD for plant operations;

## 6.2.2 Characteristics of Impacts

Based on the Interactions Matrix, the predicted impacts have been described on the basis of characteristics that together determine the magnitude of the impact. The various terminologies used to describe impact characteristics are provided subsequently in Table 6.2.

**Table 6.2** *Impact Characteristic Terminology*

Characteristics	Definition	Designations that are applicable to NBBL's Bhola II
Nature of Impact	The nature of an impact is defined as the type of change from current baseline conditions or the introduction of a new desirable or undesirable factor.	<p>Within the context of the NBBL, the nature of the impact is as follows:</p> <ul style="list-style-type: none"> <li>• <b>Positive or beneficial impact</b> when impact is considered to represent improvement to baseline condition or introduce a new desirable factor;</li> <li>• <b>Negative impact</b> when impact is considered to represent adverse change from the baseline or introduce a new undesirable factor.</li> <li>• <b>Neutra impact</b> when is considered to represent neither beneficial nor adverse changes from the baseline or introduce no desirable/ undesirable factor.</li> </ul>
Type of Impact	A descriptor indicating the relationship of the impact to the Project (in terms of cause and effect)	<p>Within the context of Bhola II, the type of the impact can be:</p> <ul style="list-style-type: none"> <li>• <b>Direct impact</b> resulting from the direct interaction between a project activity and the receiving environment (Resource/Receptor);</li> <li>• <b>Indirect impact</b> between the proposed activity</li> </ul>

Characteristics	Definition	Designations that are applicable to NBBL's Bhola II
Extent of impact	The special reach or extent of the impact from Project activities (e.g., confined to a small area around the Project Footprint, projected for several kilometres, etc.) within the area of influence (AoI)	<p>and the environment as a result of subsequent interactions within the environment, for example deforestation; or</p> <ul style="list-style-type: none"> <li>• <b>Induced impact</b> resulting from other non-project activities that happen as a consequence of the Project activities for example deforestation and clearance of vegetation leads to soil erosion and sedimentation of Dehular Canal present with in the foot print;</li> </ul> <p>The extent selected based on the understanding of the Project related activities and prevailing environmental baseline conditions include the following:</p> <ul style="list-style-type: none"> <li>• <b>Local:</b> when impact due to the proposed Project related activities is restricted within Area of Influence which has been determined as 5 km for social resources and 10 km for environmental and ecological resources. Furthermore, the area of influence is defined with respect to project activities for each component in the impact scale depending upon resource/ receptor and its interaction with the environmental, ecological and social attributes;</li> <li>• <b>Regional:</b> Impacts extend beyond the area of influence to affect regionally important environmental resources or are experienced at a regional scale as determined by administrative boundaries, (here its affects different <i>upazilla</i>);</li> <li>• <b>National:</b> Where the extent of impact is beyond the AoI to cover impacts that affect nationally important environmental resources or affect an area that is nationally important/protected or have macro-economic consequences.</li> </ul>
Duration of impact	The time period over which a resource/ receptor is affected or exposed. The duration of an impact is determined to find out whether it would be impacted temporary, short-term, long- term or permanent. The impacts have been assessed considering impact duration and time taken by an environmental component to recover/ restore back to its best achievable pre-Project state or remaining within the standards set for a component of environment.	<p>As the Project the footprints has been spatially spread across different unions with respect to the location of the power plant within Kutuba, impacts have been determined based on their temporal scale and exposure of resources or receptors as following:</p> <p><b>Temporary (very low duration)</b> impacts would last for a short duration of 1 month or less, are reversible and intermittent or occasional in nature. The resource or receptor would return to the previous state when the effect ceases or after a short period of recovery (eg. Site clearance);</p> <p><b>Short-term (low duration)</b> when impact is likely to be restricted for a duration of less than 6 months; this is based on the understanding that there will be recovery of the effected environmental component to its best achievable pre-project state within 1 year;</p> <p><b>Long-term (medium duration)</b> when impacts would continue for an extended period of time; this is based on the understanding that there will be recovery of the effected environmental component to its best achievable pre-project state within 1 to 5</p>

Characteristics	Definition	Designations that are applicable to NBBL's Bhola II
		years (inlet and outfall of water);
Scale- Intensity of Impact	The size of the impact (e.g., the size of the area damaged or impacted, the fraction of a resource that is lost or affected, etc.)	<b>Permanent (high duration)</b> when impacts would occur during the development of the Project and cause a permanent change in the affected receptor or resource that endures substantially beyond the Project lifetime (Eg. Land use change). Impact scale relates to the size of the impact. Where possible this is intended to be a numerical value or a qualitative description of "intensity".
Frequency of impact	A measure of the constancy or periodicity of the impact.	The impacts as one off or varying frequency (intended to be a numerical value or a qualitative description ) as per following classification: <b>Remote</b> – one off, when resulting remote or one off chance of an event due to an activity on a receptor/ resource;  <b>Occasional</b> -when an impact due to an activity is occurring intermittently from time to time on a receptor/resource;  <b>Periodic</b> -when an impact due to an activity is resulting on periodic basis say for a week or a month on a resource/ receptor;  <b>Routine or Continuous</b> -when an impact due to an activity is continuously resulting on a resource/ receptor
Likelihood of Impacts	Applicable to non-routine impacts arising as an unplanned or accidental events resulting in project related structure/infrastructure breakdown or catastrophic failure or external events (e.g. due to flood, glacier outburst, earthquake, dam failure, fire, extreme weather conditions) causing impact on environment resources or receptors	The impact of non-routine events is assessed in terms of the risk by taking into account both the consequence of the event and the probability of occurrence (Risk = probability x Consequence).  These risks due to unplanned activities are worked out for their acceptability further multiplying them with their likelihood  The likelihood of impacts is determined based for unplanned events or accidental events even with low probability.  The likelihood of an impact/risk has been considered as per the following criteria: <b>Unlikely</b> -when event is unlikely but may occur at some time during normal operating conditions; <b>Possible</b> - when event is likely to occur at some time during normal operating conditions; and <b>Likely</b> -when event will occur during normal operating conditions (i.e. it is essentially inevitable).

### 6.2.3

#### *Determining Magnitude of Impact*

Magnitude is typically a function of some combination (depending on the resource/receptor in question) of the following impact characteristics:

- Extent;
- Duration;
- Scale - Intensity;
- Frequency.

Additionally, for impacts resulting from unplanned events, the 'likelihood' actor has been considered together with the other impact characteristics, using qualitative scale as defined in the above table on likelihood.

Magnitude essentially describes the intensity of the change that is predicted to occur in the resource/receptor as a result of the impact. Magnitude designations themselves are universally consistent, but the descriptions for these designations vary on a resource/receptor-by-resource/receptor basis. The universal magnitude designations are:

- Positive;
- Negligible;
- Small;
- Medium;
- Large.

In the case of a positive impact, no magnitude designation (aside from 'positive') was assigned. It was considered sufficient for the purpose of the IA to indicate that the Project was expected to result in a positive impact, without characterising the exact degree of positive change likely to occur.

In the case of impacts resulting from unplanned events, the same resource/receptor-specific approach to concluding a magnitude designation was followed, but the 'likelihood' factor was considered, together with the other impact characteristics, when assigning a magnitude designation.

Definitions of magnitude for physical, biological and human environmental resources or receptors are defined subsequently:

**Table 6.3** *Magnitude Definitions for Physical, Biological & Human Resources/Receptors*

<b>Magnitude Definitions</b>	<b>Biophysical and Environmental Receptors</b>	<b>Socio-economic, Cultural and Community Health Receptors</b>
Negligible	Immeasurable, undetectable or within the range of normal natural variation	Change remains within the range commonly experienced within the household or community.
Small	Slight changes in background levels well within accepted norms. Emissions/ Discharges are well within benchmark discharge limits. The effected environmental conditions are expected to be recovered within a few months	Perceptible difference from baseline conditions. Tendency is that impact is local, rare and affects a small proportion of households and is of a short duration.
Medium	Temporary or localised change in	Clearly evident difference from

Magnitude Definitions	Biophysical and Environmental Receptors	Socio-economic, Cultural and Community Health Receptors
	physical or biological environment. The recovery of such changes returning to background levels thereafter and / or Occasional exceedance of benchmark emission/ discharge limits	baseline conditions. Tendency is that impact affects a substantial area or number of people and/or is of medium duration. Frequency may be occasional and impact may be regional in scale.
Large	Change over a large area or ecological conditions that lasts over the course of several months with quality likely to cause secondary impacts; and / or routine exceedance of benchmark emission/ effluent discharge limits	Change dominates over baseline conditions. Affects the majority of the area or population in the Area of Influence and/or persists over many years. The impact may be experienced over a regional or national area.
Positive	In the case of positive impacts, no magnitude is assigned, unless there is ample data to support a more robust characterization. It is usually sufficient to indicate that the Project will result in a positive impact, without characterizing the exact degree of positive change likely to occur.	

#### 6.2.4

#### *Sensitivity/Vulnerability/Importance of Resource/Receptor*

In addition to characterising the magnitude of impact, the other principal impact evaluation step was definition of the sensitivity/ vulnerability/ importance of the impacted resource/ receptor. There are a range of factors that was taken into account when defining the sensitivity/ vulnerability/ importance of the resource/ receptor, which may be physical, biological, cultural or human. Other factors were also considered when characterising sensitivity/ vulnerability/ importance, such as legal protection, government policy, National and International standards, funding agencies guidelines stakeholder views and economic value. The sensitivity/ vulnerability/ importance designations used herein for all resources/ receptors are:

- Low
- Medium
- High

In the social and community health context, vulnerability is the accepted term for describing the sensitivity of the social receptor that will experience the impact. A vulnerable individual (or group) is one that could experience adverse impacts more severely than others, based on his/her status (for example poverty status, access to basic goods and services). Vulnerability is a pre-existing status that is independent of the Project. It is important to understand the vulnerability context as it will affect the ability of the social receptor to adapt to any changes brought about by the Project (directly or indirectly). A higher level of vulnerability can result in increased susceptibility to negative impacts or a limited ability to take advantage of positive impacts. A project may also exacerbate existing vulnerabilities if the status of individuals and communities and their coping mechanisms are not adequately understood or considered.



Definitions as to determine sensitivity/importance/ vulnerability of environmental resource or receptor are defined as follows:

**Table 6.4** *Definitions of Sensitivity/Importance/Vulnerability Biophysical and Human*

Sensitivity	Biophysical and Environmental Receptors	Socio-economic, Cultural and Community Health Receptors
Low	Existing physical environment quality is good and the ecological resources that it supports are not sensitive to disturbance	Minimal vulnerability; consequently with a high ability to adapt to changes brought by the Project and opportunities associated with it.
Medium	Existing physical environment quality shows some signs of stress and/ or supports ecological resources that could be sensitive to change in quality or physical disturbance.	Some, but few areas of vulnerability; still retaining an ability to at least in part adapt to change brought by the Project and opportunities associated with it.
High	Physical environment quality is already under stress and/ or the ecological resources it supports are very sensitive to change	Profound or multiple levels of vulnerability that undermine the ability to adapt to changes brought by the Project and opportunities associated with it.

ERM Impact Assessment Standards defines sensitivity of ecological receptors by determining the significance of effects on species and habitats separately. The impact assessments were undertaken based on following impact assessment matrix as presented in *Table 6.5* and *Table 6.6* respectively.

**Table 6.5** *Habitat-Impact Assessment Criteria*

Habitat Sensitivity/ Value		Magnitude of Effect on Baseline Habitats			
		Negligible	Small	Medium	Large
Negligible	Habitats with negligible interest for biodiversity.	Not significant	Not significant	Not significant	Not significant
Low	Habitats with no, or only a local designation / recognition, habitats of significance for species listed as of Least Concern (LC) on IUCN Red List of Threatened Species, habitats which are common and widespread within the region, or with low conservation interest based on expert opinion.	Not significant	Not significant	Minor	Moderate

Habitat Sensitivity/ Value		Magnitude of Effect on Baseline Habitats			
		Negligible	Small	Medium	Large
Medium	Habitats within nationally designated or recognised areas, habitats of significant importance to globally Vulnerable (VU) Near Threatened (NT), or Data Deficient (DD) species, habitats of significant importance for nationally restricted range species, habitats supporting nationally significant concentrations of migratory species and / or congregatory species, and low value habitats used by species of medium value.	Not significant	Minor	Moderate	Major
High	Habitats within internationally designated or recognised areas; habitats of significant importance to globally Critically Endangered (CR) or Endangered (EN) species, habitats of significant importance to endemic and/or globally restricted-range species, habitats supporting globally significant concentrations of migratory species and / or congregatory species, highly threatened and/or unique ecosystems, areas associated with key evolutionary species, and low or medium value habitats used by high value species.	Not significant	Moderate	Major	Critical
Negligible	Effect is within the normal range of natural variation				
Small	Affects only a small area of habitat, such that there is no loss of viability / function of the habitat				
Medium	Affects part of the habitat, but does not threaten the long-term viability / function of the habitat.				
Large	Affects the entire habitat, or a significant proportion of it, and the long-term viability / function of the habitat is threatened.				

**Table 6.6** *Species-Impact Assessment Criteria*

Baseline Species Sensitivity/ Value		Magnitude of Effect on Baseline Habitats			
		Negligible	Small	Medium	Large
Negligible	Species with no specific value or importance attached to them.	Not significant	Not significant	Not significant	Not significant
Low	Species and sub-species of LC on the IUCN Red List, or not meeting criteria for medium or high value.	Not significant	Not significant	Minor	Moderate

Baseline Species Sensitivity/ Value		Magnitude of Effect on Baseline Habitats			
		Negligible	Small	Medium	Large
Medium	Species on IUCN Red List as VU, NT, or DD, species protected under national legislation, nationally restricted range species, nationally important numbers of migratory, or congregatory species, species not meeting criteria for high value, and species vital to the survival of a medium value species.	Not significant	Minor	Moderate	Major
High	Species on IUCN Red List as CR, or EN. Species having a globally restricted range (ie plants endemic to a site, or found globally at fewer than 10 sites, fauna having a distribution range (or globally breeding range for bird species) less than 50,000 km <sup>2</sup> ), internationally important numbers of migratory, or congregatory species, key evolutionary species, and species vital to the survival of a high value species.	Not significant	Moderate	Major	Critical
Negligible	Effect is within the normal range of variation for the population of the species.				
Small	Effect does not cause a substantial change in the population of the species, or other species dependent on it.				
Medium	Effect causes a substantial change in abundance and / or reduction in distribution of a population over one, or more generations, but does not threaten the long term viability / function of that population, or any population dependent on it.				
Large	Affects entire population, or a significant part of it causing a substantial decline in abundance and / or change in and recovery of the population (or another dependent on it) is not possible either at all, or within several generations due to natural recruitment (reproduction, immigration from unaffected areas).				

## 6.2.5

### *Determining Impact Significance*

Once magnitude of impact and sensitivity/ vulnerability/ importance of resource/ receptor have been characterised, the significance was assigned for each impact. The significance of impacts is then devised from a combination of the sensitivity of the receptor and the magnitude of impact. The overall significance is evaluated through a matrix of magnitude versus sensitivity or vulnerability/ value of resources/ receptors shown subsequently in

Figure 6.2 Impact Significance

		Sensitivity/Vulnerability/importance of Resource/Receptor		
		Low	Medium	High
Magnitude of Impact	Negligible	Negligible	Negligible	Negligible
	Small	Negligible	Minor	Moderate
	Medium	Minor	Moderate	Major
	Large	Moderate	Major	Major

The matrix applies universally to all resources/receptors, and all impacts to these resources/receptors, as the resource/receptor-specific considerations are factored into the assignment of magnitude and sensitivity/ vulnerability/ importance designations that enter into the matrix.

**Table 6.6** *Categories of Impact Significance*

Impact Category	Description of Impact Significance for Biophysical and Environmental Receptors	Description of Impact Significance for Socio-economic and Cultural Receptors	Description of Impact Significance for Community Health
Positive	Positive impacts provide resources or receptors, most often people, with positive benefits. The concepts of equity have been considered in assessing the overall positive nature of some impacts such as economic benefits, or opportunities for employment, improvement in infrastructure and overall development of region		
Negligible	An impact of negligible significance is one where a resource/receptor (including people) will essentially not be affected in any way by a particular activity or the predicted effect is deemed to be 'imperceptible' or is indistinguishable from natural background variations	Inconvenience caused, but with no consequences to livelihoods, culture or quality of life.	Receptors may experience annoyance, minor irritation, or stress associated with change; minimal impact to perceived quality of life. Does not require treatment. No long-term consequences for the health of individuals and the community.
Minor	An impact of minor significance is one where a resource/receptor will experience a noticeable effect, but the impact magnitude is sufficiently small and/or the resource/receptor is of low sensitivity/ vulnerability/ importance. In either case, the magnitude should be well within applicable standards/guidelines	Impacts are short term and temporary and do not result in long term reductions in livelihood or quality of life.	Temporary reduction to health status of certain individuals that can be easily treated and does not result in long term consequences for community health. Impacts may lead to greater health inequalities in Project area.
Moderate	An impact of <b>moderate</b> significance has an impact magnitude that is within applicable standards/guidelines, but falls somewhere in the range from a threshold below which the impact is minor, up to a level that might be just short of breaching a legal limit. The emphasis for moderate impacts is on demonstrating that the impact has been reduced to a level that is as low as reasonably practicable (ALARP).	Adverse impacts that notably affect livelihood or quality of life at household and community level. Impacts can mainly be reversed but some households may suffer long-term effects.	High risk of diseases or injuries as well as exposure to Project operational risks to the local community. May result in long term but reversible community health impacts.
Major	An impact of <b>major</b> significance is one where an accepted limit or standard may be exceeded, or large magnitude impacts occur to highly valued/sensitive resource/receptors. An aim of Impact assessment is to get to a position where the Project does not have any major residual impacts, certainly not ones that would endure into the long-term or extend over a large area. However, for some aspects there may be major residual impacts after all practicable mitigation options have been exhausted (i.e. ALARP has been applied).	Diverse primary and secondary impacts that will be impossible to reverse or compensate for, possibly leading to long-term impoverishment, or societal breakdown.	Loss of life, severe injuries or chronic illness requiring hospitalization. Exposure to and incidence of diseases not commonly seen previously in the area. Likely to have long-term consequences for community health.

## 6.2.6

### *Residual Impacts*

The residual impacts are described in terms of their significance and the nature of the impact is qualified, where appropriate, on the basis of the descriptions (e.g. short-term, localised). The criteria take into account the degree to which impacts can be quantified and compared with accepted limits and standards or a combination of the magnitude of change caused by the Project in combination with the value/sensitivity of the receptor/resource that is impacted. It is important to note that impact prediction and evaluation takes into account any embedded controls (i.e., physical or procedural controls that are already planned as part of the Project design, regardless of the results of the Impact Assessment Process).

## 6.2.7

### *Identification of Mitigation and Enhancement Measures*

Once the significance of an impact has been characterised, the next step was to evaluate what mitigation and enhancement measures are warranted. For the purposes of this IA, ERM adopted the following Mitigation Hierarchy:

- **Avoid at Source, Reduce at Source:** avoiding or reducing at source through the design of the Project.
- **Abate on Site:** add something to the design to abate the impact.
- **Abate at Receptor:** if an impact cannot be abated on-site then control measures can be implemented off-site.
- **Repair or Remedy:** some impacts involve unavoidable damage to a resource (e.g. agricultural land and forestry due to creating access, work camps or materials storage areas) and these impacts can be addressed through repair, restoration or reinstatement measures.
- **Compensate in Kind, Compensate Through Other Means:** where other mitigation approaches are not possible or fully effective, then compensation for loss, damage and disturbance might be appropriate (e.g., planting to replace damaged vegetation, financial compensation for damaged crops or providing community facilities for loss of fisheries, access, recreation and amenity space).

The priority in mitigation was to first apply mitigation measures to the source of the impact (i.e., to avoid or reduce the magnitude of the impact from the associated Project activity), and then to address the resultant effect to the resource/receptor via abatement or compensatory measures or offsets (i.e., to reduce the significance of the effect once all reasonably practicable mitigations have been applied to reduce the impact magnitude).

### *Management and Monitoring*

The final stage in the IA Process was the definition of the basic management and monitoring measures that are needed to identify whether: (a) impacts or their associated Project components remain in conformance with applicable standards/ guidelines; and (b) mitigation measures are effectively addressing impacts and compensatory measures and offsets are reducing effects to the

extent predicted. This is covered in *Section 7* under environmental and social management plan (ESMP).

### 6.3

#### *ASSESSMENT OF ENVIRONMENTAL IMPACTS - CONSTRUCTION PHASE*

Construction of the power plant will be carried out by the EPC Contractor (appointed by NBBL). The construction phase for the Project will comprise of primarily two distinct phases: (a) civil construction work that would require a minimum of one year for completion; and (b) mechanical and electrical work for Plant commissioning. The entire construction phase is expected to continue for 26 months. The approximate number of workers for both civil and mechanical works is expected to be around 1000 (during peak construction), whereas average workforce will be around 500. The workers will be sourced both locally as well as from outside. A summary of the activities with the potential to cause impacts to the surrounding environment and human receptors is presented below.

- **Site preparation:** include site clearance from existing debris/ construction material of Bhola-I CCPP, sand filling, site levelling and compaction.
- **Civil work for power plant:** Construction of Lay down areas and construction workers camp (within Project area), internal roads, site drainage, piling and excavation for foundations work, buildings, etc.;
- **Construction of a temporary jetty:** to receive construction material, machinery and heavy power plant equipment;
- **Procurement and transportation of power plant equipment:** will include Transportation of construction materials, construction machinery and equipment for the power plant through the existing access road and the temporary jetty via Dehular Khal;
- **Installation of power plant equipment:** will include installation of GTG, HRSG, STG, cooling tower, transformer, switch yard, etc.
- **Installation of gas pipeline:** 6 km long gas pipeline will be constructed from the Shahbazpur Gas Field to the site.
- **Installation of water intake structure and pipeline:** water intake pontoon at Dehular Khal and raw water pipeline from Dehular Khal to the project site.
- **Construction of on-site and off-site work facilities:** including site office, sanitation and labour accommodation
- **Construction of two oil unloading jetties:** to receive fuel oil by barges.
- **Commissioning of Combined Cycle Plant.**

#### 6.3.1

##### *Soil and Sediment Quality*

Potential sources of impacts to soil and sediment quality due to the construction phase activities include:



- Site clearance (removal of structures and disposal of scrap and other wastes from site), sand filling and levelling to raise the Project site level +4.10 m above MSL;
- Transportation of construction material, equipment and personnel;
- Storage of construction materials including hazardous material;
- Civil work activities;
- Storage, handling and disposal of wastes generated from site clearance, site excavation and formation, civil works and activities of construction workers (general waste and sewage).
- Erection of Power Plant Building.

### Criteria

For the assessment of soil and sediment quality, the sensitivity and magnitude criteria outlined in *Table 6.7* and *Table 6.8*, respectively have been used.

**Table 6.7** *Sensitivity Assessment Criteria for Soil and Sediment quality (compaction, erosion and contamination) and Landuse*

Sensitivity Criteria	Contributing Criteria	
	Environment	Social
<b>Soil and sediment Quality related criteria as compaction, erosion and contamination and Landuse change</b>	The extent to which the soil and sediment quality plays an ecosystem role in terms of supporting biodiversity. This includes its role as in supporting a lifecycle stage	The extent to which the soil and sediment quality provides a use (agricultural use, fishing) to the local communities and businesses, or is important in terms of national resource protection objectives, targets and legislation
Low	<ul style="list-style-type: none"> <li>• The soil quality does not support diverse habitat or populations and/or supports habitat or population of low quality.</li> <li>• The sediment quality does not support diverse aquatic habitat or populations and and/or supports aquatic habitat or population of low quality.</li> <li>• Designated area, No change or negligible Change from designated Landuse.</li> <li>• Minor Visual Change.</li> </ul>	<ul style="list-style-type: none"> <li>• The soil and sediment quality has little or no role in provisioning of services as agricultural uses for the local community.</li> <li>• Landuse not of relevant use by Community.</li> </ul>
Medium	<ul style="list-style-type: none"> <li>• The soil quality supports diverse habitat or population of flora and fauna and supports habitats commonly available in the Project AoI.</li> <li>• The sediment quality does not support diverse aquatic habitat and supports habitats commonly available in the waterbody across the Project AoI.</li> </ul>	<ul style="list-style-type: none"> <li>• The soil and sediment has local importance in terms of provisioning services as agricultural services but there is ample capacity and / or adequate opportunity for alternative sources of comparable quality i.e. ready availability across the AoI.</li> </ul>
	<ul style="list-style-type: none"> <li>• Perceived change from designated</li> </ul>	<ul style="list-style-type: none"> <li>• Landuse of important local use by</li> </ul>

High	landuse.	communities.
	<ul style="list-style-type: none"> <li>• Visual Change but common feature in Project AoI.</li> <li>• The soil quality supports economically important or biologically unique species or provides essential habitat for such species.</li> <li>• The sediment quality supports economically important or biologically unique aquatic species or provides essential habitat for such species.</li> </ul>	<ul style="list-style-type: none"> <li>• The soil and sediment is wholly relied upon locally, with no suitable technically or economically feasible alternatives, or is important at a regional level for provisioning services.</li> </ul>
	<ul style="list-style-type: none"> <li>• Major change in Landuse.</li> <li>• Visual Change aesthetically affecting locals.</li> </ul>	<ul style="list-style-type: none"> <li>• Landuse of regional importance. Change would impact Landuse classification of the area.</li> </ul>

**Table 6.8** *Criteria for Impact Magnitude for Assessment of Impact to Soil and Sediment Quality and Landuse*

Magnitude Criteria	Negligible	Small	medium	Large
Soil compaction and erosion	<ul style="list-style-type: none"> <li>• Qualitative-No perceptible or readily measurable change from baseline conditions</li> <li>• Scale-Localized area as Particular activity areas</li> <li>• Time-Short duration (few days) or one time as temporary</li> </ul>	<ul style="list-style-type: none"> <li>• Perceptible change from baseline conditions but likely to easily revert back to earlier stage with mitigation</li> <li>• Scale- -Project site, activity areas and immediate vicinity not impacting any sensitive receptor</li> <li>• Sort term-Only during particular activities or phase of the project lifecycle as civil works or construction phase (few months)</li> </ul>	<ul style="list-style-type: none"> <li>• Clearly evident (e.g. perceptible and readily measurable) change from baseline conditions and/or likely take time to revert back to earlier stage with mitigation</li> <li>• Scale- Project site, activity areas and immediate vicinity impacting sensitive receptor/s</li> <li>• Long term-Spread across several phases of the project lifecycle (few years)</li> </ul>	<ul style="list-style-type: none"> <li>• Major (e.g. order of magnitude) change in comparison to baseline conditions and/or likely difficult or may not to revert back to earlier stage with mitigation</li> <li>• Scale- Regional or international;</li> <li>• Permanent change</li> </ul>

Magnitude Criteria	Negligible	Small	medium	Large
Soil and sediment contamination	Well within Dutch standard <sup>1</sup> (refer Section 2.9 for Dutch guidelines)	Well within Dutch standard <sup>2</sup>	Exceeds Target Value but well within Interventional Value (Refer Table 2.11)	Exceeds Interventional Value and needs intervention. (Refer Table 2.11)
Land use	No change	Temporary	Permanent but no visual and use impact	Permanent with visual and use impact

### *Receptors*

The analysis of soil and sediment sampling in the Project area indicate that the soils are mainly sandy loam to silty loam and sediments from the Dehular Khal were of the silty clay loam type. Soil samples were found to be moderately acidic in nature (i.e. pH between 5.62 and 6.10) while the pH of sediment samples from Dehular Khal was found to be acidic in nature.

The soil at the project site contains sand depositions from the river used for filling. It does not support any diverse habitat or species and agricultural activities. Additional land to be required for power plant is currently used for agricultural activities and was having good organic content in comparison to filled area of the project site. However, as the level need to be raised upto +4.10 m above MSL, this area will also be raised. Hence, soil and sediment was considered as low under sensitivity assessment criteria.

### *Impact Significance*

#### Soil Compaction

The Project site contains sand depositions from the river used for filling to raise the height of the entire site above the highest flood level recorded. Laydown area, fabrication yard and construction camp are also planned within the Project area and hence, soil compaction will be limited to these areas within the power plant. Movement of heavy vehicles and heavy construction machinery will also cause soil compaction however a permanent access road to the Project site is already in place and being used by the existing Bhola I power plant. Furthermore an approach road will be constructed along the boundary of Bhola-I CCPP to provide access to the site

<sup>1</sup> Dutch Target and Intervention Values (Soil remediation Circular 2009-2012 Revision), <https://zoek.officielebekendmakingen.nl/stcrt-2012-6563.pdf>.

The assessment of potential impacts to soil and sediment has been considered as per the Dutch Standard as Bangladesh does not have any local standards for soil or sediment quality.

<sup>2</sup> Dutch Target and Intervention Values (Soil remediation Circular 2009-2012 Revision), <https://zoek.officielebekendmakingen.nl/stcrt-2012-6563.pdf>.

The assessment of potential impacts to soil and sediment has been considered as per the Dutch Standard as Bangladesh does not have any local standards for soil or sediment quality.

from the entrance of Bhola-I Project. Soil compaction and possible damage to the soil structure due to heavy vehicular movement will only be limited to the vicinity of gas pipeline route and Project site. The pipeline routes cut across a mix of agricultural land, fallow land not used for cultivation as well as along existing infrastructure facilities such as access roads. The overall route is likely to follow the existing BPDB gas pipeline corridor. The area identified for temporary jetty was already being used in the past by Bhola I for unloading and transportation of heavy lifts during the commissioning of plant. Based on the impact magnitude assessment criteria as given in *Table 6.8* the impact was assessed as **negligible**.

Impact	<i>Soil Compaction</i>				
Impact Nature	Negative	Positive		Neutral	
Impact Type	Direct	Indirect		Induced	
Impact Duration	Temporary	Short-term	Long-term		Permanent
Impact Extent	Local	Regional		International	
Impact Scale	Limited to Project Site, gas pipeline RoW and temporary jetty site vicinity as well as areas identified for laydown and construction workers camp (within project site). Main access road and access to temporary jetty location, valve station and water intake location already exist.				
Frequency	Primarily during Civil work				
Impact Magnitude	Positive	Negligible	Small	Medium	Large
Resource/ Receptor Sensitivity	Low	Medium		High	
Impact Significance	Negligible	Minor	Moderate	Major	
	Significance of impact is considered <b>negligible</b> .				

### Soil erosion

The project AOI is prone to soil erosion due to nature of soil (which will be filled to raise the site level) enhanced by heavy rains in the area. Average annual rainfall based on rainfall data recorded at Bhola for last 45 years is 2297.4 mm. Of the annual rainfall, about 80% fall during five monsoon months (May to September) with June and July getting the maximum rains. As mentioned earlier, the project site within the complex is already raised and is having retaining wall to control any surface runoff (refer to pictures below). However, additional sand filling of about 200,000 m<sup>3</sup> will be required in order to maintain the site level above +4.10 m from MSL as well as to raise the additional land acquired for the project towards the northern site. Without proper compaction and guarding of the filled sand, soil erosion may occur from the site during heavy rains. Soil erosion will typically be worse during the monsoon months during the initial site preparation and compaction works. As per the project design, it is planned to construct retaining wall to protect any runoff from the site. Furthermore, sand filling activity is not planned during the monsoons season to avoid any soil erosion due to excessive rains.



Based on the impact magnitude assessment criteria as given in *Table 6.8* the impact was assessed as **negligible**.

Impact	<i>Soil Erosion</i>				
Impact Nature	Negative	Positive		Neutral	
Impact Type	Direct	Indirect		Induced	
Impact Duration	Temporary	Short-term	Long-term		Permanent
Impact Extent	Local	Regional		International	
Impact Scale	Project site and access road				
Frequency	Primarily during Civil work				
Impact Magnitude	Positive	Negligible	Small	Medium	Large
Resource/ Receptor Sensitivity	Low		Medium		High
Impact Significance	Negligible	Minor	Moderate	Major	
	Significance of impact is considered <b>negligible</b> .				



Soil and Sediment Contamination (Spills and Leaks)

Soil contamination during the construction phase may result from leaks and spills of oil, lubricants, fuel from heavy equipment or leakage from chemical/fuel storage. Sediment contamination may take place during the construction of the temporary jetty and unloading of heavy equipment. Such spills can have long-term impact on soil and sediment quality, but are expected to be localised in nature. While the risk of accidental spillage of potentially hazardous substances is low, proper handling and disposal of contaminated materials will further reduce the risk if such event does take place. The following prevention and mitigation measures will be proposed in the Specification Manual for EPC Contractors:

- The Contractor will prepare unloading and loading protocols for the temporary jetty and train staff to prevent spills and leaks
- The Contractor will prepare guidelines and procedures for immediate clean-up actions following any spillages of oils, fuels or chemicals;
- A site specific Emergency Response Plan will be prepared by the Contractor for soil clean-up and decontamination

Soil and sediment samples analysis indicates that the soil/fill material at the Project site and Dehular Khal is not contaminated. Spill control measures such as storage and handling of chemicals and fuels on impervious areas (such as concrete surfaces) will be implemented to minimize impacts in case of spills. Loaders to be used near the temporary jetty will be checked for lubricant leaks and workers trained not to dispose of waste in the area. Liquid effluents arising from construction activities will be treated to the standards specified in *Schedule 9 and 10 of ECR, 1997 of the GOB (Table 2.8 and Table 2.9)*; and the applicable World Bank/IFC guidelines (*Table 2.8*) prior to discharge. Therefore, the likelihood of unplanned events (i.e. spills and leaks) leading to soil and sediment contamination is considered likely. Based on the impact magnitude assessment criteria as given in *Table 6.8* and impact has been considered as **minor**.

Impact	<i>Soil and Sediment contamination from spills and leaks</i>				
Impact Nature	Negative	Positive	Neutral		
Impact Type	Direct	Indirect		Induced	
Impact Duration	Temporary	Short-term	Long-term	Permanent	
Impact Extent	Local	Regional		International	
Impact Scale	Limited to Project Site and temporary jetty				
Frequency	Limited to construction Phase primarily during transportation, handling and storage of materials, waste and equipment installation				
Likelihood	Likely				
Impact Magnitude	Positive	Negligible	Small	Medium	Large
Resource/ Receptor Sensitivity	Low	Medium		High	
Impact Significance	Negligible	Minor	Moderate	Major	
	Significance of impact is considered <b>minor</b> .				

### Soil Contamination from Waste Handling

Soil may become contaminated due to improper handling and storage of waste. The majority of the generated wastes will be non-hazardous. General construction waste will comprise of surplus or off-specification materials such as concrete, steel cuttings/filings, wooden planks, packaging paper or plastic, wood, plastic pipes, metals, etc. During the construction phase of the Project, solid waste generation will mainly be concrete waste and bitumen. It is estimated that approximately 100 – 150 m<sup>3</sup> of such waste will be produced. The inert wastes will be stored near the proposed project site and will be reused under floors or under road to increase the California Bearing Ratio (CBR)<sup>1</sup> value. Bitumen or any hazardous wastes will be disposed off to licensed contractors. Domestic wastes consisting of food waste, plastic, glass, aluminium cans and waste packages will also be generated by the construction workforce.

A small proportion of the waste generated during construction will be hazardous and may include:

- Used paint, engine oils, hydraulic fluids and waste fuel;
- Spent solvents from equipment cleaning activities; and
- Spent batteries or spent acid/alkali from the maintenance of machinery on site.

If improperly managed, hazardous waste may create impacts on land. With reference to similar projects, it is anticipated that the quantity of hazardous waste (mainly waste lubricant oil and waste paints/solvents) will be less than 100 litres per month. The construction contractor will handle, store and dispose of all waste in accordance with applicable GOB guidelines. Concrete waste of inert nature will be stored near the concrete batching plant and will be reused under floors or internal roads. Any bitumen waste will be stored separately in lined areas to be disposed-off to licensed contractors. There is a potential for direct, long-term negative impacts to soil quality from improper waste handling; however, with the implementation of the mitigation measures discussed above the impacts to soil quality as discussed in **Table 6.8** is assessed to be **negligible**.

Impact	<i>Soil Contamination from Waste Handling</i>			
Impact Nature	Negative	Positive	Neutral	
Impact Type	Direct	Indirect	Induced	
Impact Duration	Temporary	Short-term	Long-term	Permanent
Impact Extent	Local	Regional	International	
Impact Scale	Limited to Project Site			

<sup>1</sup> The **California Bearing Ratio (CBR)** is a penetration test for evaluation of the mechanical strength of road subgrades and base courses.



Frequency	Limited to construction Phase primarily during transportation, handling and storage of waste				
Likelihood	Likely				
Impact Magnitude	Positive	Negligible	Small	Medium	Large
Resource/ Receptor Sensitivity	Low		Medium		High
Impact Significance	Negligible	Minor	Moderate	Major	
	Significance of impact is considered <b>negligible</b> .				

### *Mitigation Measures*

Potential impacts to soil and sediment during the construction phase are attributed to soil compaction, erosion and soil /sediment contamination from spills and leaks and wastes.

The following measures will be implemented to mitigate potential soil compaction and erosion:

- All areas of excavation shall be closed and compacted before the monsoon season to prevent soil erosion.
- Storm water shall be properly channelized to settling tanks for controlling soil erosion.
- Demarcating routes for movement of heavy vehicles;
- Stripping and placing soils when dry, and not when wet;
- Building small bunds in areas with slope to prevent soil erosion.

The following measures will be implemented for the storage and handling of chemicals and to minimise impacts to soil/sediment:

- Fuel tanks and chemical storage areas will be sited on sealed areas and provided with locks to prevent unauthorized entry;
- Use of spill or drip trays to contain spills and leaks;
- Use of spill control kits to contain and clean small spills and leaks.
- The storage areas of oil, fuel and chemicals will be surrounded by bunds or other containment device to prevent spilled oil, fuel and chemicals from percolating into the ground or reaching the receiving waters;
- The Contractor will prepare unloading and loading protocols for the temporary jetty and train staff to prevent spills and leaks
- The Contractor will prepare guidelines and procedures for immediate clean-up actions following any spillages of oils, fuels or chemicals;
- A site specific Emergency Response Plan will be prepared by the Contractor for soil clean-up and decontamination; and
- The construction contractor will implement a training program to familiarise staff with emergency procedures and practices related to contamination events.

The measures in place to properly manage waste and thereby minimize any impacts to soil and sediment quality are:

- Design processes to prevent/ minimise quantities of wastes generated and hazards associated with the waste generated;
- Training labourers for waste disposal in designated areas and use of sanitation facilities;
- Proper storage of the construction materials and wastes to minimise the potential damage or contamination of the materials; and
- Implementation of construction materials inventory management system to minimise over-supply of the construction materials, which may lead to disposal of the surplus materials at the end of the construction period.
- Segregation of hazardous and non-hazardous waste and provision of appropriate containers for the type of waste type (e.g. enclosed bins for putrescible materials to avoid attracting pests and vermin and to minimise odour nuisance);
- Storage of wastes in closed containers away from direct sunlight, wind and rain;
- Storage of waste systematically to allow inspection between containers to monitor leaks or spills;
- Ensuring that storage areas have impermeable floors and containment, of capacity to accommodate 110% of the volume of the largest waste container; and
- Disposal of waste by licensed contractors.

#### *Residual Impacts*

Criterion	Rating pre mitigation	Rating post mitigation	Remark
<i>Soil and Sediment contamination from spills and leaks</i>			
Residual Impact	Minor	Negligible	With implementation of the precautionary and the mitigation measures mentioned for the storage and handling of chemicals and to avoid / minimise impacts to soil/sediment the residual impact would be negligible.

### 6.3.2

#### *Water Resources*

The potential sources of impact to surface and ground water resources are:

- Excavation activities at the Project site and for gas pipeline RoW may increase the erosion, especially during rainfall, which may increase the suspended sediment concentrations and pollute water sources. Similar impacts are possible from construction of the temporary jetty for receiving heavy equipment, construction material etc.;
- Sewage generated from the construction workforce (toilets). Liquid effluents will be generated from washing of construction equipment and vehicles;
- Commissioning phase testing of pipelines and wastewater generation; and

- Inappropriate storage of waste leading to water quality impacts from runoff entering the adjoining channel to the Project site or seepage to ground water.

*Criteria*

For the assessment of water resources, the sensitivity and magnitude criteria outlined in *Table 6.9* and *Table 6.10* have been used respectively.

**Table 6.9: Sensitivity Assessment Criteria for Water Resources (Surface water and Ground water)**

Sensitivity Criteria	Contributing Criteria	
	Environment	Social
Water Resources -Surface water and ground water (quality/quantity related criteria)	The extent to which the water resource plays an ecosystem or amenity role in terms of supporting biodiversity either directly or indirectly, particularly with respect to dependent ecosystems.	The extent to which the water resource provides or could provide a use (drinking water, agricultural uses, washing and other domestic or industrial, use as waterways) to the local communities and businesses, or is important in terms of national resource protection objectives, targets and legislation.
Low	The water resource does not support diverse aquatic habitat or populations, or supports aquatic habitat or population that is of low quality.	The water resource has little or no role in terms of provisioning services as agricultural water source, other domestic uses as washing, bathing, industrial use and waterways for the local community.  The groundwater resource is not currently abstracted and used in the vicinity of the Project, but is of sufficient quality and yield to be used for that purpose in the future (and there is a reasonable potential for future use).
Medium	The water resource supports diverse populations of flora and / or fauna but available in the surface water bodies in the region.	The surface water resources have local importance in terms of provisioning services but there is ample capacity and / or adequate opportunity for alternative sources of comparable quality. The groundwater resource is an important water supply, and is currently used, but there is capacity and / or adequate opportunity for alternative sources of comparable quality.

Sensitivity Criteria	Contributing Criteria	
High	The water resource supports economically important or biologically unique aquatic species or provides essential habitat for such species	<p>The surface water resources are wholly relied upon locally, with no suitable technically or economically feasible alternatives, or is important at a regional or transboundary watershed level for provisioning services</p> <p>The groundwater resource is wholly relied upon locally, with no suitable technically or economically feasible alternatives, or is important at a regional or national level for water supply or contribution to groundwater dependent ecosystems (e.g. transboundary rivers).</p>

**Table 6.10** *Criteria for Impact Magnitude for Assessment of Impact to Surface and Ground water Resources*

Magnitude Criteria	Negligible	Small	Medium	Large
General Criteria	No perceptible or readily measurable change from baseline conditions.	Perceptible change from baseline conditions but likely to be within applicable norms and standards for mode of use.	Clearly evident (e.g. perceptible and readily measurable) change from baseline conditions and / or likely to approach and even occasionally exceed applicable norms and standards for mode of use.	Major changes in comparison to baseline conditions and / or likely to regularly or continually exceed applicable norms and standards for mode of use.
Water Quality	Discharges are expected to be well within statutory limits*	Discharges are expected to be within statutory limits*	Occasional breach(es) of statutory discharge limits (limited periods) expected*	Repeated breaches of statutory discharge limits (over extended periods) expected*
	Groundwater quality be well within ambient levels or allowable criteria**	Groundwater quality be within ambient levels or allowable criteria** or may exceed for 1-2 parameters which is common occurrence due to geological regime	Groundwater quality exceeds ambient levels or allowable criteria** for key parameters.	Groundwater quality exceeds ambient levels or allowable criteria**.
	Abstractions from or discharge to aquifer(s) are		Abstraction or discharge to aquifer(s) are	Abstractions or discharge to aquifer(s) are expected to cause

Magnitude Criteria	Negligible	Small	Medium	Large
	unlikely to cause water quality issues.	of the area. Abstraction or discharge to aquifer(s) may cause small but local changes in water quality in the aquifer system. These can be considered potential short-term localized effects on groundwater quality which is likely to return to equilibrium conditions within a short (months) timeframe.	expected to cause potential localized effects on groundwater quality which are likely to be fairly long lasting and / or give rise to indirect ecological and / or socio-economic impacts.	potentially severe effects on groundwater quality which are likely to be long-lasting (e.g. years or permanent) and / or give rise to indirect ecological and / or socio-economic impacts.
Water Quantity	<p>There is likely to be negligible (less than 1% of lean season flow) or no consumption of surface water by the Project at any time</p> <p>There is likely to be negligible or no abstraction, use of or discharge to the groundwater by the Project at any time.</p>	<p>The Project will consume surface water, but the amounts abstracted are likely to be relatively small in comparison to the resource available at the time of use (i.e. taking into account seasonal fluctuation)</p> <p>The Project will consume groundwater or deliver discharge to groundwater, but the amounts abstracted / discharged are likely to be relatively small in comparison to the resource available at the time of use (i.e. taking into account seasonal fluctuation).</p>	<p>The Project will consume surface water, and the amounts abstracted are likely to be significant in comparison to the resource available at the time of use (i.e. taking into account seasonal fluctuation)</p> <p>The Project will consume groundwater or discharge to groundwater, and the amounts abstracted / discharged are likely to be significant in comparison to the resource available at the time of use (i.e. taking into account seasonal fluctuation).</p>	<p>The Project will consume surface water, and the amounts abstracted are likely to be very significant in comparison to the resource available at the time of use (i.e. taking into account seasonal fluctuation)</p> <p>The Project will consume groundwater or discharge to groundwater, and the amounts abstracted / discharged are likely to be very significant in comparison to the resource available at the time of use (i.e. taking into account seasonal fluctuation).</p>

\*The quality assessment of potential impacts to surface water has considered according to Schedule 9 of ECR, 1997 of the GOB and the World Bank/IFC General EHS Guidelines (refer to *Table 2.9*).

\*\*The quality of groundwater was compared with Schedule 3 (B) (Standards for drinking water) of ECR 1997 of the GOB.

## Receptors

The major surface water body adjacent to the Project site is Dehular Khal. This will be used as means of transport for heavy equipment and temporary jetty constructed on it. Details of the hydrology and drainage pattern in the AOI are discussed in *Section 4.3.5*.

Based on the sensitivity assessment criteria described in *Table 6.9* both surface and ground water resource was found to be medium.

## Impact Significance

### Wastewater Discharge

Wastewater will be generated from washing of equipment and machinery on site. This wastewater may contain suspended solids and traces of hydrocarbon. The contractor will be responsible for ensuring that any wastewater discharged meets the standards stipulated in *Schedule 10 of ECR, 1997* and the applicable *World Bank/ IFC General EHS Guidelines* prior to discharge of such wastewater. Sanitary facilities including toilets will be provided for the use of the construction workforce both on-site and at the workers' accommodation. Such sewage streams are likely to be high in organic matter, suspended solids, coliform and other pollutants. Septic tanks will be provided to treat sanitary wastewater. As per the hydrogeological observations, the groundwater is unconsolidated soil pore water of Quarternary and the depth of groundwater is shallow from the ground (about 0.5 m during wet season), however during dry season the groundwater level descends and the fluctuation is in the range of 1 to 2 m. Considering the shallow ground water table, water tight septic tank floor will be constructed. The contractor will be responsible for ensuring periodic desludging<sup>1</sup> of the septic tank and that any wastewater discharges meet the standards stipulated in *Schedule 9 of ECR, 1997* and the applicable *World Bank/ IFC General EHS Guidelines* (refer to *Table 2.8* and *Table 2.9*) prior to discharge of such wastewater, if required. Potential impacts are expected to be short-term and localised in nature. Based on the above discussion and referring to the magnitude criteria in *Table 6.10*, the impact to surface water from wastewater discharges during construction is assessed to be **minor**.

Impact	Wastewater discharge			
Impact Nature	Negative	Positive	Neutral	
Impact Type	Direct	Indirect	Induced	
Impact Duration	Temporary	Short-term	Long-term	Permanent
Impact Extent	Local	Regional	International	
Impact Scale	Limited to discharge outside the project boundary on Dehular Canal			

<sup>1</sup> Frequent desludging inhibits the anaerobic action in the septic tank. Therefore, the tank shall be cleaned when the tank is filled more than 60% of the depth of the tank.

Frequency	Limited to construction Phase –washing of machinery, equipment, use of sanitation facilities, cleaning of pipelines				
Impact Magnitude	Positive	Negligible	Small	Medium	Large
Resource/ Receptor Sensitivity	Low		Medium	High	
Impact Significance	Negligible	Minor	Moderate	Major	
	Significance of impact is considered <b>minor</b> .				

### Groundwater Contamination

Groundwater contamination during the construction phase may occur from unplanned events such as leaks and spills of oil, lubricants, fuel from heavy equipment, improper handling of sewage or chemical/fuel storage. Mitigation measures such as storage of chemicals at concreted laydown areas will be implemented to minimize contamination in the event of a spill. Septic tanks will be provided to treat sanitary wastewater. As stated above, all wastewater discharges will meet the standards stipulated in *Schedule 9 and 10 of ECR, 1997* and the applicable *World Bank/ IFC General EHS Guidelines* prior to discharge. While there is a potential for long-term direct impacts to groundwater quality from construction, with the implementation of mitigation measures for proper handling of chemicals, waste and liquid effluents, impact to ground water would be limited. Based on the above discussion and referring to the magnitude criteria in Table 6.10, the impact to groundwater from spills and leaks is assessed to be **minor**.

Impact	<i>Ground water contamination</i>				
Impact Nature	Negative		Positive	Neutral	
Impact Type	Direct		Indirect	Induced	
Impact Duration	Temporary	Short-term	Long-term	Permanent	
Impact Extent	Local		Regional	International	
Impact Scale	Limited to Project site, ancillary areas and jetty site				
Frequency	Limited to construction Phase and unplanned events as leaks, spills, sewage discharge				
Likelihood	Likely				
Impact Magnitude	Positive	Negligible	Small	Medium	Large
Resource/ Receptor Sensitivity	Low		Medium	High	
Impact Significance	Negligible	Minor	Moderate	Major	
	Significance of impact is considered <b>minor</b> .				

### Mitigation Measures

The following measures will be implemented to reduce impacts to surface water and groundwater:

- Vehicle servicing areas and wash bays will, as far as practical, be located within roofed and cemented areas. The drainage in these covered areas



will be connected to oil/water separator and channelized properly to the land/inland waters ;

- Oil leakage or spillage will be contained and cleaned up immediately. Waste oil will be collected and stored for recycling or disposal;
- Oil and grease separator shall be used for wastewater generated from cleaning activities;
- Any surplus wastewater from the concrete batching will be treated to comply with discharge standards before it is discharged to the Dehular Khal;
- Adequate sanitary facilities, i.e. toilets and showers, will be provided for the construction workforce;
- Workers will be trained in the use of designated areas/bins for waste disposal and encouraged to use toilets.
- Septic tanks will be provided to treat sanitary wastewater with arrangement of periodic desludging; and
- All sewage and liquid effluent will be treated to meet the standards specified in *Schedules 9 and 10 of the ECR, 1997* respectively and *IFC EHS Guidelines* prior to discharge to land/inland waters.

#### *Residual Impacts*

Criterion	Rating pre mitigation	Rating post mitigation	Comment
<b>Wastewater discharge</b>			
Residual Impact	Minor	Negligible	With implementation of the precautionary and the mitigation measures mentioned for prevention of surfacewater contamination the residual impacts would be negligible.
<b>Groundwater contamination</b>			
Residual Impact	Minor	Negligible	With implementation of the precautionary and the mitigation measures mentioned for prevention of groundwater contamination the residual impacts would be negligible.

### 6.3.3

#### *Air Quality*

##### *Sources of Impact*

The potential sources of impacts to air quality are as follows:

- Site preparation and levelling;
- Excavation of soil to create building and equipment foundations;
- Pile driving for the equipment foundation;
- Exhaust emission from movement of heavy equipment by barge, heavy loaders, trucks;
- Loading and unloading of materials,
- Installation of gas pipeline;
- Concreting works, including operation of concrete batching plant, which will be located away from sensitive receptors and additional net fencing on

section of boundary wall facing the residential receptors to reduce dust transport;

- Operation of diesel generators and other diesel based construction machineries.
- Dust generated from stockpiles of materials, waste, loose earth, handling and moving excavated material and transporting wastes on vehicles.

Dust generated from many of these activities will increase the particulate matter levels in ambient air. Vehicles and equipment exhaust emissions can lead to increases in levels of nitrogen oxides (NO<sub>x</sub>), sulphur dioxide (SO<sub>2</sub>), particulate matter (PM<sub>10</sub> and PM<sub>2.5</sub>), volatile petroleum hydrocarbon constituents and carbon monoxide (CO), which are key pollutants of concern with respect to human health.

#### Criteria

For the assessment of air quality, the sensitivity and magnitude criteria outlined in Table 6.11 and Table 6.12 respectively have been used.

The standards considered for assessment of potential impacts to air quality, are *Schedule 11 ECR, 1997 of the GOB (Table 2.7)*. The air quality impacts associated with the construction activities have been assessed qualitatively, using professional judgement and based on past experience from similar projects.

**Table 6.11** *Sensitivity Criteria for Air quality*

Sensitivity Criteria	Contributing Criteria	
Low	<p><i>Human Receptors</i> Locations where human exposure is transient.<sup>1</sup></p>	<p><i>Ecological Receptors</i> Locally designated sites; and/or areas of specific ecological interest, not subject to statutory protection (for example, as defined by the project ecology team).</p>
Medium	<p>Locations where the people exposed are workers <sup>2</sup>, and exposure is over a time period relevant to the air quality objective for PM<sub>10</sub> (in the case of the 24-hour objectives, a relevant location would be one where individuals may be exposed for eight hours or more in a day<sup>3</sup>).</p>	<p>Nationally designated sites.</p>
High	<p>Locations where members of the public are exposed over a time period relevant to the air quality objective for PM<sub>10</sub> (in the case of the 24-hour objectives, a</p>	<p>Internationally designated sites.</p>

<sup>1</sup> As per the GOB and World Bank/IFC guidelines, there are no standards that apply to short-term exposure, eg one or two hours, but there is still a risk of health impacts, albeit less certain.

<sup>2</sup> Notwithstanding the fact that the air quality objectives and limit values do not apply to people in the workplace, such people can be affected to exposure of PM10. However, they are considered to be less sensitive than the general public as a whole because those most sensitive to the effects of air pollution, such as young children are not normally workers. For this reason workers are included in the medium sensitivity category.

<sup>3</sup> *Schedule 11 ECR, 1997 of the GOB and the World Bank/IFC General EHS Guidelines (Table 2.7)*.

Sensitivity Criteria	Contributing Criteria
	relevant location would be one where individuals may be exposed for eight hours or more in a day).

**Table 6.12** *Criteria for Impact Magnitude for Assessment of Impact to Air Quality (Construction Phase)*

Magnitude Criteria	Negligible	Small	medium	Large
Air Quality	<ul style="list-style-type: none"> <li>Total site area &lt; 500 m<sup>2</sup>;</li> <li>Soil type with large grain size (e.g. sand); and/or</li> <li>Total material moved &lt; 5,000 tonnes.</li> </ul>	<ul style="list-style-type: none"> <li>Total site area 500 m<sup>2</sup> to 2,500 m<sup>2</sup>;</li> <li>Soil type with large grain size (e.g. sand); and/or</li> <li>Total material moved 5,000 to 20,000 tonnes.</li> </ul>	<ul style="list-style-type: none"> <li>Total site area 2,500 m<sup>2</sup> to 10,000 m<sup>2</sup>;</li> <li>Moderately dusty soil type (e.g. silt); and/or</li> <li>Total material moved 20,000 to 100,000 tonnes.</li> </ul>	<ul style="list-style-type: none"> <li>Total site area &gt; 10,000 m<sup>2</sup>;</li> <li>potentially dusty soil type (e.g. clay, which will be prone to suspension when dry due to small particle size); and</li> <li>Total material moved 100,000 tonnes.</li> </ul>

### *Receptors*

From the landuse analysis and field study, it is clear that most of the land surrounding the Project site is agricultural land and vegetation covered area. On the immediate east, there is existing power plant (225 MW Bhola I) followed by settlement, which is approximately 150 m from the proposed project site. The immediate south of the Project site has barren land followed by agricultural land. The immediate north site of the Project site has agricultural land followed by village (approximately 100 m from the Project site). The immediate west site of the Project site has Dehular Khal followed by agricultural land and settlement (approximately 500 m from the Project site). As can be referred from Table 6.11 and above discussion, the human receptors were assessed to be of Medium sensitivity, whereas ecological receptors were considered as of Low sensitivity.

### *Impact Significance*

#### Dust Generation

Most of the construction activities mentioned above have the potential to generate dust. The extent of impacts from dust will depend on the exact location of these activities and on the weather conditions; stronger winds and dry conditions will enhance the transfer of dust, while damp or wet conditions will reduce this impact. Construction dust dispersion is expected to be localised due to the relatively high mass of the dust particles which will tend to confine the most significant dust impacts to the area within 100 m of the source. The potential for dust emissions during the wet season will be small,

due to the moistening of any dust by rainfall. During the dry season, dust suppression techniques will be used and stockpiles will be covered to minimise fugitive dust emissions from spoil storage.

As the dust is expected to settle within 200 m and dust suppression techniques will be practiced, the main receptors would be workers on site and neighbouring plant and people living near the access road.

On the basis of the above factors and the magnitude criteria described in Table 6.12, and considering the high levels of SPM and PM<sub>10</sub> recorded during the baseline monitoring in the surrounding areas, the magnitude of the impact associated with the emission of dust during construction activities is predicted to be medium and the significance of the impacts is assessed to be **moderate**.

Impact	<i>Air quality degradation due to dust generation</i>				
Impact Nature	Negative	Positive	Neutral		
Impact Type	Direct	Indirect		Induced	
Impact Duration	Temporary	Short-term	Long-term	Permanent	
Impact Extent	Local	Regional		International	
Impact Scale	Within 100 m from project boundary and within 100 m from access road				
Frequency	Limited to civil works in Construction Phase and storage and handling of construction material (sand, cement etc.)				
Impact Magnitude	Positive	Negligible	Small	Medium	Large
Resource/ Receptor Sensitivity	Low		Medium		High
Impact Significance	Negligible	Minor	Moderate		Major
	Significance of impact is considered <b>moderate</b> .				

### Exhaust Emissions

Heavy equipment such as excavators, cranes, and compactors will be used onsite. Emissions from these equipment and diesel generator sets used to generate power will cause impacts to ambient air quality. Transportation of construction material by barges and other transport vehicles per hour during daytime will also contribute to exhaust emissions.

Impacts from vehicle emissions decrease rapidly with increasing distance from the source and are not likely to be significant at distances of more than 200 m from the source; they are usually minor at a distance of more than 50 m with limited no. of vehicles plying the access road. The distance between the Project site boundary and the closest residential dwelling is approximately 10 m. However there are a few settlements located along the access road. It is also to be noted that all construction material will be transported by waterway and hence, access road will be used mainly for site access and transportation of personnel.

The implementation of the good site practices, such as the regular maintenance of vehicles and equipment, using cleaner fuels and switching off

vehicles when not in use will reduce exhaust emissions from the operation of the diesel-powered construction equipment and therefore minimise adverse air quality impacts. Based on the above discussion and Table 6.12, the air quality impacts associated with the vehicular and equipment emissions during construction activities are assessed to be of **moderate** potential significance, as few dwellings are located within 100 m from the northern project site boundary.

Impact	<i>Air quality degradation due to exhaust emissions</i>				
Impact Nature	Negative	Positive	Neutral		
Impact Type	Direct	Indirect		Induced	
Impact Duration	Temporary	Short-term	Long-term	Permanent	
Impact Extent	Local	Regional		International	
Impact Scale	Within 100 m from project boundary and within 100 m from access road				
Frequency	Limited to Construction Phase primarily due to transportation of material and use of heavy machinery and DG sets				
Impact Magnitude	Positive	Negligible	Small	Medium	Large
Resource/ Receptor Sensitivity	Low	Medium		High	
Impact Significance	Negligible	Minor	Moderate	Major	
	Significance of impact is considered <b>moderate</b> .				

### *Mitigation Measures*

The mitigation measures listed below will be implemented to ensure that air quality impacts during the construction phase are as low as reasonably practicable.

To reduce dust impacts, the following measures will be put in place:

- Implementation of a regular watering and sprinkling dust suppression regime, during the dry season;
- Concrete batching plant will be located within the project site and to keep it away from sensitive receptor/s;
- No stockpiles shall be maintained outside project site, and maximum possible distance between the stockpiles and receptors will be maintained;
- Covering and/or watering of all stockpiles of dusty materials such as excavated spoils to avoid fugitive dust emissions;
- During construction, the approach road will be kept clean, free from mud and slurry.
- Black topping of the access road during the construction phase itself to reduce dust generation; and
- Waste from construction will not be burned.

Exhaust emissions will be minimized as follows:

- The movement of construction vehicles will be minimised and a 20 km/hr speed limit will be enforced around the construction site;
- All diesel-powered equipment will be regularly maintained and idling time reduced to minimise emissions;

- Low sulphur diesel (S<0.5%) will be used in diesel powered equipment in collaboration with best management practices;
- Vehicle / equipment air emissions will be controlled by good practice procedures (such as turning off equipment when not in use); and
- Vehicle / equipment exhausts observed emitting significant black smoke in their exhausts will be serviced/ replaced.

#### *Residual Impacts*

Criterion	Rating pre mitigation	Rating post mitigation	Comment
<b>Air Quality Degradation due to dust generation</b>			
Residual Impact	Moderate	Minor	With implementation of the precautionary and the mitigation measures mentioned for prevention/reduction of dust generation the residual impacts would be minor.
<b>Exhaust Emissions</b>			
Residual Impact	Moderate	Minor	With implementation of the precautionary and the mitigation measures mentioned for minimizing exhaust emissions the residual impacts would be minor.

#### 6.3.4

#### *Noise*

##### *Sources of Impact*

The potential sources of noise during the construction phase of the Project include equipment, machinery and transportation used for the construction activities. The heavy equipment used for the construction activities will be the major sources of noise. This will include piling and preparing concrete foundations for major plant and buildings. There is expected to be an increase in traffic and thereby in traffic noise impacts to receptors near the existing access road from the transportation of equipment, construction materials and workers. To minimise these impacts, only those vehicles meeting the standards stipulated in *Schedule 5* of the *Environmental Conservation Rules, 1997* will be used.

Construction works are expected to last for 24 months. As per the *Master Specifications*, the Contractor is required to seek permission from the authorities to carry out construction works at night (2100 to 0600) on weekdays.

The detailed breakdown of activities is not available at this stage, and as the Contractor has not yet been appointed, no construction plant inventory is available at the time of assessment. Therefore, an assumed plant inventory is provided in *Table 6.13*. Assumptions have made regarding the type, number and Sound Power Levels (SPLs) of construction plant, based on similar projects and publicly available data. It has been assumed that only one of each type of plant will be on-site during any day or night period. Re-

assessment of noise levels may be required if the actual plant inventory and SPL vary from the assumed list.

**Table 6.13 Assumed Construction Equipment Sound Pressure Level Inventory**

Construction Equipment	SPL, dB(A)
Bulldozer	115
Backhoe	96
Impact pile driver	101
Loaders	108
Vibratory roller	102
Fuel truck	104
Welding machine	101
Cranes	106
Dump truck	105
Grader	114
Fork lifts	112
Compressors	104
Generators	93

Source: The SPLs of the construction equipment have been taken from DEFRA Construction Noise database for prediction of noise on construction and open sites, July 2006 and ERM's internal database

Although construction equipment and materials will be delivered by road from the nearby railway station/ temporary jetty, which will result in slight increase in heavy traffic movement and thereby in traffic noise impacts to receptors near the access road. To minimise these impacts, only those vehicles meeting the standards stipulated in *Schedule 5 of the Environmental Conservation Rules, 1997* will be used.

#### Criteria

The noise impact assessment was conducted with reference to Bangladesh *Environmental Conservation Rules, 1997* and the *IFC EHS Guidelines*. Details of the standards are presented in **Table 2.10**. Furthermore, for the assessment of ambient noise, the sensitivity and magnitude criteria outlined in Table 6.14 and Table 6.15, respectively have been used:

**Table 6.14 Sensitivity Assessment Criteria for Ambient Noise Impacts**

Sensitivity Criteria		Contributing Criteria
Ambient Noise	Human receptor	Ecological Receptor
Low	Industrial Use	Locally designated sites; and/or areas of specific ecological interest, not subject to statutory protection (for example, as defined by the project ecology team).
Medium	Residential and Recreational Space	Nationally designated sites.
High	Educational/ Religious/ Medical Facilities	Internationally designated sites.



**Table 6.15 Magnitude Assessment Criteria for Ambient Noise Impacts**

Magnitude Criteria	Negligible	Small	medium	Large
Noise	<ul style="list-style-type: none"> <li>Predicted noise levels are at or less than 3 dB (A) above the relevant limits / thresholds*.</li> <li>Short term exposure (Few hours in a day and not continuous)</li> </ul>	<ul style="list-style-type: none"> <li>Predicted noise levels are 3 to less than 5 dB (A) above the relevant limits / thresholds*.</li> <li>Short term exposure (&lt; 1 month)</li> </ul>	<ul style="list-style-type: none"> <li>Predicted noise levels are between 5 and 10 dB (A) above the relevant limits / thresholds*.</li> <li>Medium Term Exposure (1 to 6 months)</li> </ul>	<ul style="list-style-type: none"> <li>Predicted noise levels are more than 10 dB (A) above the relevant limits / thresholds*.</li> <li>Long term exposure (&gt; 6 months)</li> </ul>

\*Note: reference to Bangladesh Environmental Conservation Rules, 1997 and the IFC EHS Guidelines presented in Table 2.10.

### Receptors

Baseline noise monitoring was carried out at nine locations. The results of baseline monitoring indicated that ambient noise levels at residential areas were high compared to the applicable standards. The nearest receptor is located at 60 m from the Project boundary, which will be exposed to noise from construction activities. Apart from this the settlements located close to the access road will also be affected due to the movement of vehicles.

As can be referred from Table 6.14 and above discussion, the receptors as well as the ecological receptors were assessed to be of Low sensitivity, whereas the human settlements in the surrounding areas (residential areas) were assessed to be of Medium sensitivity.

### Impact Significance

**Methodology:** The environmental noise prediction model SoundPLAN 7.2 was used for modelling noise emissions from the construction equipment. The operation of construction equipment with 80% usage scenario was modelled to cover the construction phase. As a conservative approach to the assessment, atmospheric absorption during sound transmission was not included in the assessment. In addition, to represent a worst-case scenario for the assessment, all construction equipment was assumed to be operating simultaneously. Attenuation due to the boundary wall of the power generation complex that has already been constructed has been considered in the modelling.

**Predicted Noise Levels at Receptors:** The predicted noise levels within the Project AOI during day and night time are presented in Figure 6.3 and Figure 6.4, respectively. Predicted noise levels at 9 receptors (where baseline noise levels were also monitored) have been presented in Table 6.16.

Figure 6.3 Predicted Construction Noise Levels during Daytime ( $Leq_{day}$ )

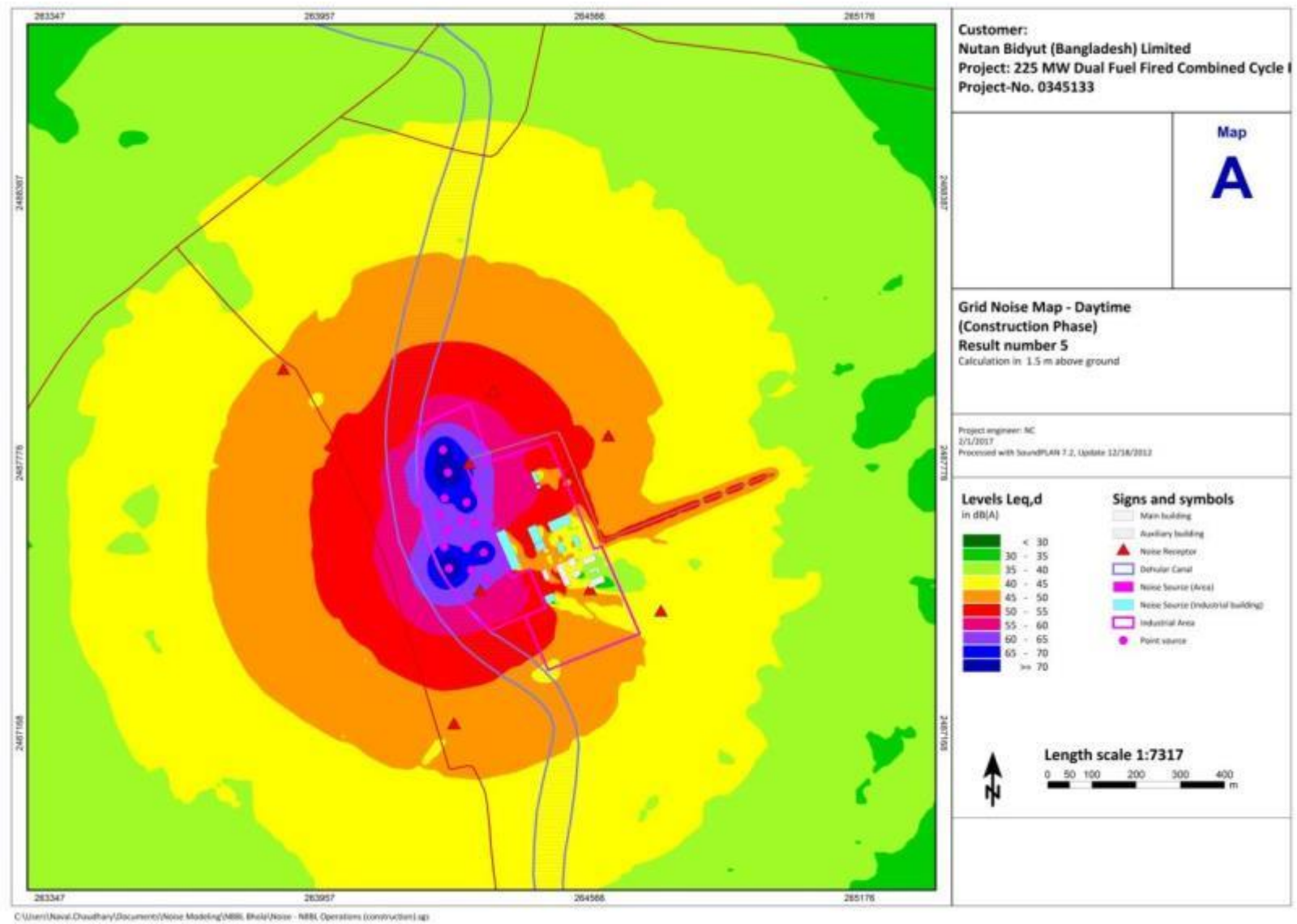
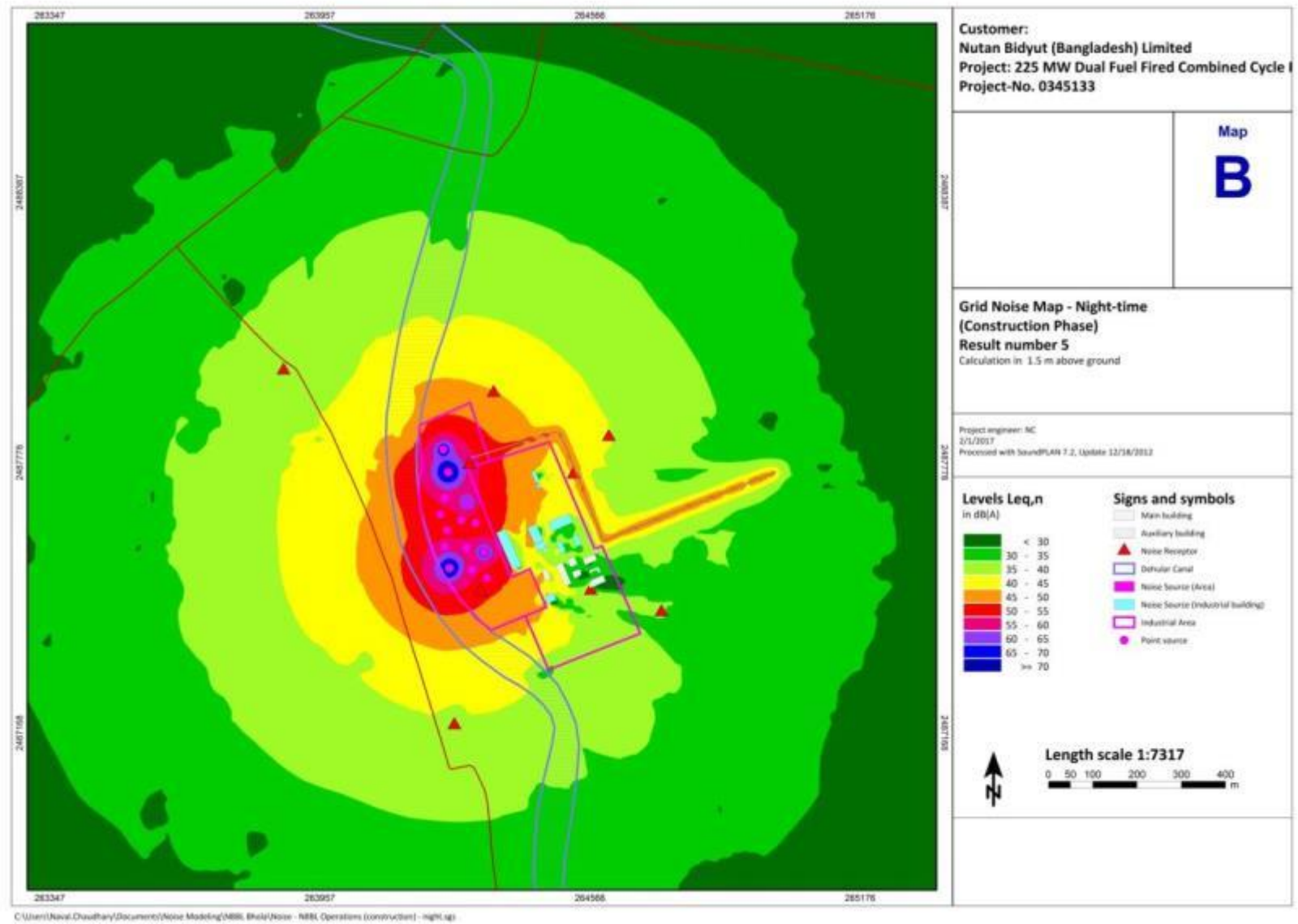


Figure 6.4 Predicted Construction Noise Levels during Night time ( $Leq_{day}$ )



**Table 6.16 Predicted Noise Levels at Noise Receptors during Construction Phase**

Receptor Code	Approximate Distance to Power complex Boundary (m) and Direction from Project Site	Baseline Sound Pressure Levels at Receptors, Leq (dBA) <sup>(1)</sup>		Predicted Sound Pressure Levels at Receptors, Leq (dBA)		Total Sound Pressure Level (Baseline + Predicted), Leq (dBA)		Applicable Standard (dB(A)) <sup>(2)</sup> <sup>(3)</sup> as per Landuse	
		Leq <sub>d</sub> *	Leq <sub>n</sub> *	Leq <sub>d</sub>	Leq <sub>n</sub>	Leq <sub>d</sub>	Leq <sub>n</sub>	Leq <sub>d</sub>	Leq <sub>n</sub>
NL1	130 (E)	53.5	51.0	48.2	40.1	54.6	51.3	55	45
NL2	Complex boundary	65.4	66.1	51.3	45.5	65.6	66.1	70	70
NL3	10 (N)	62.1	54.4	53.4	45.2	62.6	54.9	55	45
NL4	60 (E)	58.3	53.0	43.3	35.2	58.4	53.1	55	45
NL5	within complex	56.9	53.0	47.0	38.9	57.3	53.2	70	70
NL6	within complex	46.3	46.0	60.1	51.9	60.3	52.9	70	70
NL7	within complex	64.8	63.2	65.5	57.3	68.2	64.2	70	70
NL8	230 (SW)	56.8	49.0	45.1	36.9	57.1	49.3	55	45
NL9	340 (NW)	53.9	49.4	42.7	34.5	54.2	49.5	55	45

<sup>(1)</sup> Ambient noise levels as monitored during the baseline survey

<sup>(2)</sup> Environmental Conservation Rules, 1997 (Schedule 4) amended September 7, 2006

<sup>(3)</sup> IFC/WB EHS Guidelines: Noise Management dated April 30, 2007 gives, Noise level guidelines for Residential; institutional and educational receptors in daytime (07:22:00) and night time (22:00-7:00) as 55 and 45 one hour Leq dBA respectively. For industrial and commercial receptors it is 70 one hour Leq dBA for both night and day time.

It is evident from Table 6.16 that ambient noise levels due to construction activities will be well within the applicable standard during day time at 6 receptors and night time at 4 receptors, out of total 9 receptors considered in the study. All the exceedances are due to already higher baseline noise levels during day and night time, whereas predicted noise levels were found to be meeting applicable standards with respect to land use criteria. The noise impact from construction activity during day time is expected to be **negligible** to **minor**. Furthermore, noise levels at night time will be slightly higher than the applicable standard (with < 5 dBA increase from the applicable standard) at 6 locations. Due to this the noise impact from construction activity during night time is expected to be **minor** to **moderate**.

Impact	<i>Noise from Construction Activities and transportation of man/ material (Daytime)</i>			
Impact Nature	Negative	Positive	Neutral	
Impact Type	Direct	Indirect	Induced	
Impact Duration	Temporary	Short-term	Long-term	Permanent
Impact Extent	Local	Regional	International	
Impact Scale	Within 500 m of Project site and 100 m along the access road			
Frequency	Limited to construction Phase and noise generating construction activities			
Impact Magnitude	Positive	Negligible	Small	Medium
Receptor Sensitivity	Low	Medium	High	
Impact Significance	Negligible	Minor	Moderate	Major
	Significance of impact is considered <b>negligible</b> to <b>minor</b> .			

Impact	<i>Noise from Construction Activities and transportation of man/ material (Night time)</i>			
Impact Nature	Negative	Positive	Neutral	
Impact Type	Direct	Indirect	Induced	
Impact Duration	Temporary	Short-term	Long-term	Permanent
Impact Extent	Local	Regional	International	
Impact Scale	Within 500 m of Project site and 100 m along the access road			
Frequency	Limited to construction Phase and noise generating construction activities			
Impact Magnitude	Positive	Negligible	Small	Medium
Receptor Sensitivity	Low	Medium	High	
Impact Significance	Negligible	Minor	Moderate	Major
	Significance of impact is considered <b>minor</b> to <b>moderate</b> .			

### Mitigation Measures

The following mitigation measures will be implemented to minimise potential noise impacts during the construction phase in all periods:

- Normal working hours of the contractor will be between 06:00 and 21:00 hours from Monday to Sunday. If work needs to be undertaken outside

these hours, it should be limited to activities that do not exceed the noise criteria at nearby noise sensitive receptors;

- Only well-maintained equipment will be operated on-site;
- Regular maintenance of equipment such as lubricating moving parts, tightening loose parts and replacing worn out components should be conducted;
- Machinery and construction plant that may be in intermittent use (e.g. trucks) shall be shut down or throttled down during non-work periods;
- Low noise equipment shall be used as far as practicable;
- The number of equipment operating simultaneously shall be reduced as far as practicable;
- Equipment known to emit noise strongly in one direction should be orientated so that the noise is directed away from nearby NSRs as far as practicable;
- Noisy plant (such as breakers and rollers) shall be located as far away from receptors as practicable.

### *Residual Impacts*

Criterion	Rating pre mitigation	Rating post mitigation	Comment
<b>Change in Ambient Noise Levels during daytime</b>			
Residual Impact	Negligible to Minor	Negligible	With implementation of the precautionary and the mitigation measures mentioned for prevention/reduction in noise generation at source impacts would be negligible.
<b>Change in Ambient Noise Levels during night time</b>			
Residual Impact	Minor to Moderate	Negligible to Minor	With implementation of the precautionary and the mitigation measures mentioned for minimizing the noisy activities at night time and limiting the construction activities upto suggested time span, the residual impacts would be negligible to Minor.

### 6.3.5 *Ecological Impacts*

#### *Habitat Loss due to construction activities*

##### Context

The project site and additional required area (11.5 acres+5.78 acres) land will be required to be raised to the existing Power plant level.

This will require filling of the existing and proposed land by fine sand up to required level. The filling material is proposed to be dredged from Tentulia River and transported to project site.

The 6 km pipeline route comprising of 5.5 acres will be cleared by vegetation removal and excavated for pipeline laying.



### Receptor

The project site of 11.5 acre land is already demarcated by a boundary. The current usage of site is depicted in **Figure 4.36**. The abandon scrap and waste construction debris is provides artificial habitat to species such as Bengal Monitor, Yellow Monitor (NT as per IUCN:2016.v3) and snake species as mentioned in the **Annex O**.

The project site does not coincide with any of the 3 Turtle species egg laying habitats (including one CR species). Local consultations with fishermen have indicated the rare presence of juveniles of Gharial (CR-IUCN 2016:3) in Dehular canal. (Please refer to Annex S Critical Habitat Assessment for Critically Endangered Species from AoI)

### Embedded Controls

The vegetation clearance shall be kept minimal to the extent required.

### Significance of Impacts

The construction areas are devoid of any natural habitats. Species like Bengal Monitor and Yellow Monitor Lizards (NT as per IUCN:2016.v3) and other reptiles were observed to use the waste scrap as their habitat. They are frequently seen in the homestead plantation which provides them cover as well as hunting ground for food. Site clearance will may lead to habitat loss. The nature of impact is negative, impact type is both direct at the project site, additional areas and pipeline areas and direct to the species within the RoW and indirectly to those which were the RoW is a corridor for movement.. The impact will be short term as the activities will be limited for the construction period and the extent will be local. Resource sensitivity is Low for for habitat due to absence of any protected areas and medium for species due to presence of Near Threatened species. Hence the impact significance is **Negligible** for Habitats and **Minor** for species.

**Table 6.17** *Impact due to Habitat Loss*

Impact	Habitat Loss				
Impact Nature	Negative	Positive	Neutral		
Impact Type	Direct	Indirect		Induced	
Impact Duration	Temporary	Short-term	Long-term	Permanent	
Impact Extent	Local	Regional		International	
Impact Scale	Limited to Project site, additional area and RoW of transmission line (specifically construction areas)				
Frequency	Construction phase				
Likelihood	Likely				
Impact Magnitude	Positive	Negligible	Small	Medium	Large
Resource Sensitivity (Habitat)	Low	Medium		High	
Resource Sensitivity (Species)	Low	Medium		High	
Impact Significance	Negligible	Minor	Moderate	Major	



	Significance of impact is considered <b>Negligible for Habitats</b> and <b>Minor for Species</b>				
Residual Impact Magnitude	Positive	Negligible	Small	Medium	Large
Residual Impact Significance	Negligible	Minor	Moderate	Major	
	Significance of impacts is considered <b>Negligible</b>				

The residual impacts can be minimized from **Minor** to **Negligible** by implementation of the following mitigation measures.

Mitigation measures,

- Pre-construction survey for the project site by Herpetofaunal experts is required and clearance of existing scrap material should be done with support of a certified snake catcher for rescue of any species found. Similar arrangement should be made for the pipeline RoW.
- Pre- construction surveys of bird nest before vegetation removal in the RoW of pipeline should be under taken;
- Land clearing will be kept minimum to the extent practicable for the approach road and gas pipeline;
- Wherever feasible, changes in the alignment of gas pipeline will be made to avoid felling of larger trees and any impacts to village ponds.
- Wherever feasible, depending upon availability of space within plant and/or along the access road, plantation activities shall be performed.
- Engage with local forest department and Upazilla administration for plantation activities outside the project area.
- Preference to the local workers will be given in construction activities to avoid pressure on the natural resources;
- Strict instruction should be given to the construction workers not to cut rees from the nearby areas for their fuel and timber use;
- Hunting and trapping of wild animals should be prohibited by the work force and should be bounded by contractual obligations;
- Use of LPG/ Kerosene for cooking needs to be encouraged in order to reduce the impacts on vegetation from the vicinity of the Project site;
- Compaction and stabilization will be resorted to during filling to ensure
- that no top soil is washed away; and

*Habitat Disturbance due to project activities*

Context

Transportation of machinery and construction material to the project site will be under taken by Dehular Khal. A floating Jetty will be used for offloading the material at the Project site. There is a likelihood of accidental spillage of oil and other chemicals during unloading activities and also from the storage during construction phase. This may reach the Dehular Khal directly or by runoff and impact the aquatic flora and fauna. The barge movement in Dehular Khal for transportation of heavy machinery is not an unprecedented impacts over the aquatic biodiversity of Khal, currently the Khal is used for transportation of man and material from outside Bhola Island to the island. Similarly, the dredging in Tentulia river for raising the project site above high

flood level is also not unprecedented. The dredging along the Tentulia river was experienced as a regular phenomenon for requirement of construction sand within Bhola Island. Dredging will increase the turbidity at local level but will be equalise with ambient within an short duration of time and distance. The current Khal traffic and Dredging activities are represented in *Figure 6.5*

**Figure 6.5** *Traffic at Dehular Khal and Dredging Activities in Tentulia river*



Source: ERM Ecological Survey, 13<sup>th</sup> -17<sup>th</sup> April 2016

Receptor

There are reports of Juvenile Gharial (*Gavialis gangeticus*) seen in the Dehular Khal by the local fishermen who undertake fishing in the Khal. The Khal does not present a suitable habitat for Gharial as it has steep eroded banks. It is more likely that the species is more common in Tentulia River as it has vast char lands which suit this species for basking and egg laying. Their presence in the Dehular Khal can be accidental and stray or mistaken for other species such as Water monitor Lizard (Refere *Annex S*), hence the critical habitat available in the AoI for Gharial is ruled out. Dehular Khal is used as a navigational channel and for fishing. However fishing is on a very limited scale. Fishing in Khal is limited for Shrimps (*Macrobrachium rosenbergii*) which are reportedly abundant in Khal (Figure 6.6). Beside Shrimp, the baseline survey has enumerated 70 species of fishes from Dehular Khal out of total 90 fish species in AoI, but their numbers are envisaged to be low due to disturbances such as movement of Launch Ferry boat and dredging vessels to collect sand from the Tentulia River. Major fishing is undertaken in Tentulia River. Two-spot Barb (*Puntius ticto*) Vulnerable as per IUCN red list 2016.v3 is also reported from Khal.

**Figure 6.6** *Fishing Activities from Dehular Khal*



Giant Fresh Water Shrimp

Fishing activities in Dehular Khal



Consultations for likely fish species in the Khal



Discussions on Likely locations of fishing

Source: ERM Ecological Survey, 13<sup>th</sup> -17<sup>th</sup> April 2016

### Embedded Controls

Control movement of project vessels will be undertaken in construction phase as and when required.

### Significance of Impacts

Dehular Khal is known for habitat of for 70 species of fishes including Two-spot Barb (*Puntius ticto*) an IUCN Vulnerable 2016.v3 species. The construction period will be 24 months and there will be barge trawler movement for project construction material and machinery transportation and offloading at the project site. Accidental spillage of oil and chemical may lead to habitat disturbance. A floating jetty is proposed in Dehular Khal and requirement of dredging is envisaged close to the project site to achieve the desired draft for vessel movement. This activity will also lead to habitat disturbance. The predicted impact due to habitat disturbance is negative in nature, and will impact directly due to barge/vessel movement and indirectly due to contamination during accidental spillage. Impact will be short term as it will be limited to construction period and the impact extent will be local as it will be within the Dehular Khal. The impact magnitude will be small as it is limited to AoI. The resource sensitivity will be low for habitats due to absence of any natural habitats, and medium for species due to presence of IUCN listed Vulnerable species. Impact significance based on **Table 6.18** is **Negligible** for habitats and **Small** for species.

**Table 6.18** *Impact due to Habitat Disturbance*

Impact	Habitat Disturbance				
Impact Nature	Negative	Positive		Neutral	
Impact Type	Direct	Indirect		Induced	
Impact Duration	Temporary	Short-term	Long-term	Permanent	
Impact Extent	Local	Regional		International	
Impact Scale	Limited to Project site, Dehular Khal, Temporary Jetty area				
Frequency	Construction phase				
Likelihood	Likely				
Impact Magnitude	Positive	Negligible	Small	Medium	Large
Resource Sensitivity (Habitat)	Low	Medium		High	

Resource Sensitivity (Species)	Low	Medium	High		
Impact Significance	Negligible	Minor	Moderate	Major	
	Significance of impact is considered for <b>Negligible</b> for Habitats and <b>Minor</b> and Species				
Residual Impact Magnitude	Positive	Negligible	Small	Medium	Large
Residual Impact Significance	Negligible	Minor	Moderate	Major	
	Significance of residual impacts is considered <b>Negligible</b> for Habitat and Species				

The residual impacts on species can be minimized from **Minor** to **Negligible** by implementation of following mitigation measures.

Mitigation measures,

- In case of bank erosions due to movement of barges and vessels used during construction and/or operation phases, NBBL shall invest in bank protection at both sides between Kheya Ghat to the project site as the movement of large barges and vessels will create swells and may erode the Khal banks and increase the turbidity in Khal;
- The ideal time to enter the Khal by vessels should be preferably mid-afternoon as during this time the faunal activity reduces;
- Pre-construction surveys should be undertaken by a Gharial Expert of the Dehular Khal to ascertain its presence; Any mitigation measures as agreed by SP Infra should be implemented during construction phase;
- Migratory bird survey should also be undertaken to ascertain impact of project activity on them;
- SP Infra should promote local fish breeding sites in consultation with Fishery Department with community involvement to conserve the fish resources in the Dehular Khal.

**6.4 ASSESSMENT OF ENVIRONMENTAL IMPACTS - OPERATION AND MAINTENANCE PHASE**

The assessment of operational phase impacts includes those arising both from routine operations and maintenance of the power plant, including the gas and HSD supply systems. An activity-impact interaction matrix for the operation phase of the Project is presented in Table 6.1.

**6.4.1 Soil and Sediment Quality**

*Contamination of soil and sediment from wastes*

The potential sources of waste generation during operation of the Power plant are from the following:

- Office and Canteens;
- WTP, ETP and STP;

- Gas Turbines;
- Laboratories;
- GT Compressors;
- Lube oil systems;
- DG sets; and
- Power house and workshop area.

#### Criteria

Bangladesh is having rules and regulations for waste management, which are covered under Hazardous Wastes and Ship Breaking Waste Management Rules, 2011. This will also apply to the Project.

#### Receptors

Land around the Project site is mostly fallow or agricultural. A natural drainage channel is located adjacent to the project site on western side. Improper storage, handling and disposal of solid and hazardous waste may lead to contamination of the land and water bodies nearby. In addition, waste can generate odour and cause health hazards to employees and communities nearby. Referring to sensitivity criteria described in *Table 6.7*, the receptor soil and sediment has been assessed low.

#### *Impact Significance*

The impact assessment of the wastes generated from the sources identified above is summarized below:

#### Generation of Non-Hazardous Solid Waste

The type and approximate volume of non-hazardous solid waste anticipated from operational activities will be as follows:

- Office and kitchen, 5,000 kg/year;
- Dewatered STP sludge from the WTP, ETP and STP sludge, 50 - 70 kg/year; and
- Air filters from the gas turbines, 300 kg/year.

The unplanned storage and disposal of these wastes may have a direct impact on land and water resources. The solid and non-hazardous wastes generated from the various areas during operations will be collected and segregated at the point of generation and stored in proper designated areas and disposed of through waste disposal contractors or authorized recyclers.

#### Generation of Hazardous Waste

The type and approximate volume of hazardous waste anticipated from operational activities will be as follows:

- Chemical waste generated, 300 m<sup>3</sup>/year;
- Chemical Cleaning waste from the CT compressor, 300 l/year;
- Waste/used oil from the power house and workshop, 1.5 to 2.0 m<sup>3</sup>/year;
- Dewatered sludge from the WTP and ETP, 150-200 kg/year; and

- Oil/dust contaminated cloths and rags from the lube oil system and spill kit waste, 500 kg/year.

These hazardous wastes, if haphazardly stored, may be incompatible in nature and can result in ignition, generation of toxic fumes etc. In addition, improper handling, storage and disposal can cause spillage or leachate generation, which in turn can contaminate the land and ground water.

It is planned that hazardous wastes generated from the proposed Project will be collected and stored in designated roofed-areas and/or barrels with concrete flooring and secondary containment and disposed of/ sold through contractors or treated prior to discharge.

Given the planned embedded controls, i.e. segregation measures, collection and disposal by licensed waste collectors, dedicated storage areas with secondary containment, the impacts magnitude during operation as a result of solid and hazardous waste generation is assessed as *small*.

Impact	<i>Contamination of Soil and Sediment from Wastes</i>				
Impact Nature	Negative		Positive	Neutral	
Impact Type	Direct	Indirect		Induced	
Impact Duration	Temporary	Short-term	Long-term	Permanent	
Impact Extent	Local	Regional		International	
Impact Scale	Limited to Project Site Surroundings and nearby communities				
Frequency	Not Applicable				
Likelihood	Likely				
Impact Magnitude	Positive	Negligible	Small	Medium	Large
Resource/ Receptor Sensitivity	Low		Medium	High	
Impact Significance	Negligible	Minor	Moderate	Major	
	Significance of impact is considered <b>negligible</b> .				

#### *Mitigation Measures*

In addition to the proper collection, storage and disposal options the following steps will be taken further to manage hazardous wastes:

- Wastes will be stored in a manner that will prevent contact between incompatible wastes i.e. post compatibility checks,
- Proper labelling of hazardous wastes;
- Special care will be taken in the storage areas to prevent any spillage of hazardous wastes and restrict access (except for trained staff) to such areas;
- Periodic audits will be carried out for such areas and containers; also on the segregation and collection systems and the findings will be documented and appropriate action taken against irregularities;



- A spill response plan and emergency plan will be prepared to address accidental spillages or release of hazardous wastes; and
- A proper manifest record will be maintained of waste travelling/ removed from the site; and
- Disposal of hazardous waste by engaging DOE approved waste management agencies.

## 6.4.2 *Water Resources*

### *Sources of Impact*

The potential sources of impact to surface and ground water resources during the operational phase include:

- The discharge of effluent and sewage from the operational plant that may have an impact on land or the quality of surface water; and
- The abstraction of ground water for drinking purposes for the employees of the power plant.

### *Criteria*

For the assessment of water resources, the sensitivity and magnitude criteria outlined in Table 6.9 and Table 6.10 have been used respectively. The assessment of potential impacts to surface water has considered *Schedule 3 (a), 9 and Schedule 10 of ECR, 1997 and IFC EHS guidelines for thermal power plants and general guidelines (refer to Table 2.8 and Table 2.9)*. For groundwater, *Schedule 3 (b) of ECR, 1997*, standards for drinking water has been considered.

### *Receptors*

**Surface water:** The source of water would be the Dehular Khal. Based on the sensitivity criteria Table 6.9, surface water resource is assessed as Medium.

**Groundwater:** Ground water samples analysis indicate high levels of iron with other parameters being within standard permissible limits for drinking water specified by Bangladesh ECR, 1997 Schedule 3 (B). Groundwater is used by local residents in the area for drinking. Based on the sensitivity criteria Table 6.9, ground water resource is assessed as Medium.

### *Impact Significance*

#### *Surface water abstraction*

About 384 m<sup>3</sup>/hr of water will be abstracted for the Dehular Khal for the proposed plant. This may result in:

- Reduced availability of water to downstream users;
- Affect the sustainability of the Project due to non availability of water in lean season;
- Result in changes in to the morphology of the adjacent Channel; and



- Cause ecological effects.

The feasibility report by BPDB mentions a bathymetric survey carried out for the Dehular Canal to obtain cross section, bank line, discharge and water level data. The average discharge was calculated as 108 m<sup>3</sup> per second. The proposed water requirement is estimated to be 0.11 m<sup>3</sup> per second (384 m<sup>3</sup>/hr).

This amount is only 0.1% of the flow of the Dehular Khal; the amount of intake is negligible in the context of flow of the channel. Therefore based on the impact magnitude criteria described in Table 6.10 and referring to above discussion, the impact of water abstraction on Dehular Khal for the proposed plant would be **negligible**.

Impact	<i>Impact from Surface Water Abstraction</i>				
Impact Nature	Negative	Positive	Neutral		
Impact Type	Direct	Indirect		Induced	
Impact Duration	Temporary	Short-term	Long-term	Permanent	
Impact Extent	Local	Regional		International	
Impact Scale	Downstream of Dehular Khal and Project area				
Frequency	Throughout Operation Phase				
Impact Magnitude	Positive	Negligible	Small	Medium	Large
Resource/ Receptor Sensitivity	Low		Medium	High	
Impact Significance	Negligible	Minor	Moderate	Major	
	Significance of impact is considered <b>negligible</b> .				

#### Water Pollution from Wastewater Discharge

Approximately 75 m<sup>3</sup>/hr of effluent will be discharged from the plant to the Dehular Khal after treatment. The sources of liquid effluent generation in the Plant include:

- Oily effluents from Steam turbine building, Combustion turbine building, Transformer yard of CTG and STG, Compressor and CCW pump house, Emergency DG set area, HSD Storage Tank Farm;
- HRSG blow down;
- Sampling rack waste;
- CTG auxiliary CTBD;
- CTG washing;
- HRSG washing;
- Filters (service water filtration plant) back wash; and
- CW side stream filter backwash.

Theses discharges may have a direct impact on the water quality which in turn would have ecological implications.

As discussed in *Section 3.4.10* and in the water balance (*Figure 3.6*) all the wastewater generated at various areas of the Project will be segregated at the source of generation according to their type. Similar wastewater types will be collected at one point before treatment and then treated to meet the requirements for disposal or reuse as per the GOB Environment Conservation Rule (1997) Schedule 10 (Standards for Waste from Industrial Units or Project Waste) and the applicable World Bank Group environmental requirements (which ever more stringent).

In addition, instrumentation will be used to monitor the Plant’s compliance with discharge limits. In the event that effluent discharge is detected above the effluent discharge limit criteria, isolation valves will automatically close and stop the discharge. The overall impact to the surface water quality with the treatment prior to disposal on natural drainage channel and magnitude criteria described in Table 6.10 is assessed as **negligible**.

Impact	Wastewater Discharge				
Impact Nature	Negative	Positive		Neutral	
Impact Type	Direct	Indirect		Induced	
Impact Duration	Temporary	Short-term	Long-term	Permanent	
Impact Extent	Local	Regional		International	
Impact Scale	Discharge into natural drainage				
Frequency	Not Applicable				
Impact Magnitude	Positive	Negligible	Small	Medium	Large
Resource/ Receptor Sensitivity	Low	Medium		High	
Impact Significance	Negligible	Minor	Moderate	Major	
	Significance of impact is considered <b>negligible</b> .				

#### Mitigation Measures

The following mitigation measures are suggested to minimize the impact on river water quality;

- Monitoring of temperature at the discharge point at a frequency of every 15 days;
- Discharge system shutdown in event that discharge temperature of effluent exceeds standard;
- Efforts to be made to increase the cycle of concentration to reduce the volume of blow down and consequently the volume of make-up water required by the cooling tower.
- Storm water drainage and waste water of similar nature from different units will be treated in accordance to *GOB Environment Conservation Rule (1997) Schedule 10 (Standards for Waste from Industrial Units or Project Waste)* and the applicable World Bank Group environmental requirements and World Bank/IFC guidelines.
- In the unlikely event water percolation does not occur as expected, the Project Company (PCO) could rely on temporary solutions such as to

engage a sub-contractor to use the portable pumps & hoses to evacuate this water to the river or dry canal, thereby allowing a larger surface area for the water to percolate.

- The PCO will monitor the wastewater discharge and if water stagnation is observed to persist continuously over an extended period of [12-18] months, then the PCO will evaluate permanent solutions to resolve the issue. However if the water stagnation is observed to occur for only part of the year, then the temporary solution should suffice.

Groundwater contamination

There is a risk of impacts to groundwater quality from the storage and handling of hazardous materials in the Project AOI. The hazardous materials to be stored at the site will include acids, alkalies, diesel fuel, maintenance oils and lubricants, etc. for the water treatment plant, process plant operation, and the laboratory. The maximum volume stored will be 2 tonnes each of hydrochloric acid, caustic lye. The hazardous materials will be stored in a dedicated room at the water treatment plant area. HSD to be used as secondary fuel for power generation will be stored in two tanks with capacity equivalent to 15 days operation at 80% output on HSD. Diesel for emergency DG sets will be stored in above ground oil tanks located in the vicinity of the Emergency DG set. The storage arrangements will include secondary containment measures and spill kits for spillage control. Given the control measures which will be implemented during operations, and adequate training of operational staff in spill response measures, the impact to groundwater from the plant operations is assessed as *minor*.

Impact	Groundwater contamination				
Impact Nature	Negative	Positive		Neutral	
Impact Type	Direct	Indirect		Induced	
Impact Duration	Temporary	Short-term	Long-term	Permanent	
Impact Extent	Local	Regional		International	
Impact Scale	Project Footprint Area				
Likelihood	Unlikely				
Impact Magnitude	Positive	Negligible	Small	Medium	Large
Resource/ Receptor Sensitivity	Low		Medium	High	
Impact Significance	Negligible	Minor	Moderate	Major	
	Significance of impact is considered <b>minor</b> .				

Mitigation Measures

Other mitigation measures which will be adopted to reduce impacts on water quality to As Low as Reasonably Practicable are as follows:

- For minimising use of antifouling and corrosion inhibiting chemicals appropriate depth of water intake will be maintained and use of screens will be ensured;

- Minimum required quantities of chlorinated biocides or alternatively intermittent shot dosing of chlorine will be practised rather than continuous low level feed;
- Waste storage areas will be equipped with secondary containment and spill control measures (similar to the hazardous material storage areas) to limit impact to ground;
- Liquid wastes such as waste oil, etc. will be collected and stored for recycling in cemented areas; and
- All drainage/tanks, etc. will be positioned on concrete hard standing to prevent any seepage into ground.

### 6.4.3

#### *Air Quality*

##### Sources of Impact

The Project includes dual fuel fired combined cycle power plant (CCPP), consisting of 2 GT, 2 HRSG and 1 ST. The GT will be equipped with a set of dampers which will allow the turbine to operate in simple-cycle or combined-cycle mode. The bypass damper will control the flow through the bypass or simple-cycle stack, and the isolation damper will control flow through the HRSG. During start-up operations as well as during simple cycle operation, the isolation damper will be closed; preventing flue gas flow through the HRSG, and the bypass damper will be open, allowing flue gas to exit through the bypass stack. Once the turbine has completed start-up procedures the isolation damper will be opened and the bypass damper will be closed redirecting flue gas flow through the HRSG. The hot flue gas will heat boiler feed water to produce steam, which will be used to drive a steam turbine to produce more electricity in combined cycle operation. In the combined cycle operations, the flue gas will be allowed to exit through the main stack.

Two scenarios are considered for each fuel type (i.e. primary fuel – Natural Gas and secondary fuel – HSD). The scenarios considered are presented in Table 6.19.

**Table 6.19** *Modelling Scenarios for Air Quality Impact Assessment*

<b>Fuel</b>	<b>Scenario</b>	<b>Description</b>
Natural Gas (Primary Fuel)	1	Plant running in combined cycle (During normal operations after commission of combined cycle system)
HSD (Secondary Fuel)*	2	Plant running in combined cycle (During normal operations after commission of combined cycle system)

\* In order to consider worst case scenario, the plant availability has been considered as 80% time of the year.

The operation of the plant with natural gas as fuel in combined cycle will generate flue gas emissions containing NOx. Emissions of SO<sub>2</sub> are likely to be negligible, as natural gas typically has a no sulphur level (as per the natural gas specifications for the Project). Particulate emissions are likely to be negligible (about 1.7 mg/Nm<sup>3</sup>); as natural gas is a gaseous fuel (there is no supplementary fuel to be used in the GT). It is noted however that particulate

emissions (<1 µm diameter) in the form of un-burnt hydrocarbons and Volatile Organic Chemicals (VOCs) such as benzene and formaldehyde, may be released if poor air/fuel mixing and the incomplete combustion of the fuel source occurs. However, operation of the plant with HSD as fuel in combined cycle will generate flue gas emissions containing NO<sub>x</sub>, SO<sub>2</sub>, and PM.

Summary of Emission Sources and Emission Rates

The emission source during the operation of the Plant in combined cycle operation will be main stacks (attached to HRSG). Emissions from each stack based on the combined cycle operation along with stack parameters depending upon the fuel are presented in Table 6.20 and Table 6.21, respectively.

**Table 6.20 Emission Parameters for the Power Plant with Natural Gas as Fuel**

Stack	UTM Co-ordinates* (m)		Stack Height (m)*1	Stack Internal Diameter (m)	Flue Gas Exit Velocity (m/s)	Flue Gas Temperature (°K)	Volumetric Flow Rate (Nm <sup>3</sup> /s)	Emission Concentration**		Emission Rate	
	Easting	Northing						NOx	PM <sub>10</sub>	NOx	PM <sub>10</sub>
								mg/Nm <sup>3</sup>	mg/Nm <sup>3</sup>	(g/s)	(g/s)
Main Stack 1	264263	2487535	55	6	6	373	133	51	1.7	6.79	0.23
Main Stack 2	264305	2487552	55	6	6	373	133	51	1.7	6.79	0.23

\* UTM Zone - 46

\*\* Guaranteed emissions provided by the OEM for natural gas as fuel

Note: Stack parameters are as provided by NBBL. Stack height is calculated based on SO<sub>2</sub> emission load, which will be generated during plant operation with HSD.

**Table 6.21 Emission Parameters for the Power Plant with HSD as Fuel**

Stack						Emission Concentration*			Emission Rate		
	Stack Height (m)*2	Stack Internal Diameter (m)	Flue Gas Exit Velocity (m/s)	Flue Gas Temperature (°K)	Volumetric Flow Rate (Nm <sup>3</sup> /s)	NOx	SO <sub>2</sub>	PM <sub>10</sub>	NOx	SO <sub>2</sub>	PM <sub>10</sub>
						mg/Nm <sup>3</sup>	kg/hr	mg/Nm <sup>3</sup>	(g/s)	(g/s)	(g/s)
Main Stack 1	55	6	6	373	133	152	87	50	39	66	12.8
Main Stack 2	55	6	6	373	133	152	87	50	77	66	25.2

Note: Stack parameters are as provided by NBBL. Stack height is calculated based on SO<sub>2</sub> emission load, which will be generated during plant operation with HSD.

\* Guaranteed emissions of NOx and Particulate Matter provided by the OEM for liquid fuel.

<sup>1</sup> Stack height has been calculated based on average SO<sub>2</sub> emission rate of 87 kg/hr in case of use of HSD as fuel. In the updated design stack height of main stack is now considered as 60 m above the ground level and this will provide better dispersion conditions for the flue gas.

## Criteria

For the assessment of air quality, the sensitivity and magnitude criteria outlined in Table 6.11 and Table 6.22, respectively have been used. The standards considered for assessment of potential impacts to air quality, are *Schedule 11 ECR, 1997 of the GOB (Table 2.7)*,

**Table 6.22** *Criteria for Impact Magnitude for Assessment of Impact to Air Quality (Operation Phase)*

Magnitude Criteria	Negligible	Small	Medium	Large
Air Quality change in undegraded airshed (Baseline < applicable air quality standard (AQS))	<ul style="list-style-type: none"> <li>Project contribution &lt; 25% of AQS</li> </ul>	<ul style="list-style-type: none"> <li>Project contribution &gt; 25% of AQS but &lt; 50% of AQS; and Predicted environmental concentration &lt; 100% of AQS</li> </ul>	<ul style="list-style-type: none"> <li>Project contribution &gt; 25% of AQS but &lt; 50% of AQS; and Predicted environmental concentration &gt; 100% of AQS; or</li> <li>Project contribution &gt; 50% of AQS but &lt; 100% of AQS; and Predicted environmental concentration &lt; 100% of AQS;</li> </ul>	<ul style="list-style-type: none"> <li>Project contribution &gt; 50% of AQS; and Predicted environmental concentration &gt; 100% of AQS; or</li> <li>Project contribution &gt; 100% of AQS</li> </ul>
Air Quality change in degraded airshed (Baseline > AQS)	<ul style="list-style-type: none"> <li>Project contribution &lt; 10% of AQS</li> </ul>	<ul style="list-style-type: none"> <li>Project contribution &gt; 10% of AQS and &lt; 15% of AQS</li> </ul>	<ul style="list-style-type: none"> <li>Project contribution &gt; 15% of AQS and &lt; 25% of AQS</li> </ul>	<ul style="list-style-type: none"> <li>Project contribution &gt; 25% of AQS</li> </ul>

## Receptors

From the landuse analysis and field study, it is clear that most of the land surrounding the Project site is agricultural land and vegetation covered area. On the immediate east, there is existing power plant (225 MW Bhola I) followed by settlement, which is approximately 150 m from the proposed project site. The immediate south of the Project site has barren land followed by agricultural land. The immediate north site of the Project site has agricultural land followed by village (approximately 150 m from the Project site) and few dwellings within 100 m. The immediate west site of the Project site has Dehular Khal followed by agricultural land and settlement (approximately 400 m from the Project site). As can be referred from Table 6.11 and above discussion, the human receptors were assessed to be of Medium sensitivity, whereas ecological receptors were considered as of Low sensitivity.



### Prediction of Impacts

Impacts due to the operation of the plant were assessed by modelling projected emission rates (Table 6.20 and Table 6.21) using the AMS/EPA Regulatory Model (AERMOD). AERMOD is a modelling system consisting of three separate modules: AERMET, AERMAP and AERMOD. AERMET is a meteorological pre-processor and uses hourly surface observations, cloud cover, and upper air parameters from twice-daily vertical sampling of the atmosphere to create two output files consisting of surface and vertical profile data, respectively. The terrain pre-processor AERMAP uses DEM maps as well as user generated receptor grids. AERMAP's output file consists of the x, y locations of each receptor, mean sea level (MSL) elevation and hill profile parameters. The hill profile parameter is used in determining plume flow around elevated terrain.

**Model Options:** The AERMOD model was run with the following regulatory default options in this assessment:

- Stack-tip downwash;
- Elevated terrain effects;
- Use of calms processing routine;
- Use of missing data processing routine; and
- No exponential decay

The area surrounding the Project site has one operational 225 MW Bhola-I CCPP of BPDB and scattered rural settlements in the surroundings. Based on this, the Project site and its surroundings have been considered as rural area, and therefore, the rural dispersion coefficient was used in the Model.

**Meteorological Data:** The input meteorological data for the AERMOD was generated using the MM5 model, which was downscaled to fine grid data suitable for modelling. The data used in the study was site specific and was collected over one year period (2015). In all there were 8760 hours of meteorological data used in the model. This quantity of data allows an adequate assessment of hourly, 8-hourly, daily and annual average pollutant concentrations around the Project site.

**Terrain Data:** Terrain data for the AERMAP model were taken from the 30 m SRTM database, while land cover data was sourced from satellite imagery of the Project site and its surroundings.

**Receptors:** The receptor grid or network, defined the locations of predicted ground level concentrations (GLCs) used to assess compliance with the relevant standards or guidelines. The following comprehensive fine and coarse receptor network was used for this analysis:

- 100 m spaced receptors from the project boundary up to 10 km; and
- Cartesian receptors (5 nos.) located within the study area, where baseline monitoring was carried out during the study period.

This network used Cartesian (X, Y) receptors with UTM coordinates. Base elevation of all the receptors were found using terrain elevations interpolated from SRTM (~90 m) Digital Elevation Model (DEM) data. The discrete Cartesian receptor locations are shown in Figure 6.7 and details have been presented in Table 6.23.

**Table 6.23** *Monitoring Locations with respect to the Project*

S. No.	Name of monitoring location	UTM Co-ordinates* (m)			Distance from Plant Stacks (km)	Direction from Project Area
		Easting	Northing	Elevation		
1	AQ1	264806	2487799	11.0	0.60	E
2	AQ2	264313	2488197	5.0	0.65	N
3	AQ3	264026	2487038	5.0	0.57	SW
4	AQ4	263829	2487398	9.1	0.47	W
5	AQ5	264192	2488356	7.3	0.82	N

\* UTM Zone - 46

### Modelling Results

Predicted maximum ground level concentrations within the Project AOI with natural gas and HSD as fuel are presented in Table 6.24. While conducting the air dispersion modelling with HSD as fuel, it has been considered that the plant will run as peaking power plant with peak load factor of 80% only. Isopleths of ground level concentration for different averaging periods of the criteria pollutants (NO<sub>x</sub>, SO<sub>2</sub> and PM<sub>10</sub>) with natural gas and HSD as fuel are presented in Figure 6.8 to Figure 6.17.

It is evident from Table 6.24 that the maximum ground level concentration (maximum baseline concentration + predicted maximum concentration) in the Project AOI with natural gas as fuel will be well within the applicable standards for air quality in both the scenarios. Furthermore, using the determination of magnitude criteria (Table 6.22), it is evident that the project contribution for all the pollutants considered in the modelling study is < 25% of the applicable air quality standard. Therefore, the impact magnitude due to the operation of NBBL project using natural gas as fuel is assessed to be negligible.

On this basis, the potential air quality impacts due to the operation of the Plant by using natural gas as fuel are predicted to be *negligible*.

Impact	<i>Ambient Air Quality (by use of natural gas as fuel for power generation)</i>				
Impact Nature	Negative	Positive	Neutral		
Impact Type	Direct	Indirect	Induced		
Impact Duration	Temporary	Short-term	Long-term	Permanent	
Impact Extent	Local	Regional	International		
Impact Scale	Maximum impact zone within 2 km from project boundary in the downwind direction				
Impact Magnitude	Positive	Negligible	Small	Medium	Large
Resource/ Receptor Sensitivity	Low	Medium	High		

Impact Significance	Negligible	Minor	Moderate	Major
	Significance of impact is considered <b>negligible</b> .			

While using HSD as fuel, the maximum ground level concentrations (maximum baseline concentration + predicted maximum concentration) of NO<sub>x</sub>, SO<sub>2</sub> and PM<sub>10</sub> will also be within the applicable standard and overall project contribution will be < 25% of the applicable standard. Therefore, using the determination of magnitude criteria (Table 6.22), the impact magnitude due to the operation of NBBL project using HSD as fuel is assessed to be negligible. It shall be noted that the Project will be using natural gas as primary fuel and HSD will only be used in case of non-availability of natural gas from SGCL. Furthermore, in the event of a gas supply failure, the facility will not automatically switch to HSD as the decision rests with BPDB whether to operate the Plant on HSD or to pay capacity charges for the period of gas outage.

On this basis, the potential air quality impacts due to the operation of the Plant by using HSD as fuel are predicted to be *negligible*.

Impact	<i>Ambient Air Quality (by use of HSD as fuel for power generation)</i>				
Impact Nature	Negative	Positive	Neutral		
Impact Type	Direct	Indirect	Induced		
Impact Duration	Temporary	Short-term	Long-term	Permanent	
Impact Extent	Local	Regional	International		
Impact Scale	Maximum impact zone within 2 km from project boundary in the downwind direction				
Likelihood	Possible				
Impact Magnitude	Positive	Negligible	Small	Medium	Large
Resource/ Receptor Sensitivity	Low	Medium	High		
Impact Significance	Negligible	Minor	Moderate	Major	
	Significance of impact is considered <b>negligible</b> .				

Figure 6.7 Receptor Network and Emission Sources

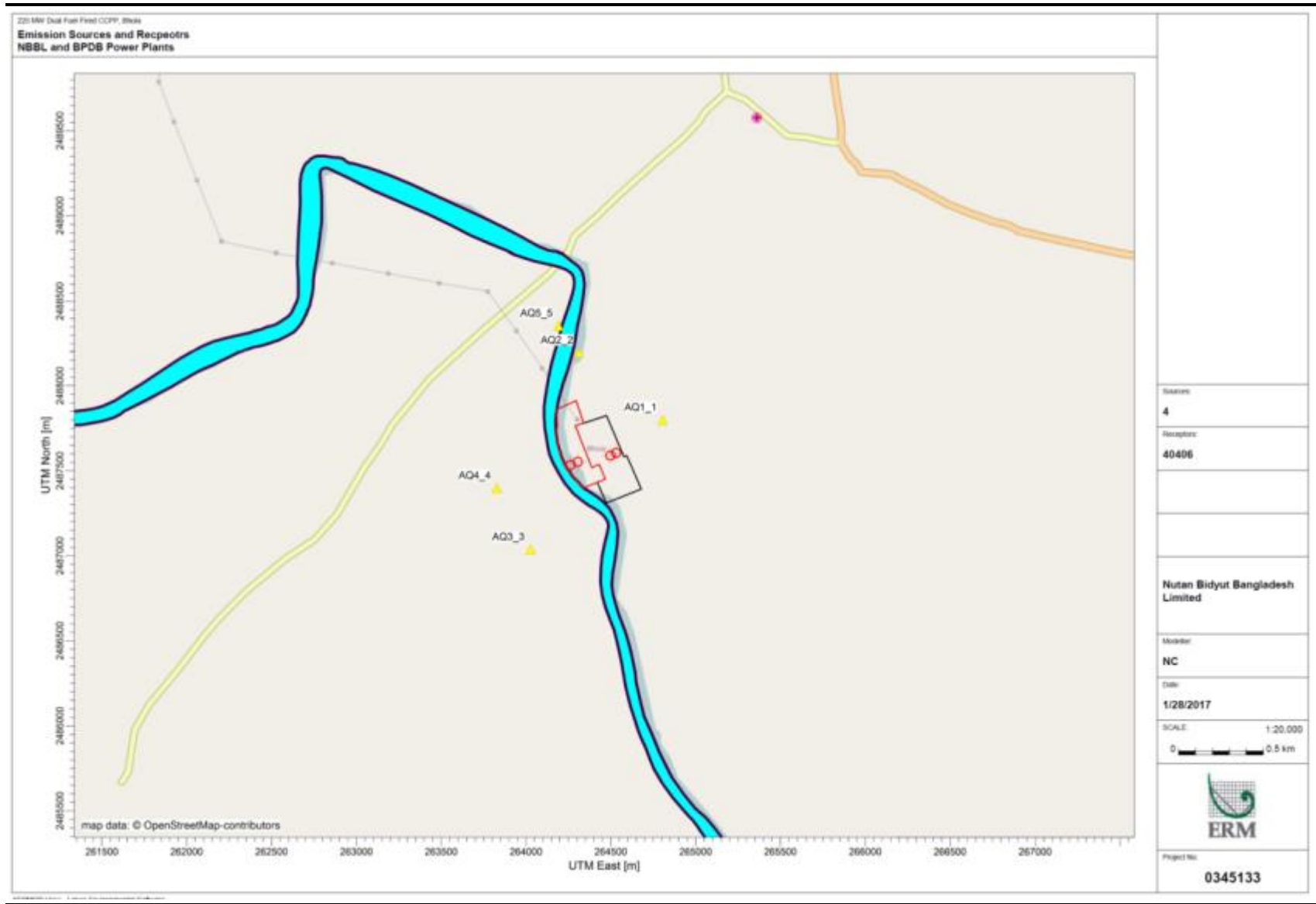


Table 6.24 Predicted Concentrations at Receptors due to Operation of NBBL with Gas and HSD as Fuel

Scenario	Pollutant	Average	Predicted Concentration (µg/m³)						Max. Background Concentration (µg/m³)*						Total Concentration (Predicted + Background) (µg/m³)					Bangladesh Standard (µg/m³)	WB Standard (µg/m³)
			Max	AQ 1	AQ 2	AQ 3	AQ 4	AQ 5	Max	AQ 1	AQ 2	AQ 3	AQ 4	AQ 5	Max	AQ 1	AQ 2	AQ 3	AQ 4		
NBBL Operation with Natural Gas as Fuel	NO <sub>x</sub>	1-hourly	27.0	22.1	21.8	21.6	17.1	17.9	70.6	68.5	59.6	70.7	50.0	61.1	97.6	90.6	81.4	92.2	67.2	-	200
		24-hourly	8.4	5.8	8.3	5.0	4.3	5.9	29.0	28.1	24.5	29.0	20.6	25.1	37.4	33.9	32.7	34.0	24.8	-	-
		Annual	2.0	0.6	1.9	0.7	0.6	1.6	5.6	5.4	4.7	5.6	3.9	4.8	7.6	5.9	6.6	6.2	4.5	100	40
	PM10	24-hourly	0.28	0.19	0.28	0.17	0.14	0.20	42.4	38.2	34.8	41.5	31.5	42.4	42.6	38.4	35.1	41.7	31.6	150	100
		Annual	0.07	0.02	0.06	0.02	0.02	0.05	8.1	7.3	6.7	8.0	6.0	8.1	8.2	7.3	6.7	8.0	6.1	50	50
NBBL Operation with HSD as Fuel	NO <sub>x</sub>	1-hourly	80.5	65.9	65.0	64.3	51.1	53.3	70.6	68.5	59.6	70.7	50.0	61.1	151.1	134.4	124.6	134.9	101.1	---	200
		24-hourly	25.0	17.2	24.6	14.9	12.7	17.5	29.0	28.1	24.5	29.0	20.6	25.1	54.0	45.3	49.1	43.9	33.3	---	---
		Annual	5.9	1.7	5.6	2.0	1.7	4.7	5.6	5.4	4.7	5.6	3.9	4.8	11.5	7.1	10.3	7.6	5.7	100	40
	SO <sub>2</sub>	24-hourly	29.9	20.5	29.4	17.8	15.2	20.9	16.9	16.3	13.7	16.9	12.6	16.4	46.8	36.8	43.1	34.7	27.8	365	50
		Annual	7.1	2.0	6.7	2.4	2.1	5.6	3.2	3.1	2.6	3.2	2.4	3.1	10.3	5.1	9.4	5.7	4.5	80	---
PM10	24-hourly	8.2	5.6	8.1	4.9	4.2	5.8	42.4	38.2	34.8	41.5	31.5	42.4	50.6	43.9	42.9	46.4	35.7	150	100	
	Annual	2.0	0.5	1.9	0.7	0.6	1.5	8.1	7.3	6.7	8.0	6.0	8.1	10.1	7.9	8.5	8.6	6.6	50	50	

\* Refer to Table 4.15. Highlighted cells indicate calculated background concentrations.

Monitoring was carried out for 1 month with 24 hourly averages. Therefore, in order to provide 1-hourly maximum and annual average concentrations, conversions are done using the power law relationship given below:

$$C_{long} = C_{short}(t_{short}/t_{long})^p$$

where:

$C_{long}$  = the concentration for the longer averaging time

$C_{short}$  = the concentration for the shorter averaging time

$T_{short}$  = the shorter averaging time (in minutes)

$T_{long}$  = the longer averaging time (in minutes)

$p$  = the power law exponent

For ambient air assessments a  $p$  value of 0.28 is used. This methodology is deemed to give conservative estimates and thus is deemed appropriate for this case.

Figure 6.8 NOx Isopleths - 1 Hourly Maximum Ground Level Concentrations (NBBL Operation with Natural Gas as Fuel)

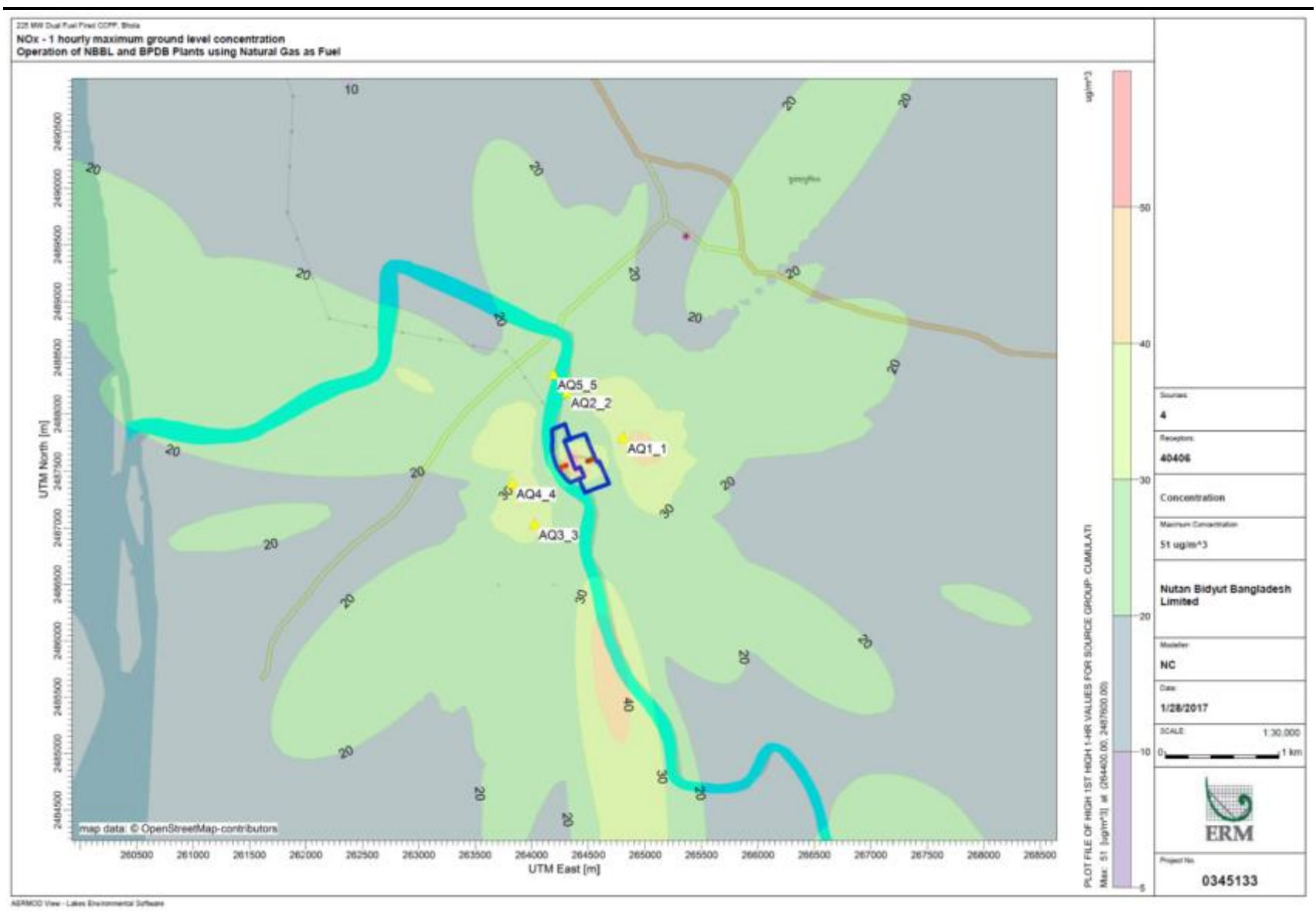


Figure 6.9 NOx Isopleths - 1 Hourly Maximum Ground Level Concentrations (NBBL Operation with HSD as Fuel)

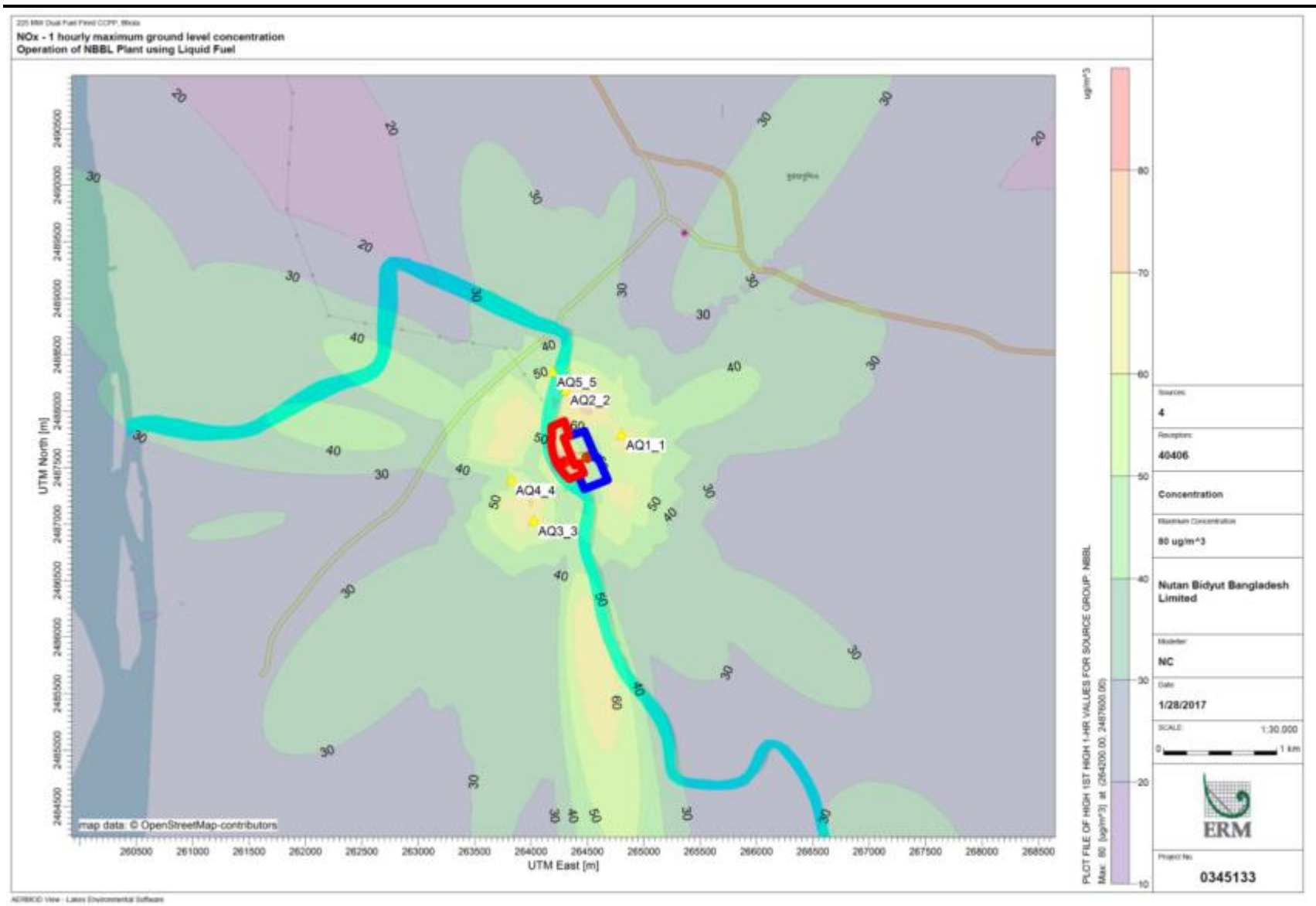




Figure 6.10 NOx Isopleths - 24 Hourly Maximum Ground Level Concentrations (NBBL Operation with Natural Gas as Fuel)

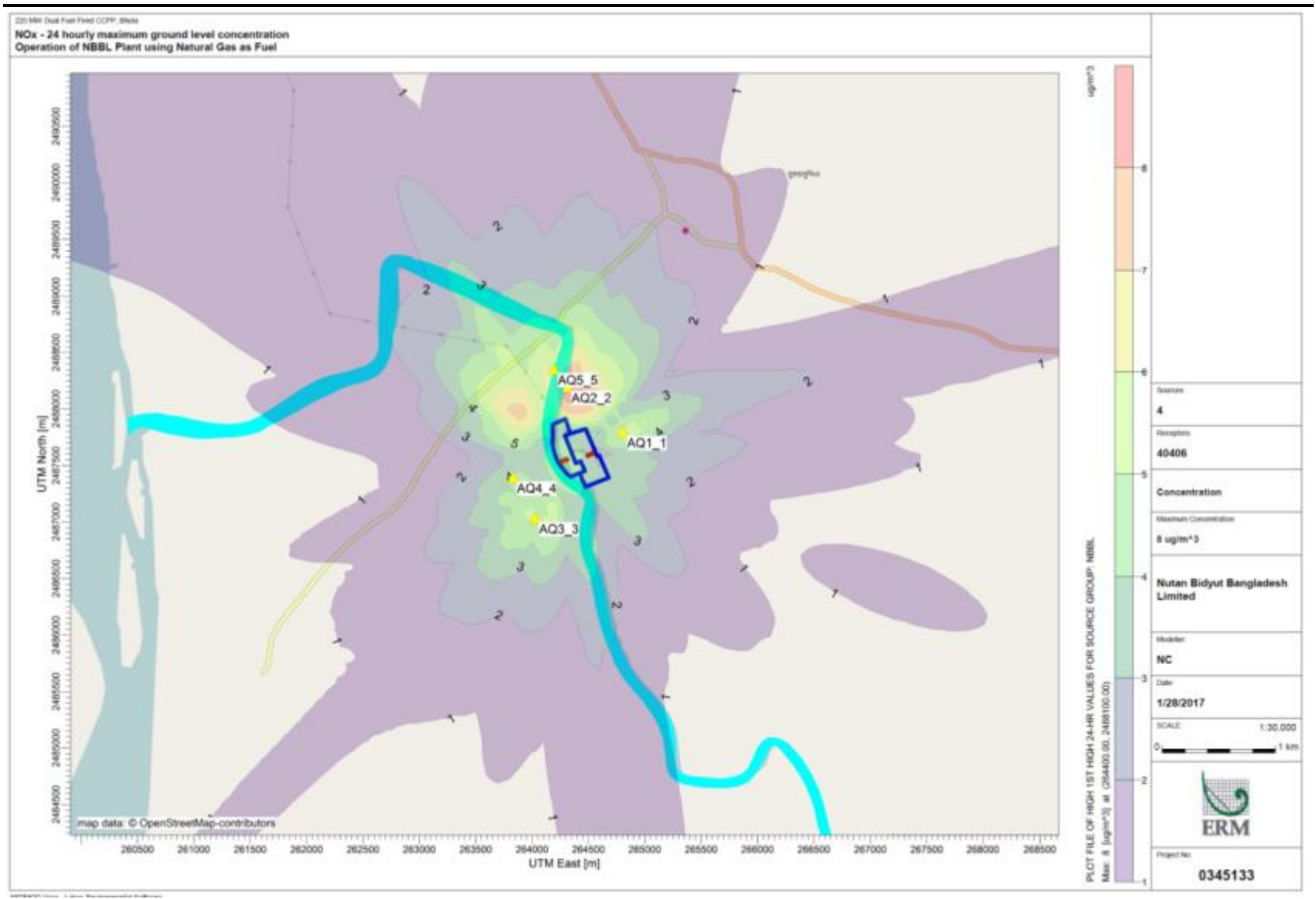


Figure 6.11 NOx Isopleths - 24 Hourly Maximum Ground Level Concentrations (NBBL Operation with HSD as Fuel)

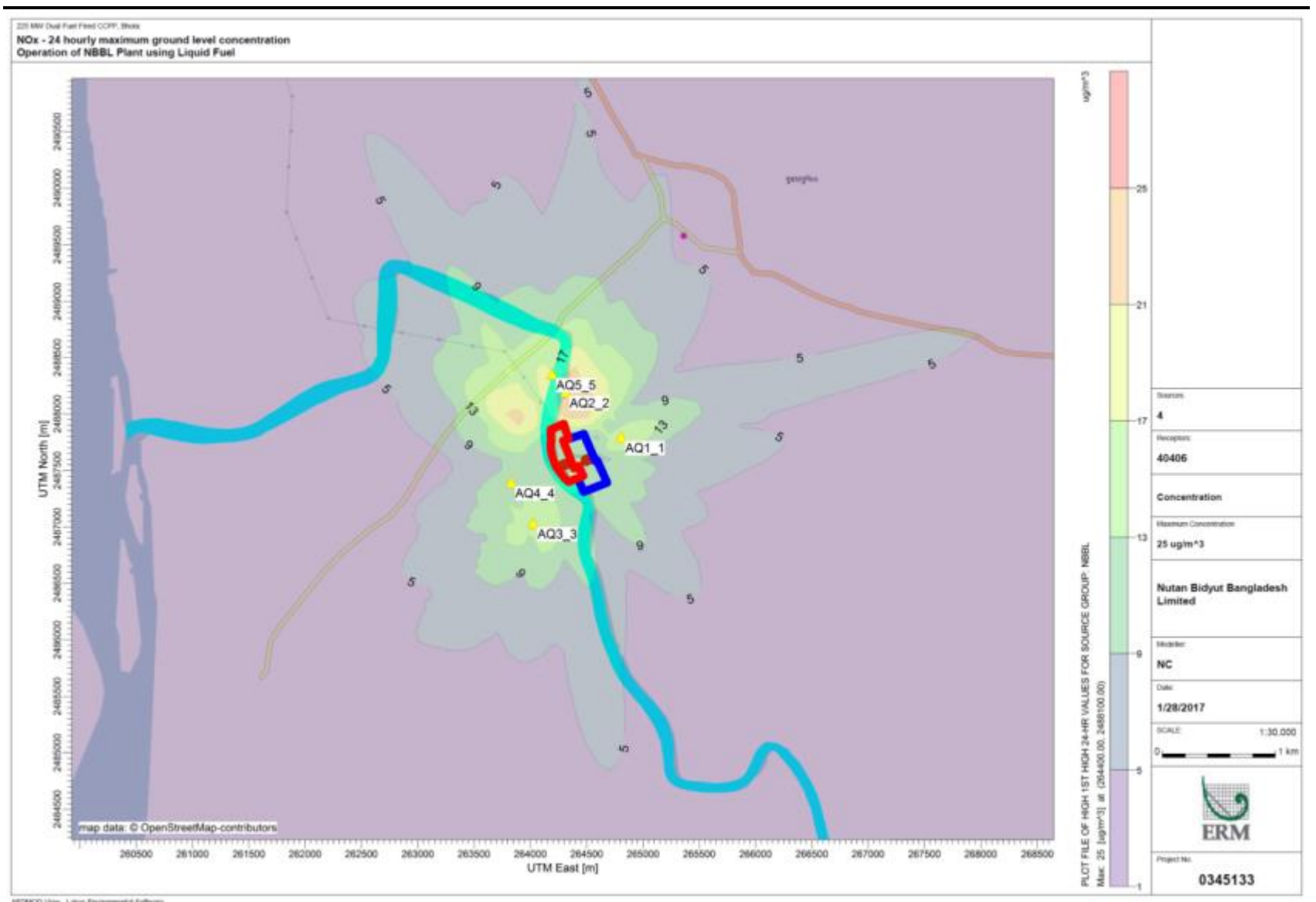




Figure 6.12 NOx Isopleths – Annual Average Ground Level Concentrations (NBBL Operation with Natural Gas as Fuel)

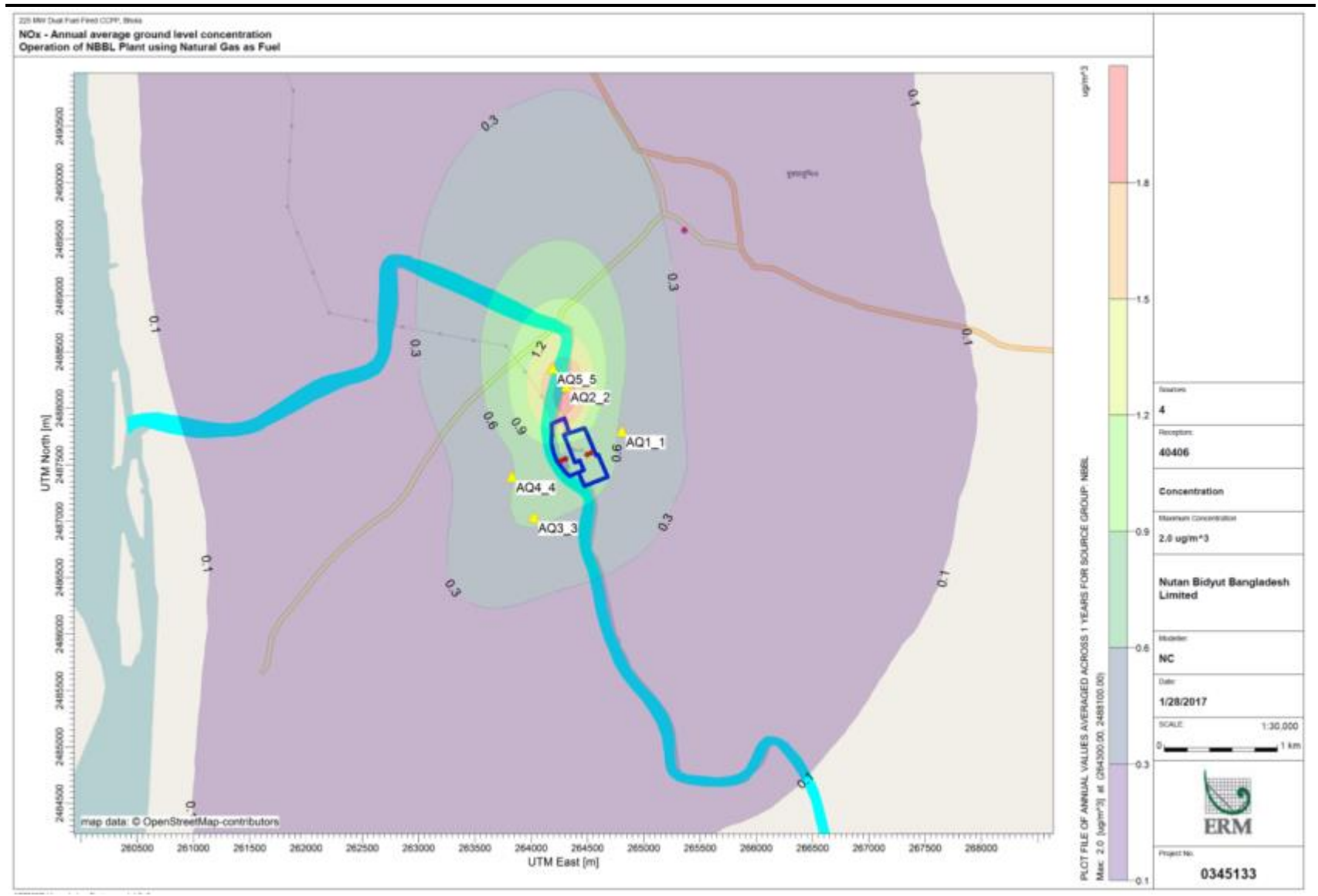


Figure 6.13 NOx Isopleths – Annual Average Ground Level Concentrations (NBBL Operation with HSD as Fuel)

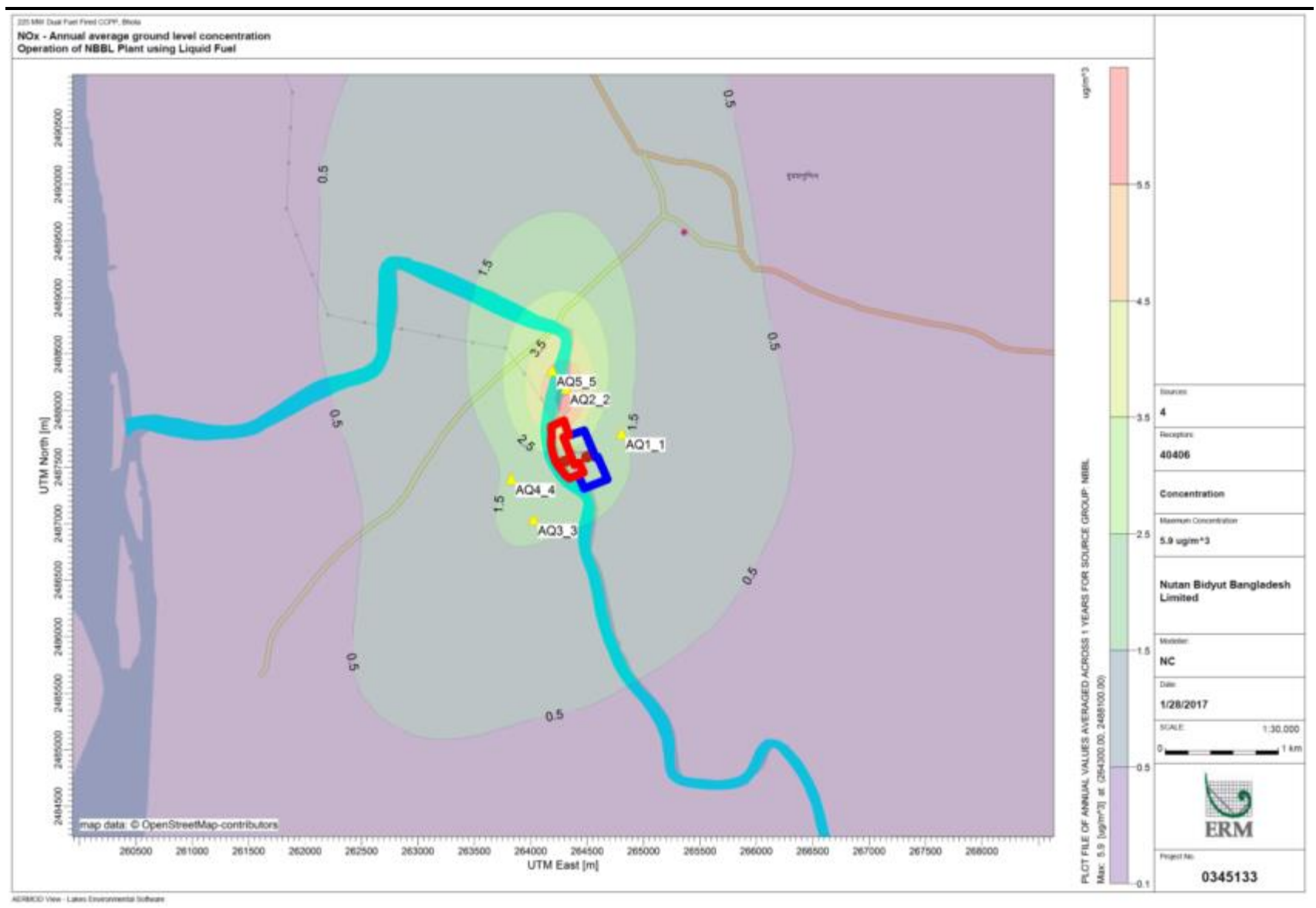


Figure 6.14 SO<sub>2</sub> Isopleths - 24 Hourly Maximum Ground Level Concentrations (NBBL Operation with HSD as Fuel)

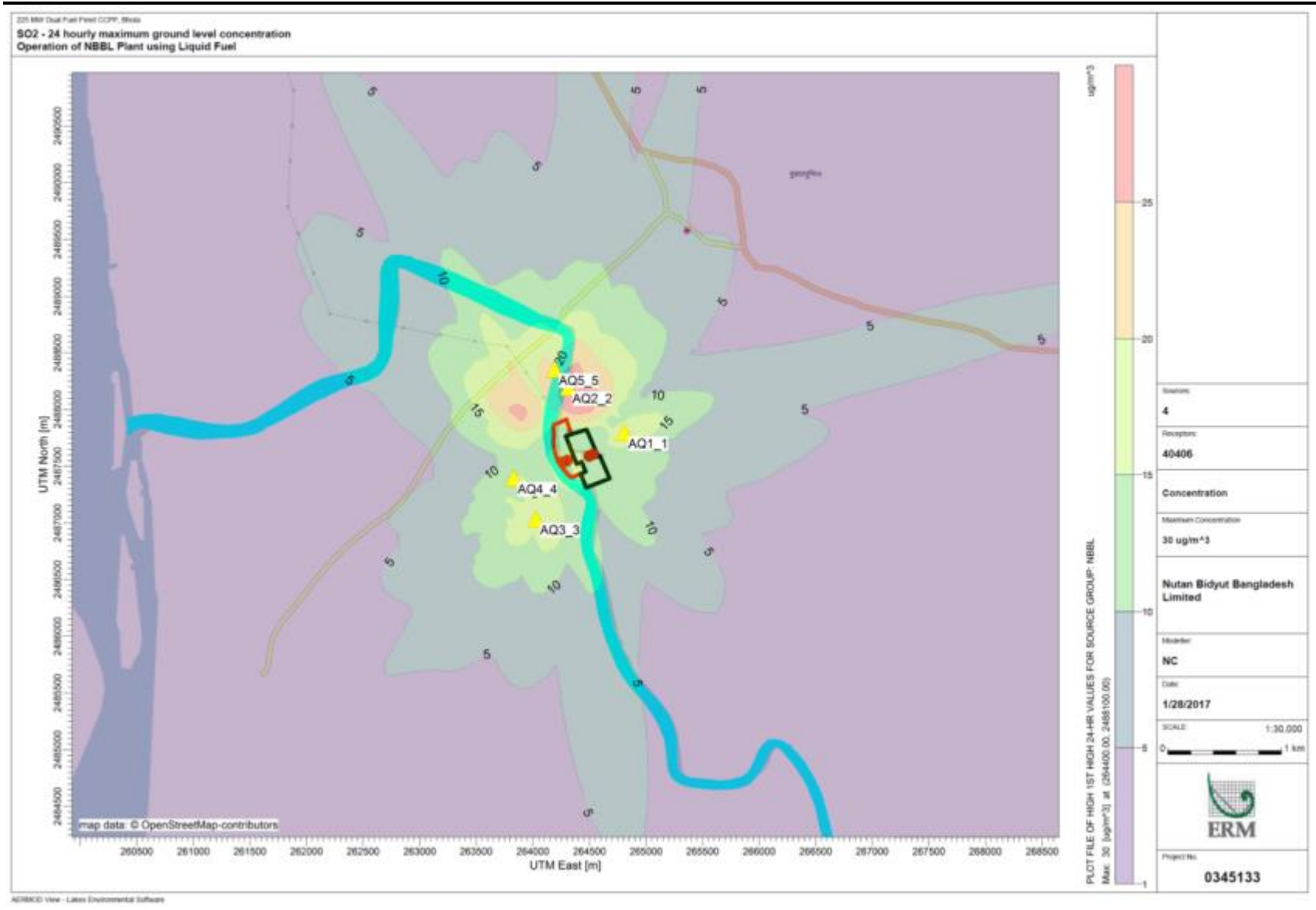


Figure 6.15 SO<sub>2</sub> Isopleths - Annual Average Ground Level Concentrations (NBBL Operation with HSD as Fuel)

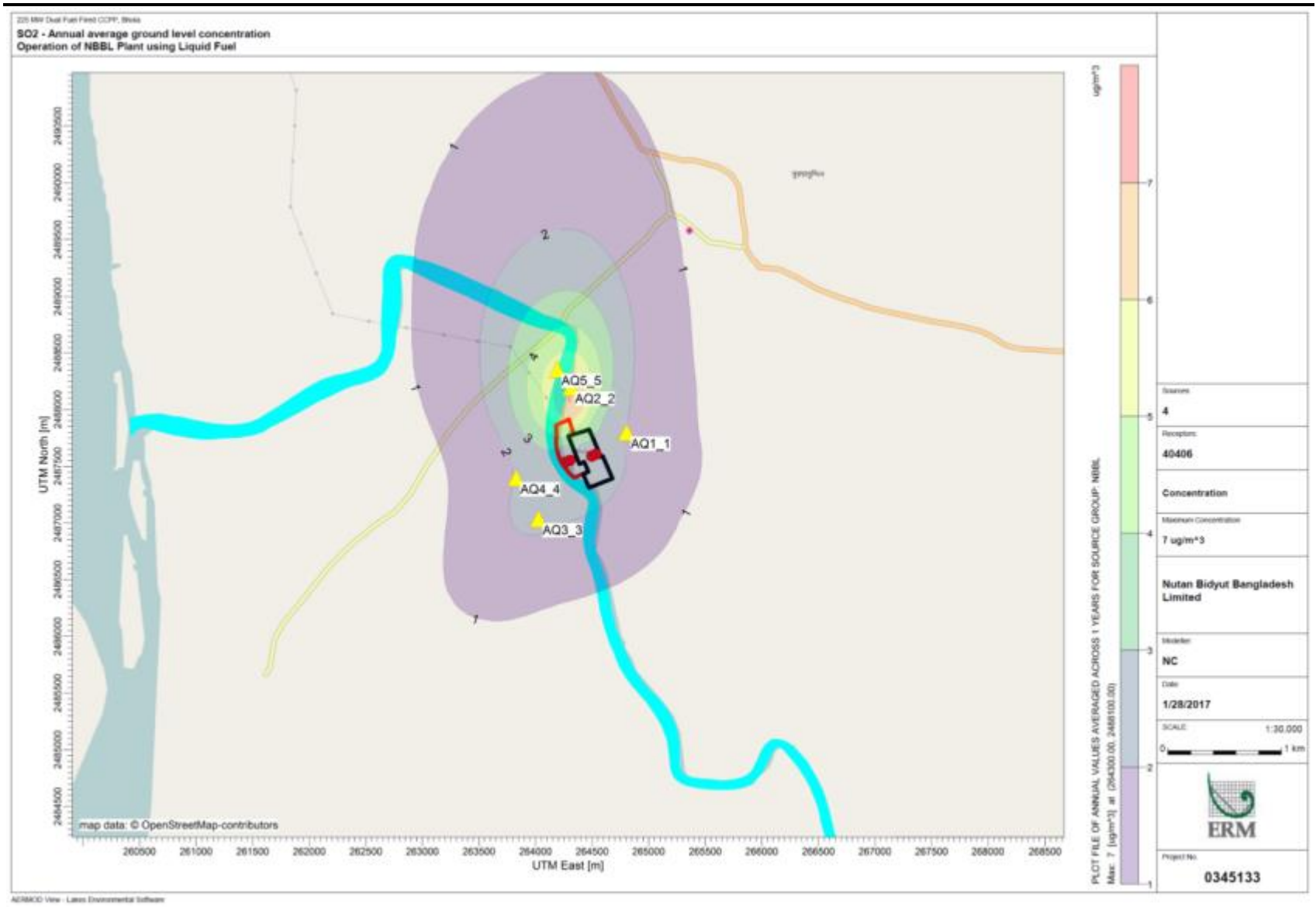




Figure 6.16 *PM<sub>10</sub> Isopleths – 24 hourly Maximum Ground Level Concentrations (NBBL Operation with HSD as Fuel)*

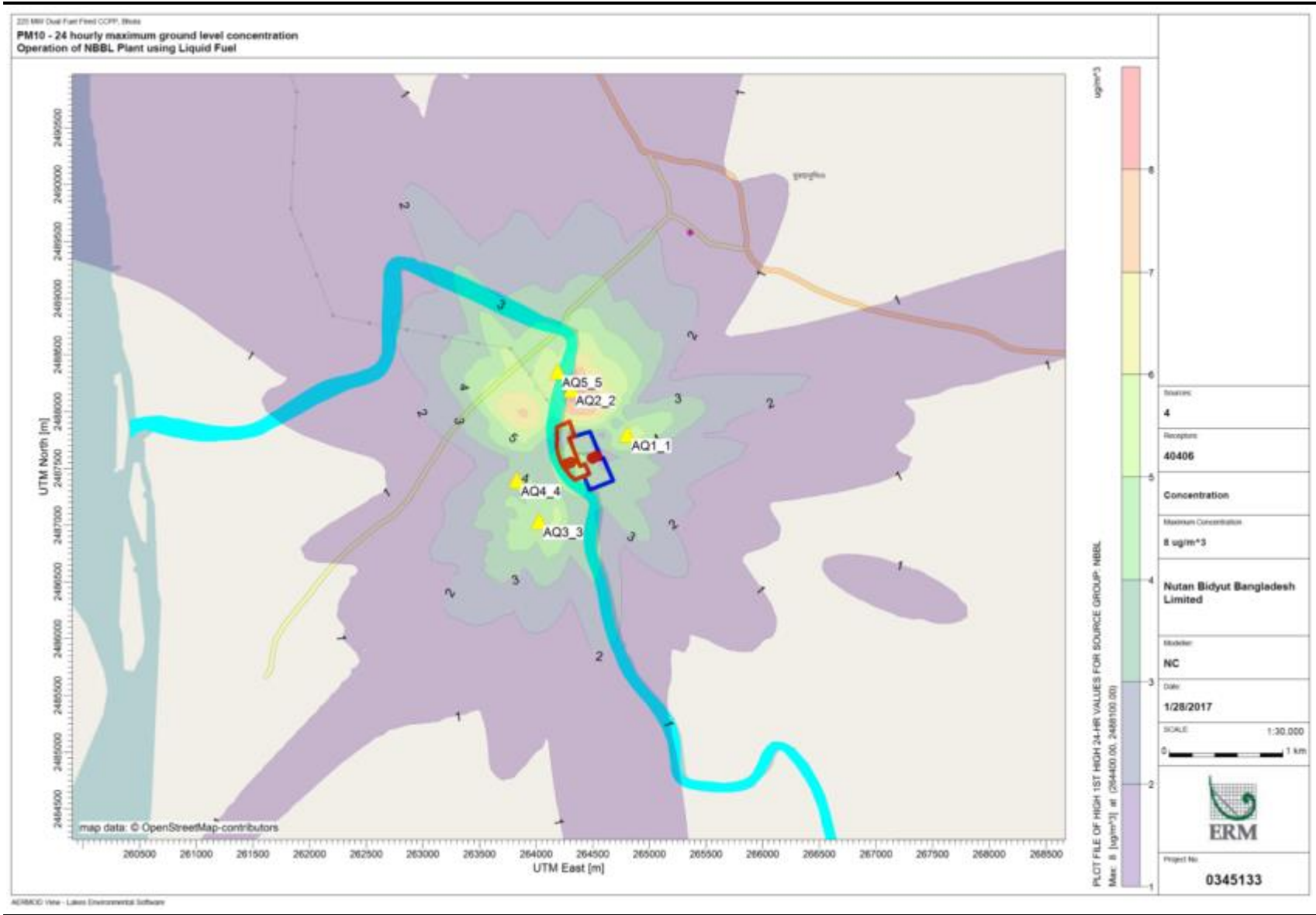
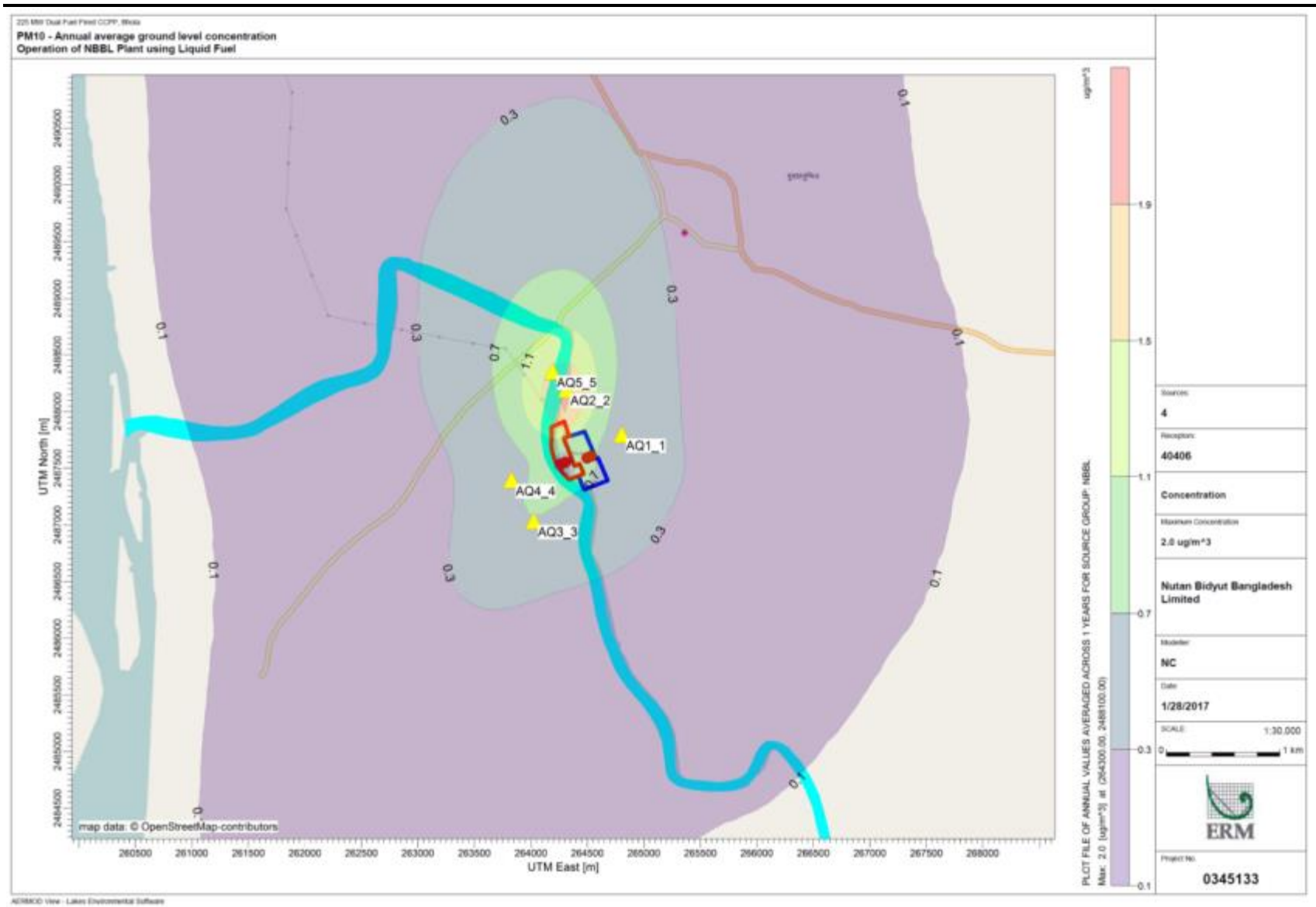


Figure 6.17 *PM<sub>10</sub> Isopleths – Annual Average Ground Level Concentrations (NBBL Operation with HSD as Fuel)*



### Mitigation Measures

To ensure compliance with the air emission criteria for flue gas stacks, the following measures will be implemented during operations:

- The use of continuous emission monitoring (CEM) equipment for the measurement of air emission levels in the exhaust stack of HRSG. CEM will be undertaken for NO<sub>x</sub>, SO<sub>2</sub>, CO and O<sub>2</sub>;
- PM<sub>2.5</sub> and VOCs will be monitored periodically, to ensure that these emissions are not occurring as a result of the incomplete burning of the natural gas fuel and use of HSD as fuel.
- The stack will be provided with safe access to sampling points for CEM.
- HSD shall be used only during shortage of natural gas supply.

#### 6.4.4 *Green House Gas Emissions*

The Kyoto Protocol – United Nations Framework Convention on Climate Change nominates the following GHGs:

- Carbon dioxide (CO<sub>2</sub>);
- Methane (CH<sub>4</sub>);
- Nitrous Oxide (N<sub>2</sub>O);
- Hydrofluorocarbons (HFCs); and
- Perfluorocarbons (PFCs).

Inventories of GHG emissions can be calculated using published emission factors. Different gases have different greenhouse warming effects (referred to as warming potentials) and emission factors take into account the global warming potentials of the gases created during combustion.

Typically, greenhouse gas emissions are reported in units of carbon dioxide equivalent (CO<sub>2</sub>e). Gases are converted to CO<sub>2</sub>e by multiplying by the gas' global warming potential (GWP). The GWP of gases are as follows<sup>1</sup>:

- GWP for CO<sub>2</sub> = 1
- GWP for CH<sub>4</sub> = 21
- GWP for N<sub>2</sub>O = 310

When the global warming potentials are applied to the estimated emissions then the resulting estimate is referred in terms of CO<sub>2</sub>-equivalent (CO<sub>2</sub>e) emissions.

#### *Operation of NBBL Project*

#### GHG Estimation and Impact

The combustion of natural gas produces GHGs. The amount of GHGs emitted by a power plant is a measure of its contribution to global warming and can be estimated based on fuel consumption. In order to estimate GHG emissions,

(1) <sup>1</sup> Source: Intergovernmental Panel on Climate Change (IPCC) (1995), Second Assessment Report

the IFC recommended Carbon Emission Estimation Tool (CEET model – Version February 2014)<sup>1</sup> has been used as set out below.

**Table 6.25 Estimated GHG Emissions from the Plant**

SN	Particular	Value	Unit
<b>Using Natural Gas as Fuel</b>			
A*	Net Heat Rate (Natural Gas in Combined Cycle)	7,278	KJ/KWH
B*	Gross Generation Capacity (Combined Cycle)	225,000	KW
C	Operating Days	330	days
D	Daily Operating Hours	24	Hours/day
E	Total Annual Output (= B x C x D)	1,782,000,000	KWH
F	Annual Fuel Consumption (= E x A)	1.29694E+13	KJ
		12,969.40	TJ
G*	GHG Emission Rates		
	CO <sub>2</sub>	56.1	tCO <sub>2</sub> /TJ
	CH <sub>4</sub>	0.001	tCO <sub>2</sub> /TJ
	N <sub>2</sub> O	0.003	tCO <sub>2</sub> /TJ
<b>H</b>	<b>Annual GHG Emission in Combined Cycle</b>	<b>739,917</b>	<b>tCO<sub>2</sub>e/year</b>
<b>Using HSD as Fuel</b>			
A*	Net Heat Rate (HSD in Combined Cycle)	6,841	KJ/KWH
B*	Gross Generation Capacity (Combined Cycle)	225,000	KW
C	Operating Days	330	days
D	Daily Operating Hours	24	Hours/day
E	Total Annual Output (= B x C x D)	1,782,000,000	KWH
F	Annual Fuel Consumption (= E x A)	1.22E+13	KJ
		12,190.66	TJ
G*	GHG Emission Rates		
	CO <sub>2</sub>	74.1	tCO <sub>2</sub> /TJ
	CH <sub>4</sub>	0.003	tCO <sub>2</sub> /TJ
	N <sub>2</sub> O	0.018	tCO <sub>2</sub> /TJ
<b>H</b>	<b>Annual GHG Emission in Combined Cycle</b>	<b>903,584</b>	<b>tCO<sub>2</sub>e/year</b>

\* Based on natural gas specification provided by NBBL (refer to Table 3.1 for details).

\*\* Based on GHG emission factors provided in CEET

It is evident from **Table 6.25** that the estimated GHG emissions from the Plant while using natural gas as primary fuel will exceed the threshold of ADB SPS (100,000 tons CO<sub>2</sub>e per year) and of IFC PS3 (25,000 tons CO<sub>2</sub>e per year) that define them as significant GHG emission sources. Therefore, the Project is required to report annual GHG emissions.

As per the latest report (26 December 2012) of GHG emission submitted by Bangladesh to the United Nations Framework Convention on Climate Change (UNFCCC)<sup>2</sup>, electricity generation sector contribution to GHG emission in year 2005 was 1.192 x 10<sup>7</sup> tons CO<sub>2</sub>e and projection of aggregate GHG emissions using LEAP modelling program indicates that the annual GHG emissions from this sector in year 2020 and 2030 will be 2.752 x 10<sup>7</sup> tons CO<sub>2</sub>e

<sup>1</sup>

[http://www.ifc.org/wps/wcm/connect/Topics\\_Ext\\_Content/IFC\\_External\\_Corporate\\_Site/CB\\_Home/Measuring+Reporting/](http://www.ifc.org/wps/wcm/connect/Topics_Ext_Content/IFC_External_Corporate_Site/CB_Home/Measuring+Reporting/)

<sup>2</sup> <http://unfccc.int/resource/docs/natc/bgdnc2.pdf>

and  $5.9168 \times 10^7$  tons CO<sub>2</sub>e, respectively. Taking this into consideration, GHG emission contribution of the proposed Project in the year 2020 will be between 2.53% to 2.69% of the electricity generation sector in Bangladesh, depending upon the fuel use for power generation. Considering this fact, the GHG emission impact will be **moderate**.

Impact	<i>GHG emissions from operation of NBBL project</i>				
Impact Nature	Negative	Positive	Neutral		
Impact Type	Direct	Indirect		Induced	
Impact Duration	Temporary	Short-term	Long-term	Permanent	
Impact Extent	Local	Regional		National	
Impact Scale	Impact zone will be regional/ national				
Frequency	Operation Phase				
Impact Magnitude	Positive	Negligible	Small	Medium	Large
Impact Significance	Negligible	Minor	Moderate	Major	
	Significance of impact is considered <b>moderate</b> .				

#### Mitigation Measures

The following mitigation measures will minimise GHG emissions to ALARP levels:

- Consituous monitoring and recording of CO<sub>2</sub> emission from the stacks through CEMS.
- Ensure that all equipment and machinery is maintained in accordance with manufacturer's specifications;
- Higher efficiency steam turbine blade design; and
- Improved efficiency of auxiliary drives.

#### 6.4.5

#### *Noise*

##### *Operation of NBBL Project*

##### Sources of Impact

For gas/ oil-fired power plants, the major noise sources during base load operation are the air-cooled condenser (ACC) or cooling tower, steam turbine generator (STG), combustion inlet filter house, and the exhaust stack or heat recovery steam generator (HRSG). During start-up or other transient conditions in combined cycle configurations, the high-pressure steam piping and condenser is a major noise producer, with steam bypassing the STG. The combustion turbine and generator (CTG) are typically housed in acoustical enclosures, thereby dropping their respective noise source ranking. Other balance-of-plant (BOP) equipment also generates noise. The cumulative effects of fuel gas compressors, air compressor skids, boiler feed water pumps, lube oil coolers, and other equipment may affect far-field noise levels.

Noise and vibration from the Project will be mitigated through engineering control and wherever possible high noise equipment will be enclosed in noise-

proofed buildings that effectively contain the noise. The engineering noise control measures with respect to key project components are specified below:

**Combustion Turbine:** High noise levels originate in the air inlet and flue gas exhaust. Strong pure tonal components are associated with the inlet while the exhaust results in high levels of low frequency noise. Specially designed silencers are provided to control such noise emissions to acceptable levels.

**HRSG:** Venting of steam will occur during HRSG start up and blowdowns. This is routinely controlled by suitable silencers. Boiler safety valves are tested on an annual basis. Outside of such testing, operation of safety valves will occur for very short periods under fault conditions. They will be fitted with silencers but will be audible outside the plant. Owing to their safety function it is not possible to totally abate noise from such high temperature/high volume sources.

**Steam Turbine:** The steam turbine, together with a range of auxiliary plant, much of which contains rotating or reciprocating machines, is a source of noise. This is attenuated by acoustic lagging and enclosure and by the acoustic design of the turbine house.

**Gas Release:** When it is required to purge the gas pipelines and gas compressor, gas will be vented to the atmosphere. This will last for a short period and may result in slightly increased noise levels.

**Transformers:** Fans on generator and other large transformers are provided for cooling purposes. The transformers themselves may emit noise at multiples of the power line frequency (50 Hz) but are treated to minimise noise emission and will be inaudible at the site boundary.

**Substation and Transmission Lines:** Transmission lines can also generate a small amount of sound energy (a crackling or humming sound) as a result of corona<sup>1</sup>. It becomes more noticeable at higher voltages (345 kV and higher). As the existing transmission line is of 230 kV, no corona is heard in vicinity of the transmission line.

### Criteria

It is planned that the Project will meet the noise emission criteria specified in the GOB ECR, 1997 and the WB/IFC EHS Guidelines, as presented in Table 2.11. Furthermore, for the assessment of ambient noise, the sensitivity and magnitude criteria outlined in Table 6.14 and Table 6.15, respectively have been used:

<sup>1</sup> Corona is the partial electrical breakdown of the insulating properties of air around the conductors of a transmission line. In a small volume near the surface of the conductors, energy and heat are dissipated. Part of this energy is in the form of small local pressure changes that result in audible noise.



**Table 6.26 Noise Emission Criteria**

Location	Noise Level Limit (dB(A))	
	Daytime (0600 - 2100 hrs)	Night-time (2100 - 0600 hrs)
Equipment (1m from source)	85	85
Plant Boundary	70	70
Nearest Residential Area	55	45

Receptors

Baseline noise monitoring was carried out at nine locations. The results of baseline monitoring indicated that ambient noise levels at residential areas were high compared to the applicable standards. The nearest receptor is located at 60 m from the Project boundary, which will be exposed to noise from construction activities. Apart from this the settlements located close to the access road will also be affected due to the movement of vehicles.

As can be referred from Table 6.14 and above discussion, the receptors as well as the ecological receptors were assessed to be of Low sensitivity, whereas the human settlements in the surrounding areas (residential areas) were assessed to be of Medium sensitivity.

Prediction of Impacts

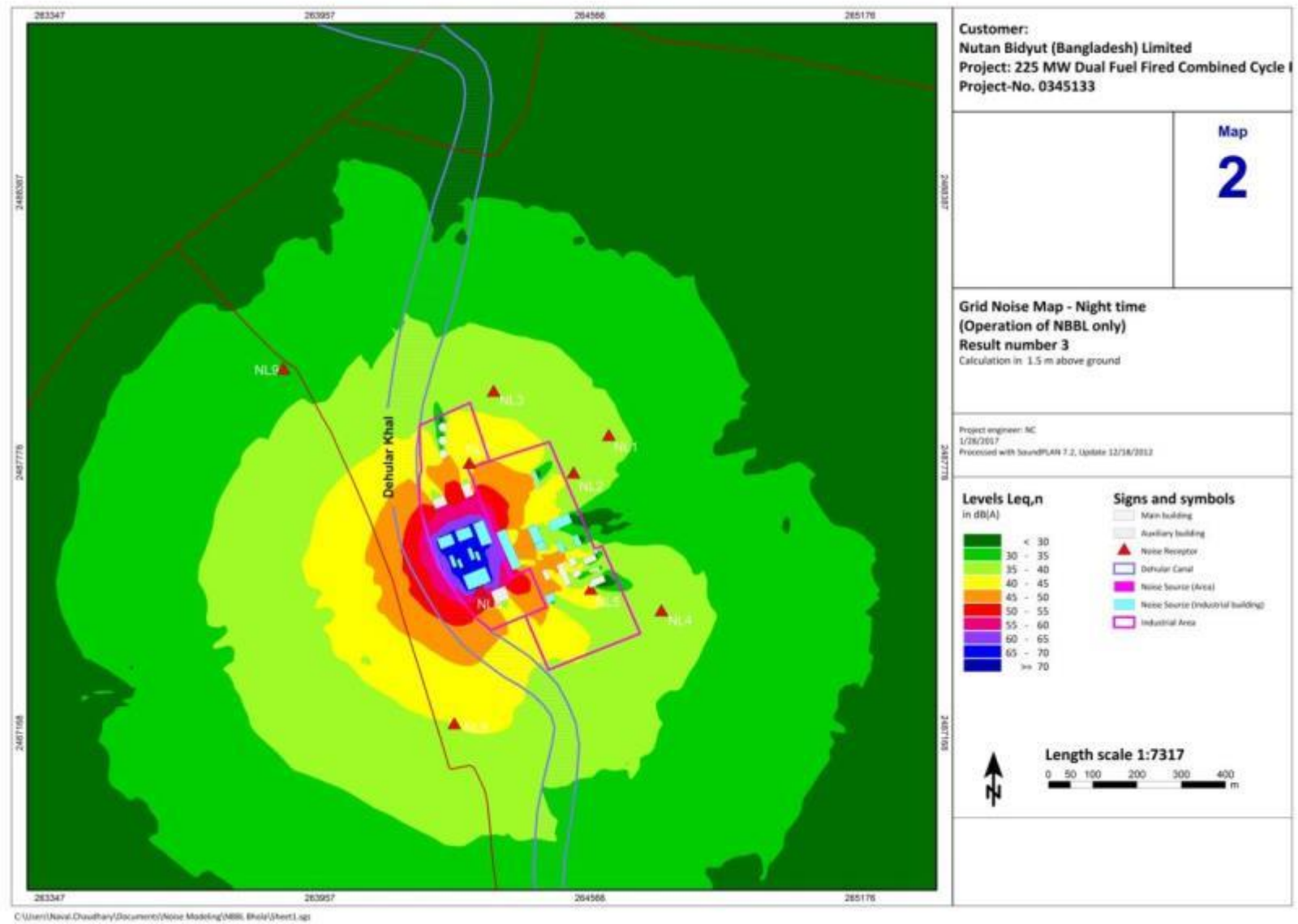
**Methodology:** The environmental noise prediction model SoundPLAN 7.2 was used for modelling noise emissions from the use of power plant equipment and vehicular movement in the access road. It has been assumed that all the plant equipment will adhere to the equipment noise emission criteria of 85 dB(A) noise level at a distance of 1 m from the source. Operation of equipment with 100% usage scenario was modelled to cover the operation phase of the Project. Major plant components with higher noise generation considered in this study include GTG, STG, HRSG, Auxiliary Boiler, Cooling Tower, CW Pump House, Emergency DG, Water Treatment Facility, Pump House, RMS, and Gas Booster and Conditioning Station. As a conservative approach to the assessment, atmospheric absorption during sound transmission was not included in the assessment. In addition, to represent a worst-case scenario for the assessment, all equipment was assumed to be operating simultaneously. Attenuation due to already constructed boundary and existing Bhola I CCPP buildings and structures has been considered in the modelling.

**Predicted Noise Levels at Receptors:** The predicted noise levels within the Project AOI during day time are presented in Figure 6.19. Predicted noise levels at nine receptors (where baseline noise levels were also monitored, which include four receptors within or just outside the boundary of the power complex) have been presented in Table 6.27.

Figure 6.18 Noise Sources and Receptors Location in Topographic Map



Figure 6.19 Predicted Operation Phase Noise Levels of NBBL Project during Daytime ( $Leq_{day}$ )



**Table 6.27 Predicted Noise Levels at Noise Receptors during Operation Phase of NBBL Project**

Receptor Code	Approximate Distance to Power complex Boundary (m) and Direction from Project Site	Baseline Sound Pressure Levels at Receptors, Leq (dBA) <sup>(1)</sup>		Predicted Sound Pressure Levels at Receptors, Leq (dBA)		Total Sound Pressure Level (Baseline + Predicted), Leq (dBA)		Applicable Standard (dB(A)) <sup>(2)</sup> <sup>(3)</sup> as per Landuse	
		Leq <sub>d</sub> *	Leq <sub>n</sub> *	Leq <sub>d</sub>	Leq <sub>n</sub>	Leq <sub>d</sub>	Leq <sub>n</sub>	Leq <sub>d</sub>	Leq <sub>n</sub>
NL1	130 (E)	53.5	51.0	35.6	35.6	53.6	51.1	55	45
NL2	Complex boundary	65.4	66.1	38.6	38.6	65.4	66.1	70	70
NL3	10 (N)	62.1	54.4	38.2	38.2	62.1	54.5	55	45
NL4	60 (E)	58.3	53.0	36.7	36.7	58.3	53.1	55	45
NL5	within complex	56.9	53.0	39.6	39.6	57.0	53.2	70	70
NL6	within complex	46.3	46.0	59.3	59.3	59.5	59.5	70	70
NL7	within complex	64.8	63.2	42.9	42.9	64.8	63.2	70	70
NL8	230 (SW)	56.8	49.0	39.9	39.9	56.9	49.5	55	45
NL9	340 (NW)	53.9	49.4	33.2	33.2	53.9	49.5	55	45

<sup>(1)</sup> Ambient noise levels as monitored during the baseline survey

<sup>(2)</sup> Environmental Conservation Rules, 1997 (Schedule 4) amended September 7, 2006

<sup>(3)</sup> IFC/WB EHS Guidelines: Noise Management dated April 30, 2007 gives, Noise level guidelines for Residential; institutional and educational receptors in daytime (07:22:00) and night time (22:00-7:00) as 55 and 45 one hour Leq dBA respectively. For industrial and commercial receptors it is 70 one hour Leq dBA for both night and day time.

<sup>(4)</sup> All operations have been considered as continuous and hence there is no change in the day and night time prediction results.

It is evident from Table 6.27 that ambient noise levels due to operation of NBBL project will be well within the applicable standard during day time at 6 receptors and night time at 4 receptors, out of total 9 receptors considered in the study. All the exceedances are due to already higher baseline noise levels during day and night time, whereas predicted noise levels were found to be meeting applicable standards with respect to land use criteria. The noise impact from NBBL operation during day time is expected to be **negligible to minor**. Furthermore, noise levels at night time will be slightly higher than the applicable standard (with < 5 dBA increase from the applicable standard) at 6 locations. Due to this the noise impact from NBBL operation during night time is expected to be **minor to moderate**.

Impact	<i>Noise from Operation of Plant (Daytime)</i>				
Impact Nature	Negative		Positive	Neutral	
Impact Type	Direct		Indirect	Induced	
Impact Duration	Temporary	Short-term	Long-term	Permanent	
Impact Extent	Local	Regional		International	
Impact Scale	Maximum impact zone within 100 m from project boundary				
Impact Magnitude	Positive	Negligible	Small	Medium	Large
Resource/ Receptor Sensitivity	Low		Medium	High	
Impact Significance	Negligible	Minor	Moderate	Major	
	Significance of impact is considered <b>negligible to minor</b> .				

Impact	<i>Noise from Operation of Plant (Night time)</i>				
Impact Nature	Negative		Positive	Neutral	
Impact Type	Direct		Indirect	Induced	
Impact Duration	Temporary	Short-term	Long-term	Permanent	
Impact Extent	Local	Regional		International	
Impact Scale	Maximum impact zone within 100 m from project boundary				
Impact Magnitude	Positive	Negligible	Small	Medium	Large
Resource/ Receptor Sensitivity	Low		Medium	High	
Impact Significance	Negligible	Minor	Moderate	Major	
	Significance of impact is considered <b>minor to moderate</b> .				

### Mitigation Measures

To mitigate operational noise impacts the detailed design specifications will have the following measures in place:

- Selection of equipment with lower sound power levels (< 85 dB);
- Installation of mufflers on engine exhausts and compressor components;
- Installation of acoustic enclosures for equipment (e.g. gas turbine, compressor) casing radiating noise;
- Buildings will be designed with improved acoustic performance and sound insulation will be provided;

- Installation of acoustic barriers without gaps and with a continuous minimum surface density in order to minimize the transmission of sound through the barriers;
- Barriers will be located as close to the source ,as far as practicable, to be effective;
- Installation of vibration isolation for mechanical equipment; and
- A noise analysis of all major plant components will be carried out during commissioning of the plant to ensure compliance with the specification and guaranteed performance as well as ambient noise levels at the receptors located in the surroundings.

### *Residual Impacts*

Criterion	Rating pre mitigation	Rating post mitigation	Comment
<b>Change in Ambient Noise Levels during daytime</b>			
Residual Impact	Negligible to Minor	Negligible	With implementation of the precautionary and the mitigation measures mentioned for prevention/reduction in noise generation at source impacts would be negligible.
<b>Change in Ambient Noise Levels during night time</b>			
Residual Impact	Minor to Moderate	Negligible to Minor	With implementation of the precautionary and the mitigation measures mentioned for minimizing the noisy activities at night time and limiting the construction activities upto suggested time span, the residual impacts would be negligible to Minor.

## 6.4.6 *Electric and Magnetic Field (EMF)*

### *Sources of Impact*

An electric field is said to exist in a region of space if an electrical charge, at rest in that space, experiences a force of electrical origin (i.e., electric fields cause free charges to move). The electric field will be created by a the sub-station and 230 kV high-voltage transmission line which extends from the energised conductors to other conducting objects such as the ground, towers, vegetation, buildings, etc.

Magnetic fields can be characterized by the force they exert on a moving charge or on an electrical current. As with the electric field, the magnetic field is a vector quantity characterized by both magnitude and direction. Electrical currents generate magnetic fields. In the case of sub-station and transmission lines the 60-Hz electric current flowing in the conductors generates a time varying, 60-Hz magnetic field in the vicinity of these sources.

### *Prediction of Impact*

Short-term effects from transmission-line electric fields are associated with perception of induced currents and voltages or perception of the field.

Induced current or spark discharge shocks can be experienced under certain conditions when a person contacts objects in an electric field. Such effects occur in the fields associated with transmission lines that have voltages of 230-kV or higher. These effects could occur infrequently under the existing 230 kV transmission line. It is understood that potential impacts of electric fields are being mitigated through grounding policies and adherence to the regulatory requirements.

Magnetic fields associated with transmission and distribution systems can induce voltage and current in long conducting objects that are parallel to the transmission line. As with electric-field induction, these induced voltages and currents are a potential source of shocks. A fence, irrigation pipe, pipeline, electrical distribution line, or telephone line forms a conducting loop when it is grounded at both ends. The earth forms the other portion of the loop. The magnetic field from a transmission line can induce a current to flow in such a loop if it is oriented parallel to the line. If only one end of the fence is grounded, then an induced voltage appears across the open end of the loop. The possibility for a shock exists if a person closes the loop at the open end by contacting both the ground and the conductor. The magnitude of this potential shock depends on the following factors: the magnitude of the field; the length of the object (the longer the object, the larger the induced voltage); the orientation of the object with respect to the transmission line (parallel as opposed to perpendicular, where no induction would occur); and the amount of electrical resistance in the loop (high resistance limits the current flow). Knowledge of the phenomenon, grounding practices, and the availability of mitigation measures mean that magnetic-induction effects from the existing 230-kV transmission line would be minimal.

### *Mitigation*

Occupational health and safety EMF standards in EHS guidelines on thermal power and electric transmission lines is suggested to be adhered to and referred for following the best practices.

### ICNIRP Exposure limits for occupational exposure to EMF

Frequency	Electric field	Magnetic Field
50 Hz	10,000	500
60 Hz	8300	415

Source: ICNIRP (1998): "Guidelines for limiting exposure to time-varying electric, magnetic, and electromagnetic fields (up to 300 GHz).



*Habitat Disturbance due to project operation*Context

The operational phase will involve water intake (384 m<sup>3</sup>/hour- 0.1% of the flow of the Dehular Khal) from Dehular Canal for use in process and will release treated waste water (75 m<sup>3</sup>/hr) back to Dehular Khal. The treated waste water discharge will have higher temperature than the ambient temperature, which could impact the aquatic life (fishes and shrimps) in Dehular Khal. Beside monthly twice vessel movement for High Speed Diesel transportation to project site is also planned.

Receptor

At total of 70 species of fish have been reported from the Dheular Khal. The Khal is also used for Shrimps (*Macrobrachium rosenbergii*) catch. It is also a habitat for Two-spot Barb (*Puntius ticto*) fish, an IUCN Vulnerable 2016.v3 species which are available in low numbers. A total of 14 species of phyto planktons and 13 species of zooplankton were observed in the Dehular Khal (Table 4.20) in ecological baseline section.

Embedded Controls

Treated waste water discharge will comply to Discharge temperature should be kept within Schedule 3 (a), 9 and Schedule 10 of ECR, 1997 and IFC EHS guidelines for thermal power plants and general guidelines.

Significance of Impacts

Raw water intake structures can result in aquatic organisms such as fishes drawn into cooling water intake structures through suction and get entrap and killed. The Dehular khal bears 70 fish species including IUCN listed vulnerable species Two-spot Barb (*Puntius ticto*) which may be at harmed. These species are also under threat by treated waste water discharge with elevated temperature. The elevated temperature in aquatic bodies influences fish assemblages by altering composition and decreasing richness. Thermal discharge might be resulted into the disturbance in physicochemical constituents of water body, affecting species composition including zooplankton and macro-fauna such as fish. The temperature change in water affects spawning period of benthic macrofauna. Benthic organisms being sedentary animals associated with sediment bed provide an understanding of integrated effects of stress, and hence serve as good bio-indicators of early warning of potential damage<sup>(1)</sup>. A reduction in dissolved oxygen may affect larger specimens more than smaller fish as these may be able to access oxygen richer water at the surface, at least for a short time. A fish kill can occur with rapid fluctuations in temperature or sustained high temperatures.

(1) Hoffmeyer, M.S., F. Biancalana and A. Berasategui (2005). Impact of a power plant cooling system on copepod and meroplankton survival, Bahia Blanca estuary, Argentina. Iheringia, Ser. Zool. Porto Alegre, 95, 311-318.

Bhola-II power plant will withdraw water from Dehular Canal through a water intake pontoon at the south-west corner of the project boundary and will discharge a constant cooling water discharge flow rate 0.021 m<sup>3</sup>/s and a temperature rise or excess temperature  $\Delta T$  of approximately 3°C to the surface water in the canal. Currents and tides in Dehular Canal indicate a diurnal cycle. Meteorological conditions (particularly wind speed) also plays an important role is mixing of the hot water after meeting with the surface water. Based on similar assessments for cooling water discharges, it was noted that the impact zone, i.e. area of water surface with excess temperature  $\Delta T$  of 1°C, during the average wind conditions (about 2.0 - 2.2 m/s) and during worst case scenario (calm wind) will be about 40-50 m<sup>2</sup> and 130-150 m<sup>2</sup> respectively. Low spread of impact zone is primarily due to small discharge amount (0.02% of the total flow of Dehular Canal). Therefore, the excess temperature will equalize with the ambient water temperature within 50 m of discharge point.

Impact assess is negative and both direct and indirect on the aquatic organisms. Impact will be long term in duration as it covers entire operation phase. Impact extent is local as the elevated water will equalize at a short distance from discharge. The impact magnitude thus arrived is medium. The receptor sensitivity for habitats is low due to absence of any protected area. It is medium due to presence of IUCN listed vulnerable species in Khal. Impact significance thus arrived is **Minor** for habitats and **Moderate** for species.

**Table 6.28** *Impact due to Habitat Disturbance*

Impact	Habitat Disturbance				
Impact Nature	Negative	Positive	Neutral		
Impact Type	Direct	Indirect		Induced	
Impact Duration	Temporary	Short-term	Long-term	Permanent	
Impact Extent	Local	Regional		International	
Impact Scale	Limited to water intake area and waste water discharge area				
Frequency	Operation phase				
Likelihood	Likely				
Impact Magnitude	Positive	Negligible	Small	Medium	Large
Resource Sensitivity (Habitat)	Low	Medium		High	
Resource Sensitivity (Species)	Low	Medium		High	
Impact Significance	Negligible	Minor	Moderate		Major
	Significance of impact is considered for <b>Minor</b> for Habitats and <b>Moderate</b> for Species				
Residual Impact Magnitude	Positive	Negligible	Small	Medium	Large
Residual Impact Significance	Negligible	Minor	Moderate		Major
	Significance of residual impacts is considered <b>Negligible</b> for Habitat and <b>Minor</b> for Species				

Residual impacts will be **Negligible** for habitats and **Minor** for species by implantation of following mitigation measures.

#### Mitigation measures

##### *Intake of Water*

- The water intake structure should have multiple size screen barriers to avoid impingement or entrainment of aquatic organism;
- Usage of barrier nets (seasonal or year-round), fish handling and return systems, fine mesh screens, and wedge-wire screens, and aquatic filter barrier systems should be explored in the water intake system;

##### *Discharge of Waste*

- Options for discharging water should use multiple port diffusers instead of the single point discharge should be explored;
- Options for extended length of discharge channel before reaching Dehular Khal is suggested to be explored;
- Usage of biocides should be reduced and kept to the extent required. Monitoring of the same in waste water discharge is suggested before reaching Dehular Khal;
- Options of utilizing the treated waste water to gardening needs to be explored through sprinkler system should be explored.

## 6.5

### *ASSESSMENT OF SOCIO-ECONOMIC IMPACTS*

The assessment of socio-economic impacts has been undertaken with respect to the receptors across natural capital, human capital, social capital, economic capital and physical capital to have a significant interaction with the activities linked to the project across its lifecycle. The existence of the BPDB CCPP Power Plant (Bhola I) is also an important aspect of the socio-economic baseline, especially in view of the local community's perceptions towards the land procurement process, employment and business opportunities, community health & safety and land-use change.

These impacts have been identified through consultation with the project proponent, project affected persons (including land owners and land users), with government officials (Upazila level), elected representatives Upazila and Union Parishad level and opinion leaders in the area/region and focus group discussions (FGDs) with community people and fishermen community. The impacts are documented from the examination of available information provided by NBBL as of January 2017, socio-economic survey (to establish the pre-project baseline) and feedback received from the stakeholder consultations (see Annex U).

While there are certain impacts that may be relevant for the pre-construction and construction phase, these are illustrated in a consolidated manner to enable a holistic assessment of the socio-economic impacts from NBBL's power plant in view of changes that have already taken place during the construction and ongoing operations of Bhola I.

## 6.5.1

### *Loss of Land*

#### *Context*

As discussed in *Section 3.6.1*, the land requirement for the Project is estimated to be approximately 22.78 acres for the main project components and associated facilities. A majority of this land (11.5 acres) is in the process of being transferred from BPDB (from its available land area in the boundary of Bhola I) for this project and a land lease agreement will be executed within NBBL. This land area is part of the initial land acquisition (32.84 acres) that had been undertaken by BPDB prior to 2007.

NBBL has identified that an additional 5.78 acres of land is required for the Power Plant and the Access Road to the site – 4.72 acres of land parcel on the northern side and 1.06 acres of land along the embankment of the BPDB power station. These land parcels are private owned and have been purchased by NBBL from 63 land owners against 21 sale deeds.

**Note:** NBBL has indicated that the land procurement process was on the basis of voluntary land transactions and willing buyer, willing seller negotiations. However, considering that these specific land parcels were identified (linked to the plant configuration and the land already available with BPDB), the procurement is categorised as negotiated settlement. This is because; NBBL could have applied for land acquisition under ARIPO, 1982 in case the land owner had refused to sell. Although the portion of land purchased is triple cropped, this area was selected as it is in continuation to the land parcel that has is being transferred by BPDB to NBBL.

Discussions with land owners, local authorities (i.e. the Upazilla Chairman) and the project proponent indicated that prices paid to the 63 land owners were reportedly higher than the prevailing market rates. Land was procured directly from 63 land owners and it was reported by the land owners, Upazila Chairman and the project proponent that prices higher than market rates were provided for the procurement of land parcels.

In addition to the above land, another 5.5 acres of land will be acquired through the government's land acquisition process for Right of Way (RoW) for laying of gas pipeline from Shahbazpur Gas Field to NBBL's site parallel to the existing Sundarban Gas Company Limited from gas field to BPDB Bhola I CCPP. Out of the 5.5 acres; 3.31 acres is privately owned and the ownership survey for gas pipeline by NBBL indicated that a total of 132 landowners will be impacted for land acquisition for RoW for the gas pipeline. The land acquisition process for the RoW is yet to be initiated (January 2017).

The distribution of land owners impacted because of land acquisition for plant and gas pipeline as per Unions is provided below:

**Table 6.29 Land Owner Distribution as per Union**

Union	Plant Site Land Owners	Gas Pipeline Land Owners	Total
Kutba	41 (13 sale agreements)	55	96
Sachra	22 (8 sale agreements)		22
Kachia	-	53	53
Deula	-	1	1
Pakshia	-	4	4
Data not available	-	19	19
<b>Total</b>	<b>63</b>	<b>132</b>	<b>195</b>

Source: NBBL

The land requirement for the power plant and associated facilities will result in the following impacts:

- The land area of 5.78 acres land purchased for the plant is in Kutba Union (although there some land owners are living in Char Ghazipur village of Sachra union); it is 0.13 percent of the total Net Cropped Area of Kutba Union (4367 acres), which is negligible. In general, consultations indicated that there is land available in the project’s area of influence to resume cultivation;
- Land loss related to impact for construction of gas pipeline is anticipated to be temporary during the construction phase – the land acquired for right of way for laying of gas pipeline will be returned to the farmers after completion of work, and the farmers can resume cultivation, however no structural developments will be permitted. The gas pipeline will impact 132 land owners due to the right of way acquisition.

Impact	<i>Loss of Land</i>				
Impact Nature	Negative	Positive		Neutral	
Impact Type	Direct	Indirect		Induced	
Impact Duration	Temporary	Short-term	Long-term		Permanent
Impact Extent	Local	Regional		International	
Impact Scale	195 land owners will be impacted (63 land owners for plant site and 132 land owners for gas pipeline right of way)				
Frequency	During the pre-construction phase and the construction phase				
Impact Magnitude	Positive	Negligible	Small	Medium	Large
Resource Vulnerability	Low		Medium		High
Impact Significance	Negligible	Minor	Moderate		Major
	Significance of impact is considered <b>minor</b> as there is titled land availability in the vicinity.				

#### *Change in Land Use and Fragmentation of Land*

The establishment of the project will result in permanent change in land use of the project site and planned sub components areas (like access road, gas pipeline etc.) from agricultural to industrial. The project development is also likely to result in land use change in the adjacent vicinity due to potential increase in economic and commercial activities.

The direct resultant impact (adverse) of land use change in the project area (and the other planned components) is the reduction in land area available for cultivation and resultant livelihood impacts on land owners and *Bargadars*; however the magnitude of impact would be negligible in comparison to the net land area available for cultivation in Kutba Union [0.13 percent (5.78 acres) of the total Net Cropped Area of Kutba Union will change land use from agricultural to industrial]. Industrialisation in the region will also have a positive impact in terms of increase in employment and allied opportunities, better infrastructure and amenities, etc. whose benefits are not only restricted at the local site level but also at the Upazila level.

Laying of gas pipeline will not significantly impact in change in landuse along the RoW, as the land will be returned to the owners after construction is complete and it can be redeveloped for growing crops and grazing. However, there will be restrictions linked to the following aspects:

- 132 are impacted due to the right of way of the earlier BPDB pipeline corridor and the additional 3 m corridor for NBBL;
- Parcels of land along the proposed RoW for gas pipeline may get fragmented due to the linear acquisition associated with the route of the gas pipeline. This may either lead to partial loss of cultivable land or even creation of orphan lands which may be rendered too small or unviable for cultivation;
- The presence of multiple pipelines and the restrictions on the use of land is likely to result into a reduction in the loss of land value for private land parcels.

#### *Embedded Controls*

NBBL has incorporated the following avoidance mechanisms to reduce the overall land requirements:

- Use of existing land parcels availability with BPDB and a resultant decrease in the impact of additional land required for the power plant as a whole;
- Use of BPDB's existing gas pipeline corridor which will minimize the right of way requirement for the laydown area at the time of construction and for the pipeline requirement itself.

#### *Impact Significance*

Impact	<i>Fragmentation and Linear Impacts</i>			
Impact Nature	Negative	Positive	Neutral	
Impact Type	Direct	Indirect		Induced
Impact Duration	Temporary	Short-term	Long-term	Permanent
Impact Extent	Local	Regional		International
Impact Scale	The pipeline right of way will be 5 km in length and 3 m wide			

Frequency	During the pre-construction phase and the construction phase there will be impacts on the ability of land owners to use the land, however, the reduction in land value due to multiple pipelines and restrictions is likely to continue during the operations phase.				
Impact Magnitude	Positive	Negligible	Small	Medium	Large
Resource Vulnerability	Low		Medium	High	
Impact Significance	Negligible	Minor	Moderate	Major	
	Significance of impact is considered <b>Moderate</b> as the exact nature of impacts is not known as the route of the pipeline corridor is yet to be finalised.				

### *Mitigation Measures*

It is understood that while Sunderban Gas Company will acquire the right of way for the gas pipeline, the compensation for loss of assets and for the right of way will be paid by NBBL. NBBL will implement the mitigation measures suggested within the Resettlement Framework to compensate for the impact of land fragmentation due to the pipeline corridor with respect to:

- Consideration of the implications of loss in land value due to multiple pipelines and the restrictions in use of the land within the compensation to be paid to land owners;
- Application of avoidance criteria to ensure that the pipeline route does not lead to unviable land parcels; and
- Avoid valuable land such as homestead and orchard land.

NBBL will implement the safeguards provided in the Resettlement Framework for the project in order to minimise the impacts from loss of land.

### 6.5.2 *Physical Displacement*

The access road for the project and the right of way for the gas pipeline are likely to impact five (5) households. The route of the pipeline has been finalised in alignment along the existing BPDB pipeline. There is one (1) household structure on the access road route on the eastern edge of the BPDB plant.



Figure 6.20 Type of Structures Impacted



Consultations with the affected households as a part of the socio-economic survey indicated that the impact to homestead land and residential structures will be compensated and that alternate structures will be constructed in the balance land which is also under private title.

Impact	<i>Physical Displacement</i>				
Impact Nature	Negative	Positive		Neutral	
Impact Type	Direct	Indirect		Induced	
Impact Duration	Temporary	Short-term	Long-term		Permanent
Impact Extent	Local	Regional		International	
Impact Scale	5 households along the access road and pipeline				
Frequency	During the pre-construction phase				
Impact Magnitude	Positive	Negligible	Small	Medium	Large
Resource Vulnerability	Low	Medium		High	
Impact Significance	Negligible	Minor	Moderate	Major	

Significance of impact is considered **minor** as there is titled land availability in the vicinity of the access road and the pipeline right of way.

### *Mitigation Measures*

NBBL will implement the safeguards provided in the Resettlement Framework by supporting the affected households in self-relocation to adjacent land parcels with formal titles based on the indicated safeguards. Compensation at replacement cost will be provided for homestead land and the residential and associated structures to enable the household to construct replacement housing. Additional safeguards for assisted self-relocation as provided in the Resettlement Framework will be implemented and monitored.

### **6.5.3** *Economic Displacement*

#### *Land Owners*

The land requirement of 5.78 acres (power plant and access road) has impacted approximately 63 land owners that reside in Dakshin Chhoto Monika and Chhaghla village in Kutba Union and Char Gazipur village in Sachra Union. The total population of these three villages is 5050; that means only 1.24 percent people have sold their land which is very low in comparison to the total population of the three villages.

Consultation with the land owners suggests that most direct impact in terms of land loss will be partial loss due to non-availability of 1/4<sup>th</sup> share of the crops produce by the Bargadars that they received. This share received from the Bargadars is sold and the land owner families derive income from the sale. Consultations suggest that loss of income or livelihood was not expected to be significant as the land owners would not be rendered landless, due to selling of these land parcels – they have other additional land for cultivation. Additionally the land owners also harvest income from beetle-nut and coconut plantations and beetle leaf plantations. However, NBBL does not have an inventory of impacts associated with each land owner and hence, potential economic vulnerability from loss of land cannot be excluded.

Significant adverse impact from loss of land of 132 land owners for the ROW for the gas pipeline is not envisaged because of the temporary nature of acquisition. However, there would be short term losses primarily resulting from disruption or severance of access to farm land during the construction phase of the pipeline.

#### *Embedded Controls*

It is understood that NBBL has already executed 21 land sale agreements with 63 land owners where approximately five (5) times of the prevailing government rate was paid as compensation (as reported by stakeholders and the project proponent). The compensation was negotiated with land owners directly and reportedly also included compensation for impacted assets.

Impact	<i>Impacts on Land owners</i>				
Impact Nature	Negative		Positive	Neutral	
Impact Type	Direct		Indirect	Induced	
Impact Duration	Temporary	Short-term	Long-term	Permanent	
Impact Extent	Local	Regional		International	
Impact Scale	Approximately 63 land owners for the power plant and access road and 132 land owners for the right of way of the pipeline				
Frequency	During the pre-construction phase				
Impact Magnitude	Positive	Negligible	Small	Medium	Large
Resource Vulnerability	Low		Medium	High	
Impact Significance	Negligible	Minor	Moderate	Major	
	Significance of impact is considered <b>minor</b> as the total number of land owners impacted represents a small proportion of the overall population. In addition, consultations did not indicate economic vulnerability due to loss of livelihood or landlessness.				

### *Mitigation Measures*

NBBL will undertake a socio-economic survey of all land owners for the power plant, the access road and the gas pipeline route once finalised in order to determine any economic vulnerability or loss of livelihoods due to the land loss. The land owners will be categorised into specific impacted categories as provided in the Resettlement Framework and will be eligible for the following entitlements over and above the land-based compensation that has been received:

- Payment of compensation prior to taking possession of land;
- Reimbursement of registration cost for purchase of land (up to the land lost to the project) within a specified period to encourage usage of compensation amount for building productive asset;
- Payment of transition allowance in case economic vulnerability with respect to loss of livelihood and landlessness is established;
- Dissemination of information about the acquisition and compensation calculation process;
- Eligibility for livelihood restoration measures; and
- Allow land owners to cultivate the gas pipeline RoW with adequate information disclosure on their duties, responsibilities and safety precaution.

For the construction of pipeline, in addition to the right of way, any adjacent land or assets damaged at the time of construction will be compensated at replacement value. There will be additional entitlements with respect to a top up in compensation due to multiple pipelines, land fragmentation or creation of unviable land parcels and loss of land value. Prior information will be provided (at least one month's notice) before commencement of construction.

### *Livelihood Loss of Land Users, Bargadars and Lessee Farmers*

The parcel of land on the northern side is under cultivation (triple cropped, mostly cultivated by 'bargadars' – i.e. leasing land parcel for one cropping season in return of 1/4th share of total produce). *Bargadars* and Lessee Farmers who are cultivating on the land area purchased for the power plant and the access road will not be able to continue with the practice once the construction activities start. Restriction on use of land in project area will lead to a short-term impact on their livelihood and income. This impact may be temporary i.e. loss of income during the transition phase and could be mitigated once the *bargadars* and the lessee farmers finds a new site for cultivation and renews his contract cropping practices. However, the impacts could also be long term and in some instances lead to change in occupational pattern (like cultivator to agricultural, wage labour, contract worker etc) if any *bargadar* is unable to find alternate land.

### *Embedded Controls*

Land users or *bargadars* have not been considered as a part of the compensation provided to land owners. For the gas pipeline, the local land acquisition regulations in Bangladesh do not prescribe any specific entitlements for land users that have informal and undocumented rights on the land.

Impact	<i>Impacts on Land users</i>				
Impact Nature	Negative	Positive	Neutral		
Impact Type	Direct	Indirect		Induced	
Impact Duration	Temporary	Short-term	Long-term	Permanent	
Impact Extent	Local	Regional		International	
Impact Scale	There are approximately 15 land users impacted by the 5.78 acres of land. However, the details of land users along the pipeline are not known.				
Frequency	During the pre-construction and construction phase				
Impact Magnitude	Positive	Negligible	Small	Medium	Large
Resource Vulnerability	Low	Medium		High	
Impact Significance	Negligible	Minor	Moderate	Major	
	Significance of impact is considered <b>moderate</b> as land users or bargadaars do not necessarily have alternate land or means to resume their livelihoods.				

### *Mitigation Measures*

NBBL will enumerate land users across all land parcels impacted and will consider the following entitlements as provided in the Resettlement Framework:

- Consideration of informal rights of the land users for any standing crops, trees (e.g. papaya trees) or structures that are owned by them;

- Payment of a transition allowance of 6 months of the prevailing skilled worker wage rates to support the short-term economic loss till gainful alternate livelihoods are found;
- Prior information to harvest the crops or compensation for loss of crop;
- Option for work during project construction period or skill improvement training.

#### 6.5.4 *Fishing Livelihoods*

Bhola being the biggest delta island district, fishing is also a primary occupation to many of its population, especially practiced by those who have close proximity to the water ways. *Dehular Khal* or Canal passes through the project area, the project site is basically on the banks of the canal; *Dehular Khal* joins Tetulia River in the north and Bay of Bengal in the south. *Dehular khal* is used by the villagers located adjacent to it for navigation, watering the agricultural fields and fishing. However major fishing is done at Tetulia River in the east and Meghna River in the west of Bhola island district.

Dakshin Chhoto Monika village in Kutba Union has a small population of fishermen community. There are about 12 fishermen households in the village who use small wooden non-motorised boats for fishing mostly in Tetulia River. The fishermen go for daily fishing twice a day during the high tides and the fish catch is about 35 to 40 kg per day. They catch fish at *Dehular Khal* also - katha fishing and using push back net is the most common practice. Small fishes and shrimps are the usual catch from the *Dehular khal* that are sold by the fishermen at local markets.

During the construction phase, sand from the Tetulia River will be required for raising the level of the site from the existing level. Dredging may be required for the same; this may temporarily drive away the fish. However according to the Upazila Fisheries Officer this will eventually help in fish migration and breeding of fish in the river. According to the Fisheries Officer dredging will help to remove the natural obstruction under water which will help in easy movement of the fish and fish breeding. However, if dredging is done from the side of the river bank then there may be a chance that a side of the bank may get eroded – but this may not impact the fishing in the river or the fishermen. Impact is expected to be minor in terms of fish catch.

The assessment of ecological impacts has ascertained that there will be minor impacts due to habitat disturbance in the Dehular Canal and the Tetulia river at the time of construction.

During the operations phase, NBBL's power plant will discharge water into Dehular Khal. Discharge water from the power plant will be 2 to 3<sup>0</sup> C higher than the normal water temperature of the khal. Presently, there is limited thermal plume modelling to ascertain the cumulative impact of the effects of BPDB and NBBL's inlet and outlet. However, it is understood that the intensity of fishing in Dehular Canal is not major and that it is used for

subsistence fishing for self-consumption or as a way to reach the Tetulia River where a majority of the fishing activity is carried out.

Impact	<i>Impacts on Fishing</i>				
Impact Nature	Negative	Positive	Neutral		
Impact Type	Direct	Indirect		Induced	
Impact Duration	Temporary	Short-term	Long-term	Permanent	
Impact Extent	Local	Regional		International	
Impact Scale	The impact is likely to be limited to Dehular Canal				
Frequency	During the Operations Phase				
Impact Magnitude	Positive	Negligible	Small	Medium	Large
Resource Vulnerability	Low		Medium	High	
Impact Significance	Negligible	Minor	Moderate	Major	
	Significance of impact is considered <b>minor</b> as Dehular Canal is not the major source of fish catch for the local communities.				

### *Mitigation Measures*

NBBL will put in place the following mitigation measures:

- Conduct a thermal plume modelling to assess the impacts of the inlet and outlet of both the BPDB power plant and the dual-fuel power plant in order to ascertain that there will be no significant increase in temperature and any resultant impact on aquatic habitat and the resultant fish resources;
- During the construction and operations phase, adequate stakeholder engagement measures will be put in place to ensure that the community's access to Tetulia river and to Dehular Canal is not interrupted due to the movement of barges carrying construction material and/or HSD;
- There will be monitoring of fish catch and fish income during the construction phase to ascertain that there is no specific reduction in the resource available to the local community;
- Discharge water should be treated before release so that the Dehular Khal water does not get polluted and also the temperature of the discharge water should be maintained so that fish and shrimp catch in the canal does not get reduced; and
- Good management practices for compensation of fishermen in case of damage to equipment and/or any spillage.

### 6.5.5

#### *Influx and In-migration*

Out of the total labour requirement of 1500 (during peak construction), it is expected that about 25% would be sourced from other parts of Bangladesh. The migrating labour population will primarily consists of more skilled labour workforce while unskilled workforce would be mostly procured locally through local contractors. The labour camps and accommodation facilities for skilled workers will be located outside the power plant complex as a part of the project design. The impact severity is assessed to be moderate as direct



interface with local community will potentially be observed/relevant. The labour influx will be for short term and they would return back to their home provinces at the end of construction period.

However, in view of the feedback from public consultations for the changes during the construction of the BPDB power plant, NBBL's project is expected to stimulate in-migration as contractors and workers mobilize in order to benefit from the following real and perceived opportunities:

- **Local project labour requirements** will exercise a strong attraction due to the scale of actual and perceived job opportunities and the likely awareness and general employment expectations associated with the Project. While only a limited number of jobs will actually be accessible to unskilled and semi-skilled workers considering the nature of activities in the construction phase, the expectations around local employment are extremely high, as already confirmed through stakeholder engagement;
- **Project demand for goods and services:** The experience of local procurement through BPDB's contractors has also generated high expectations around opportunities associated with the supply chain. While the Project's demand for goods and services from the area of influence will be small in absolute terms, perceptions of the opportunity are likely to mean it will still be a strong pull factor. As there is very little relevant established business in the area, effective competition from local entrepreneurs is likely to be low;
- **Project improvements in local physical and social infrastructure:** The Project will facilitate improvements in local physical and social infrastructure, through road improvements etc. and also through community investments and input to local development. These will be very strong pull factors;
- **Concentration of project activities:** The concentration of construction activities around Kutuba Union will focus in-migration to towns and villages in the immediate vicinity of the Project, especially the main municipality town of Burhanuddin Upazilla; and
- **Increased opportunities for incoming entrepreneurs:** The local market has limited capacity to meet project demands for local goods and services, as well as the demands of the increased population. Traders and entrepreneurs from outside the local area will have high expectations around economic opportunities associated with the Project, which may or may not materialise.

The following table summarises key implications of in-migration along with sensitivities within the spatial extent of the Area of Influence (AoI):

**Table 6.9** *Implications of In-migration*

Issue/Implication	Potential Sensitivity	
	Key Settlements (Kutuba Union)	Burhanuddin Upazilla
Significant <b>increase in population:</b> There is likely to be at least a 10-20% change in the	High probability	Moderate probability



Issue/Implication	Potential Sensitivity	
	Key Settlements (Kutuba Union)	Burhanuddin Upazilla
population of the local study area		
Significant implications for the use and availability of land and the associated spatial planning	High probability	High probability
Development of informal settlements	High probability	Low probability
Increase on the pressure on water resources for local communities as a result of the demand for drinking water and water for agriculture from in-migrants	High probability	High probability
Increase in the quantities of solid waste and sewage requiring disposal from the local population, with impacts on land, water and environmental quality at locations where waste is disposed of and sewage effluent is discharged	High probability	Moderate probability
Increased population, demand for goods and services, and constraints on supply as a result of pressure on resources, will all contribute to inflation in local prices	Low probability	High probability
Increased pressure on local infrastructure and services (sanitation, education, health etc) which are all already constrained, increasing pressure on the resources of local government and increasing risks of impacts on health and welfare associated with lack of access to these services	High probability	High probability
Risk of introduction of new diseases into the area and increased transmission and incidence of existing diseases as a result of new people coming into the area who are carriers, transport of disease vectors from other areas, higher population density and possible overcrowding, increased sexual activity, clearance of vegetation	High probability	Moderate probability
Uncontrolled movements of people may lead to more security concerns	Moderate to low probability	Moderate to low probability

### *Proliferation of Informal Settlements*

Influx and in-migration may lead to a proliferation of informal settlers and settlements. During the construction phase, there is a moderate to low probability of squatting, indiscriminate and unplanned erection of houses or structures made of light and disposable materials. These settlements may not conform to local health, sanitation and electrical fitting standards.

Some of the key locations that are likely to be prone to the proliferation of settlements include:

- The access road on the way to the BPDB and NBBL Power Complex Area;
- Villages around the location of the labour camp;
- Villages in Kutuba Union;
- Burhanuddin Town.

During the operations phase, the informal settlers are likely to abandon the area leaving temporary structures behind. If not dismantled and properly disposed, this will pose imminent concerns on the possibility that the abandoned structures will be used as temporary shelter/shed by interested individuals or groups (e.g. local teenagers) informal gatherings or worst a haven for any illegal activity in the area. They may also become Safety and Fire Hazards.

#### *Threat to Delivery of Basic Services and Resource Competition*

The availability of basic services in the socio-economic baseline has indicated certain limitations in the adequacy, arrangement and quality of these services. There is likely to be considerable impact and pressure on the delivery of services during the construction phase due to the need to balance existing population and growing host community requirements, informal settlers, construction workers and camp followers along with the project's construction and operations requirement.

Specifically, critical services that will result into resource competition will include irrigation and potable water supply, power supply, health resources, communication and security.

In-migration and the demand for goods and services will also give rise to positive impacts, such as increased economic development and diversification, as witnessed through present level of industrial activity. Particularly:

- Rent seeking opportunities for local communities (both residential and commercial);
- Probability of increased demands for basic household services in the area, thereby creating income opportunities;
- In- Migration also has the potential for bringing people together socially and culturally but difficulties and friction may occurs if efforts are not made to properly inform them of the customs and tradition in the locality.

A proportion of the in-migrants and informal settlers are likely to live permanently in the host communities and may continue to add demands on goods and services.

#### *Embedded Controls*

NBBL will be able to influence the EPC contractor to set up labour camps in accordance to requirements of international standards. In addition, as the gas pipeline route is only 5 km, it is unlikely that any labour camps will be set up along the way.

During the operations phase, the project will have its own colony/township in Burhanuddin (as a gated community) and there is no specific township proposed.

Impact	<i>Influx and In-migration</i>				
Impact Nature	Negative	Positive		Neutral	
Impact Type	Direct	Indirect		Induced	
Impact Duration	Temporary	Short-term	Long-term	Permanent	
Impact Extent	Local	Regional		International	
Impact Scale	The impact is likely to be limited to Kutub Union and Burhanuddin Upazilla				
Frequency	During the Construction Phase				
Impact Magnitude	Positive	Negligible	Small	Medium	Large
Resource Vulnerability	Low		Medium	High	
Impact Significance	Negligible	Minor	Moderate	Major	
	Significance of impact is considered moderate due to the proposed changes in key indicators of the present baseline inspite of embedded controls due to the high expectations about employment and other benefits from the project.				

### *Mitigation Measures*

The Project will develop a Labour and Influx Management Plan (LIMP) that addresses how the Project will seek to: minimise Project-induced in-migration as far as possible; manage and direct the flow of in-migrants in accordance with the regional planning objectives; and implement mitigation measures to address the adverse environmental and social consequences, and maximise the benefits, of in-migration.

The LIMP will cover the following key elements: labour and contractor management; worker camp development; linkage to enhancement of physical infrastructure; building human capacity to manage influx; monitoring and evaluation of in-migration.

Specific aspects to be included within the LIMP are:

- Provide a list of local skills and names within the unions to the contractors;
- Ensure orientation of workers regarding local cultural practices, ethnic community dynamics, attitude towards women and children etc.;
- Access to a grievance redressal;
- Ensure that all unions around the project footprint are kept informed on the number, identity and other details of workers coming in;
- Worker accommodation will include sources for drinking water, solid waste management, pest control services, camp/curfew rules, adequately equipped medical facility, security and other requirements in line with IFC's Guidelines on Worker Accommodation.

The local authorities will need to be specifically involved and facilitated on their initiatives in influx management:

- Improved waste segregation and regular garbage collection;
- Improvement of barangay drainage system'

- Random Alcohol and Drug Test in the area
- Local Health Units – Regular Check-Up, Health Testing and Hygiene Inspection of Restaurant, Food and Beverages staff/handlers and others;
- Regular fumigation of surroundings;
- Ensure thorough monitoring within the vicinity to take control in proliferation of Informal Settlers and settlements;
- Come up with Dismantling and Clearing Operation Scheme for the immediate dismantling of abandoned structures in the area.

#### 6.5.6 *Community Health and Safety*

Possible sources of impacts to community health and safety during the construction phase are:

- Changes in environmental quality due to construction activities;
- Increased prevalence of disease arising from the influx of construction workers; and
- Heavy traffic movement.

For the operations phase, the risk assessment (Section 9) has already taken into account the potential emergency response and preparedness scenarios.

#### *Receptors*

Project site workers, settlements in close proximity to the Project site (within 500 m) and along the access road (with 100 m) are potential receptors of health impacts from construction related activities. Nearest settlements and households present in close to plant and/or pipeline route are presented below:

Location	Nearest Settlement/ Household	Distance in metres	Direction
Plant	Choto Dakhin Monika	120	North
Plant	Dakkin Kutba	100	East
Plant	One household	10 (Adjacent to the site boundary)	East
Plant	Five shops	20 (adjacent to the front gate of BPDB plant)	East
Pipeline	Chagla, Bara Kachia	Pipeline RoW not provided. Hence, distance not available.	

#### *Implications of Modified Environmental Conditions*

Changes in the environmental quality of air, surface water, groundwater and soil quality may occur as a result of construction activities. High noise levels are also expected from the operation of heavy machinery.

An increase in dust and noise during the construction period has the potential to lead to health impacts associated with eye irritation and general disturbance to daily activities. The dust and noise impacts during the construction phase are assessed and discussed and have been mentioned by the community people adjacent to the existing power plant.

The discharge of domestic waste effluent from sanitary facilities for construction workers may have the potential to cause contamination of surface water and groundwater in this area.

#### *Health Risks from Influx and In-migration*

Baseline surveys and consultations revealed that the most common diseases in the Project area are bacillary dysentery, diarrhoea, typhoid, peptic ulcers, pneumonia and bronchial asthma. The greatest incidence is of food and water borne diseases, arising from contamination by faecal elements, pests and vectors and due to lack of sanitation facilities. Such diseases will be of special concern during the monsoon season.

Measures such as proper collection, storage and disposal of wastes, construction of septic tanks to prevent contamination of water resources from sanitary effluents generated from labour camps will be implemented. Mitigation measures will be implemented to reduce the likelihood of contamination of surface and groundwater from sanitary effluents generated during construction. Taking these measures into account, the impact to public health and safety is evaluated to be of medium significance.

The community health and safety impacts from an increased prevalence of diseases are likely to be restricted to the local community in the immediate vicinity of the labour camp and within the construction phase of the project. Furthermore, the impacts should be such that can be mitigated with proper mitigation measures.

#### *Local Traffic Movement*

An increase in local traffic is expected as a result of the construction activities which may create public safety issues for local residents, especially along the access road. Potential impacts include blocking access, congestion and traffic accidents along the access road. The probability of pedestrian traffic accidents is low given that the road is not a busy road; built on a raised embankment of 1.5 m and does not provide direct access to the villages. Furthermore, the impacts from traffic movement are expected to be restricted to the local community in the immediate vicinity and should be manageable with adequate mitigation measures, such as implementation of speed controls (20 km/hr).

The potential health impacts due to a change in the environmental conditions are expected to be of a temporary nature, restricted to the project site and their immediate vicinity. Keeping this in mind, the health and safety impact associated with changes in environmental quality is considered to have *moderate* significance when assessed against the receptors location and the various mitigation measures in place.

Impact	Community health from changes in environmental conditions
--------	---

Impact Nature	Negative	Positive	Neutral		
Impact Type	Direct	Indirect	Induced		
Impact Duration	Temporary	Short-term	Long-term	Permanent	
Impact Extent	Local	Regional	International		
Impact Scale	Limited to Project site and access road vicinity				
Frequency	Limited to Construction Phase and primarily covering dust, noise, waste generating activities and transportation				
Impact Magnitude	Positive	Negligible	Small	Medium	Large
Resource/ Receptor Sensitivity	Low	Medium	High		
Impact Significance	Negligible	Minor	Moderate	Major	
	Significance of impact is considered <b>moderate</b>				

### Mitigation Measures

The following mitigation measures will be put in place to reduce impacts on community receptors:

- Barriers will be provided to prevent ingress of persons into the construction site and also to protect public exposure to hazards associated with construction activities;
- Avoiding formation of stagnant water pools in and around the site;
- Implementation of a vector control programme in labour camps and surrounding areas; and
- Educating area residents and workers on risks, prevention, and available treatment for vector-borne diseases.
- Emphasizing safety aspects among drivers, particularly with regard to the speed limit of 20 km/hr that will be enforced;
- Ensuring that only licensed drivers are employed by the Project;
- Avoiding peak hours for heavy vehicles movement where possible;
- Collaboration with local communities and responsible authorities to improve signage ( e.g. pedestrian crossings, speed limits etc.), visibility and awareness of traffic and pedestrian safety;
- Educating project personnel and area residents on risks, prevention, and available treatment for vector-borne diseases.
- Screening, surveillance and treatment of workers, through the provision of medical facilities and, where required, immunization programmes.

### Residual Impacts

Criterion	Rating pre mitigation	Rating post mitigation	Comment
<b>Loss of Land</b>			
Residual Impact	Minor	Negligible	The project has already considered embedded controls and alternatives to minimize land requirements.
<b>Land use change and increase in fragmentation</b>			
Residual Impact	Moderate	Minor	Avoidance measures and implementation of the Resettlement Framework will need to be undertaken

Criterion	Rating pre mitigation	Rating post mitigation	Comment
<b>Physical Displacement</b>			
Residual Impact	Minor	Negligible	Avoidance measures to reduce the number of households to be impacted.
<b>Economic Displacement</b>			
Residual Impact	Moderate	Minor	With implementation of the Resettlement Framework and disbursement of additional entitlements for those deemed as economically vulnerable.
<b>Fishing Livelihoods</b>			
Residual Impact	Minor	Negligible	Operational phase impacts to be determined based on conduct of additional studies
<b>Influx and In-migration</b>			
Residual Impact	Moderate	Minor	With implementation of the precautionary and the mitigation measures mentioned for prevention/reduction of impact magnitude, impacts would be minor.
<b>Community health impacts associated with environmental conditions</b>			
Residual Impact	Moderate	Minor	With implementation of the precautionary and the mitigation measures mentioned for prevention/reduction of impact magnitude, impacts would be minor.

### 6.5.7

#### *Local Economic Benefits*

##### *Employment Generation*

Employment generation will be a significant contribution of the project, especially considering that the employment scenario in project area during the construction phase. The project is expected to employ at least about 500 unskilled and semi-skilled labours during the construction phase and additional 40-50 local persons for the operations phase through contractors. The potential impacts due to the employment generation are considered to be positive.

##### *Benefits of Local Enterprise*

The construction phase influx is likely to provide a stimulus to the local economy. Influx and in-migration and the flurry of construction work is likely to raise wage levels and may also result into localized inflation of the prices for basic goods during a temporary period where demand of consumables may exceed supply. This also includes agricultural produce, demand for meat and poultry as well as fish. Thus large farmers will have a ready market to supply their produce.

Local enterprises, particularly those involved in the production and sale of construction materials, are potential benefactors of the civil works involved in the project. Brick-making provides employment to a large number of local unskilled labours. Similarly, stone crushers, sand suppliers and local transporters of these materials will also benefit from the project. Also food suppliers who



provide raw food materials to the labour camps and construction and commissioning workers' canteens will benefit from the project. There has already been a precedence of the same during the development of the BPDB Power Plant.

It is anticipated that with time, the potential exists for local /and regional businesses to develop and grow to meet at least some of the procurement needs of the proposed Project, especially during operations. Procurement locally will assist in creating income and building a more stable and diverse economy. As the proposed Project develops, the increased demand for goods and services should create commercial opportunities for local businesses (those opportunities are likely to be focused on the production and transformation of food products). In addition, the influx of migrant jobseekers will bring people with different experiences, knowledge and demands that will supplement the existing economic and livelihood activities and offer additional activities that will serve to diversify the local economy.

#### *Increase in local skill levels*

The workforce requirement in operation phase requires approximately 20 to 25 un-skilled workers and approximately 49 skilled, technical, professional and executive staff. The nature of employment also changes from temporary contract workers to long-term workers or permanent staff members. This includes technical or executive staff that can be sourced from different parts of the country or can even be expats. Some of them would be residing nearby the plant location or in Burhanuddin. Although the employment generated during this phase would be small in number, it will still account for a *positive* impact on the local employment scenario. Further, this development is going to attract more industries in the proposed industrial park and economic zones due to reliable power availability which will increase the demand for employment in and around Burhanuddin.

#### *Increments in cost of living*

The presence of a salaried working class population will bring in greater cash income in project area. Hence, the spending capability of this population will be higher than the local population which depends on agriculture or household based small scale industries. The spending capacity, in turn will increase local consumption thereby increasing demand for a range of commodities in daily life. This often results in price rises for these regularly consumed items. Hence, the cost of living in the project area may experience an incremental rise.

#### *Opportunity for local transporters*

The project operation will require a number of transportation services including regular requirement for commuting short term visitors and industrial provisioning of a range of materials. Hence, this would create business opportunity for local transporters.

### *Community Benefits*

The electricity produced from the power plants are supplied to the distribution grid and GoB decides on the areas to which the power generated is to be supplied. However, BPDB has provided a local feeder connection of about 30 MW which supports the availability of power from Kutuba Union up to Chaur Fasoon towards Bhola. There will be an increase in the local government's efforts to electricity settlements in view of the demand from the local community.

The local community will also expect an increase in development activities associated with NBBL's social responsibility commitments.

### *Demobilization and transition to the Operations phase*

Construction-related work opportunities will last only in the medium term of 3 years, after which there will be demobilization of construction phase activities due to the requirement of a significantly smaller manpower during the operations phase. The reduction in the workforce will result in the outmigration of workers as they leave to seek job opportunities elsewhere. This may result in the depression of the local economy as the market for local goods and services declines. It may even cause an out-migration of local people who may also leave in search of better economic opportunities elsewhere. Given the limited working opportunities during Project operations, it will be challenging to meet the expectations of the local construction employees. The release of local employment will have impacts on the loss of employment and local labor income; this in turn will influence public perception leading to community unrest.

Transition into operations will involve large scale downscaling and retrenchment of the workforce over a number of years. By that time a large number of local professionals will have worked on the proposed Project, and will constitute a reserve of trained workforce. Demobilization will have a considerable impact on the women and youth, as they will be in the prime of their working lives, with significant earning potential and large demands on their income (i.e., young families).

This positive impact will be enhanced by training received through on-the-job and more formal training courses related to skill development for production and Health and Safety and Environment (HSE) standards required for the proposed Project. This positive impact will include suppliers and Contractor staff, who will have to meet particular production, operational, and quality standards as required by NBBL.

For those national and local companies that have the opportunity to be part of the proposed Project's supply chain, long lasting and sustained benefits to the businesses and their employees can be expected, in the form of enhanced work experience, delivery capacity and training, particularly in having to meet stringent international standards of quality, health, safety and environmental management.

### Impact Significance

Overall the local economic impacts are likely to be positive.

Impact	Impacts on the local economy and skills development				
Impact Nature	Negative	Positive		Neutral	
Impact Type	Direct		Indirect		Induced
	While certain impacts are linked to project activities, ancillary developments in the area of influence may also influence the impact.				
Impact Duration	Temporary	Short-term	Long-term		Permanent
Impact Extent	Site-specific	Local	Regional		International
Impact Scale	The impact represents a major change from the present local economic and skills development scenario.				
Frequency	Routine or continuous impact linked to project activities and procurement requirements with a phase of depression linked to the demobilization.				
Impact Magnitude	Positive	Negligible	Small	Medium	Large

### Enhancement Measures

NBBL should develop and implement a Procurement Plan prior to the start of the construction phase. The Plan should be designed to stimulate and sustain local business during the various phases of the proposed Project and to stimulate capacity and competition amongst suppliers in the Project supply chain.

The main objective of the plan will be to maximise local purchasing, by directly working with local enterprises and by incentivising the Project's contractors to contract locally. To the extent possible, NBBL should unbundle certain contracts to allow a number of small businesses to provide goods and services rather than the supply being monopolised by one large (foreign) contractor.

NBBL should maintain a contact database of all relevant local businesses that could be used as potential suppliers. The project should identify local procurement opportunities and also undertake training and capacity building of the local suppliers.

The Project will properly inform potential workers and suppliers well in advance all the compensation and benefits scheme for temporary construction contract as well as the employment period as in accordance with the Project timeline, while publicly informed community and the workforce on the Project's employment opportunity and requirement for operation phase.

Engage closely with local NGOs to understand the key collective requirements of the surrounding community and identify one or more of the highlighted concerns which NBBL will support to resolve. Some of the collective

requirements could be access to (i) clean drinking water (ii) medical consultation (iii) education, etc.

Communication of a clear plan of action to improve the welfare of the neighbouring community, before commencing construction works on site. Where feasible training will be provided to potential construction workers qualified and able to meet the needs of the operations activities, and to local business which potentially partnering with the Project in provision of goods and services for operation phase.

## 6.6 CUMULATIVE IMPACTS DUE TO OPERATION OF BHOLA-I AND BHOLA-II OPERATIONS

### 6.6.1 Water Resources

#### Criteria

For the assessment of water resources, the sensitivity and magnitude criteria outlined in Table 6.9 and Table 6.10 have been used respectively. The assessment of potential impacts to surface water has considered *Schedule 3 (a), 9 and Schedule 10 of ECR, 1997* (refer to **Table 2.8** and **Table 2.9**). For groundwater, *Schedule 3 (b) of ECR, 1997*, standards for drinking water has been considered.

#### Receptors

**Surface water:** The major surface water body adjacent to the Project site is Dehular Khal. This will be used as means of transport for heavy equipment and temporary jetty constructed on it. Details of the hydrology and drainage pattern in the AOI are discussed in **Section 4.3.5**. Based on the sensitivity assessment criteria described in **Table 6.9** both surface and ground water resource was found to be medium.

#### Impact Significance

##### Water Abstraction from Dehular Khal

Combined water requirement of Bhola-I and II projects will be about 800 m<sup>3</sup>/hr. Based on the previous study, average discharge of Dehular Khal is about 108 m<sup>3</sup>/s. Total water abstraction quantity is therefore only 0.2% of the average flow of Dehular Khal and this amount of intake is negligible in the context of flow of the channel. Therefore based on the impact magnitude criteria described in Table 6.10 and referring to above discussion, the impact of water abstraction on Dehular Khal for the proposed plant would be **negligible**.

Impact	Impact from Surface Water Abstraction (Bhola I and Bhola II Projects)		
Impact Nature	Negative	Positive	Neutral
Impact Type	Direct	Indirect	Induced

Impact Duration	Temporary	Short-term	Long-term	Permanent	
Impact Extent	Local	Regional	International		
Impact Scale	Downstream of Dehular Khal and Project area				
Frequency	Throughout Operation Phase				
Impact Magnitude	Positive	Negligible	Small	Medium	Large
Resource/ Receptor Sensitivity	Low	Medium	High		
Impact Significance	Negligible	Minor	Moderate	Major	
	Significance of impact is considered <b>negligible</b> .				

### Water Pollution from Wastewater Discharge

Since the water requirement of both power plants is almost similar (i.e. about 384 m<sup>3</sup>/hr) and proposed discharge quantity from NBBL project is about 75 m<sup>3</sup>/hr. In addition to that assuming about 100 m<sup>3</sup>/hr of the treated water discharge from Bhola-I project, the total treated wastewater discharge from the complex will be about 175 m<sup>3</sup>/hr, which will be discharged from the respective plant to the Dehular Khal by after treatment. In order to avoid cumulative impact particularly due to hot water discharge (cooling tower blow down, which will be having about 3°C temperature difference from the intake water temperature), the discharge location of Bhola-II power plant has been selected at a distance of 100 m from the Bhola-I power plant. Layout indicating the discharge locations of Bhola-I and Bhola-II power plants is presented in Figure 6.21. Since the impact zone of the thermal pollution will be within 50 m from the discharge location and hence, the cumulative impact will be minimal due to safe distance provision of the two outfalls. Furthermore, blowdown from Bhola-I power plant traverse about 350 m by an open channel before it meets with Dehular Khal, which also helps in reducing the temperature at the outfall location. Also, treated effluent from Bhola-II power plant will be discharged into Dehular Khal via approx. 350 m long 100 NB (4") pipeline from Guard pond (common monitoring basin). In addition to that there will be a separate storm water discharge channel for Bhola-II power plant, which will be connected with the Bhola-I power plant discharge channel.



Impact Scale	Discharge into natural drainage at different locations				
Impact Magnitude	Positive	Negligible	Small	Medium	Large
Resource/ Receptor Sensitivity	Low		Medium	High	
Impact Significance	Negligible	Minor	Moderate	Major	
	Significance of impact is considered <b>minor</b> .				

### Mitigation Measures

Other mitigation measures which will be adopted to reduce impacts on water quality to As Low as Reasonably Practicable are as follows:

- For minimising use of antifouling and corrosion inhibiting chemicals appropriate depth of water intake will be maintained and use of screens will be ensured;
- Minimum required quantities of chlorinated biocides or alternatively intermittent shot dosing of chlorine will be practised rather than continuous low level feed;
- Waste storage areas will be equipped with secondary containment and spill control measures (similar to the hazardous material storage areas) to limit impact to ground;
- Oil water separators will be provided to intercept any accidental discharge of oil and grease on the storm water channels;
- Liquid wastes such as waste oil, etc. will be collected and stored for recycling in cemented areas; and
- All drainage/tanks, etc. will be positioned on concrete hard standing to prevent any seepage into ground.

## 6.6.2

### *Air Quality*

#### *Cumulative Impacts on Air Quality – Operation of Bhola-I and Bhola-II Projects*

#### Sources of Impact

The two projects within Power Complex include one dual fuel fired combined cycle power plant (CCPP), and one natural gas fired CCPP. Emission parameters in combined cycle mode from the four projects are presented in Table 6.30.



**Table 6.30 Summary of Emissions for the Power Plants for Separate stacks within Power Generation Complex**

Fuel	Stack	UTM Co-ordinates* (m)		Stack Height (m)	Stack Internal Diameter (m)	Flue Gas Exit Velocity (m/s)	Flue Gas Temperature (°C)	Volumetric Flow Rate (Nm <sup>3</sup> /s)	Emission Concentration			Emission Rate		
		Easting	Northing						NOx	SO <sub>2</sub>	PM <sub>10</sub>	NOx	SO <sub>2</sub>	PM <sub>10</sub>
									mg/Nm <sup>3</sup>	kg/hr	mg/Nm <sup>3</sup>	(g/s)	(g/s)	(g/s)
NG	NBBL Main Stack 1 (S1)	264263	2487535	55	6	6	373	133	51	-	1.7	6.79	-	0.23
	NBBL Main Stack 2 (S2)	264305	2487552	55	6	6	373	133	51	-	1.7	6.79	-	0.23
	BPDB Main Stack 1 (S3)	264497	2487590	50	6	6	373	133	51	-	1.7	6.79	-	0.23
	BPDB Main Stack 2 (S4)	264531	2487605	50	6	6	373	133	51	-	1.7	6.79	-	0.23
HSD	Main Stack (S1)	264263	2487535	55	6	6	373	133	152	87	50	39	66	12.8
	Main Stack (S2)	264305	2487552	55	6	6	373	133	152	87	50	39	66	12.8

\* UTM Zone - 46

\*\* Stack parameters are as provided by NBBL. Stack height is calculated for NBBL based on SO<sub>2</sub> emission load, which will be generated during plant operation with HSD. It has however been noted that in the updated design, main stack height is considered as 60 m above ground level and this will provide better dispersion conditions for the flue gas. Note: the Bhola-I plant was though operational during the baseline monitoring, however was running with less than 50% load and therefore, to assess the cumulative impacts in worst case scenario, it is assumed that Bhola-I plant was not functional during the baseline monitoring and model predictions for Bhola-I plant also taken into consideration.

### *Criteria*

For the assessment of air quality, the sensitivity and magnitude criteria outlined in *Table 6.11* and *Table 6.22*, respectively have been used. The standards considered for assessment of potential impacts to air quality, are *Schedule 11 ECR, 1997 of the GOB (Table 2.7)*,

### *Receptors*

From the landuse analysis and field study, it is clear that most of the land surrounding the Project site is agricultural land and vegetation covered area. On the immediate east, there is existing power plant (225 MW Bhola I) followed by settlement, which is approximately 150 m from the proposed project site. The immediate south of the Project site has barren land followed by agricultural land. The immediate north site of the Project site has agricultural land followed by village (approximately 150 m from the Project site) and few dwellings within 100 m. The immediate west site of the Project site has Dehular Khal followed by agricultural land and settlement (approximately 400 m from the Project site). As can be referred from *Table 6.11* and above discussion, the human receptors were assessed to be of Medium sensitivity, whereas ecological receptors were considered as of Low sensitivity.

### *Prediction of Impacts*

Impact on ambient air quality due to the NBBL project (gas/HSD), existing gas based BPDB project was evaluated by using air dispersion modelling. Predicted maximum criteria pollutant concentrations due to the Project in the Project AOI with natural gas and HSD as fuel have been presented in *Table 6.31*. Additionally, predicted concentrations at the receptor locations (refer *Table 6.23*) combined cycle operations of these projects with natural gas and HSD as fuel have been presented in *Table 6.31*. Isopleths of ground level concentration for different averaging periods of the criteria pollutants (NO<sub>x</sub>, SO<sub>2</sub> and PM<sub>10</sub>) with natural gas and HSD as fuel are presented in *Figure 6.22* to *Figure 6.31*.

Table 6.31 Predicted Concentrations at Receptors due to Operation of Bhola-I and Bhola-II Projects - with Gas and HSD as Fuel

Scenario	Pollutant	Average	Predicted Concentration (µg/m³)						Max. Background Concentration (µg/m³)*						Total Concentration (Predicted + Background) (µg/m³)					Bangladesh Standard (µg/m³)	WB Standard (µg/m³)
			Max	AQ 1	AQ 2	AQ 3	AQ 4	AQ 5	Max	AQ 1	AQ 2	AQ 3	AQ 4	AQ 5	Max	AQ 1	AQ 2	AQ 3	AQ 4		
NBBL and BPDB Operation with Natural Gas as Fuel	NO <sub>x</sub>	1-hourly	51.0	35.3	29.0	34.7	31.5	25.6	70.6	68.5	59.6	70.7	50.0	61.1	121.6	103.8	88.6	105.3	81.5	-	200
		24-hourly	12.5	8.9	10.0	9.1	7.7	9.6	29.0	28.1	24.5	29.0	20.6	25.1	41.5	37.0	34.5	38.2	28.3	-	-
		Annual	3.7	1.4	3.5	1.3	1.0	2.8	5.6	5.4	4.7	5.6	3.9	4.8	9.3	6.8	8.2	6.8	5.0	100	40
	PM10	24-hourly	0.42	0.30	0.34	0.31	0.26	0.33	42.4	38.2	34.8	41.5	31.5	42.4	42.8	38.5	35.2	41.8	31.7	150	100
		Annual	0.12	0.05	0.12	0.04	0.03	0.10	8.1	7.3	6.7	8.0	6.0	8.1	8.2	7.4	6.8	8.0	6.1	50	50
	NBBL Operation with HSD as Fuel & BPDB Operation with Natural Gas as Fuel	NO <sub>x</sub>	1-hourly	99.1	78.1	67.2	76.8	65.4	60.2	70.6	68.5	59.6	70.7	50.0	61.1	169.7	146.6	126.9	147.5	115.4	---
24-hourly			27.2	20.3	26.1	19.0	16.2	21.3	29.0	28.1	24.5	29.0	20.6	25.1	56.2	48.4	50.5	48.0	36.7	---	---
Annual			7.5	2.5	7.2	2.6	2.2	5.9	5.6	5.4	4.7	5.6	3.9	4.8	13.1	7.9	11.9	8.2	6.1	100	40
SO <sub>2</sub>		24-hourly	29.9	20.5	29.4	17.8	15.2	20.9	16.9	16.3	13.7	16.9	12.6	16.4	46.8	36.8	43.1	34.7	27.8	365	50
		Annual	7.1	2.0	6.7	2.4	2.1	5.6	3.2	3.1	2.6	3.2	2.4	3.1	10.3	5.1	9.4	5.7	4.5	80	---
PM10		24-hourly	8.3	5.7	8.1	5.0	4.3	5.9	42.4	38.2	34.8	41.5	31.5	42.4	50.7	44.0	43.0	46.5	35.8	150	100
	Annual	2.0	0.6	1.9	0.7	0.6	1.6	8.1	7.3	6.7	8.0	6.0	8.1	10.1	7.9	8.6	8.6	6.6	50	50	

\* Refer to Table 4.16

Highlighted cells indicate calculated background concentrations.

Monitoring was carried out for 1 month with 24 hourly averages. Therefore, in order to provide 1-hourly maximum and annual average concentrations, conversions are done using the power law relationship

It is evident from *Table 6.31* that the maximum ground level concentration (maximum baseline concentration + predicted maximum concentration) in the project AOI with natural gas as fuel will be well within the applicable air quality standard. Furthermore, project contribution for all the pollutants considered in the study are < 25% of the applicable air quality standard and therefore, using the determination of magnitude criteria (*Table 6.22*), impact magnitude due to operation of Bhola I and II projects with natural gas as fuel is assessed to be negligible.

Impact	<i>Ambient Air Quality (Cumulative impact due to Bhola-I and Bhola-II projects) with natural gas as fuel</i>				
Impact Nature	Negative	Positive	Neutral		
Impact Type	Direct	Indirect	Induced		
Impact Duration	Temporary	Short-term	Long-term	Permanent	
Impact Extent	Local	Regional		International	
Impact Scale	Maximum impact zone within 2 km from project boundary in the downwind direction				
Likelihood	Possible				
Impact Magnitude	Positive	Negligible	Small	Medium	Large
Resource/ Receptor Sensitivity	Low	Medium		High	
Impact Significance	Negligible	Minor	Moderate	Major	
	Significance of impact is considered <b>negligible</b> .				

While using HSD as fuel, the maximum ground level concentrations (maximum baseline concentration + predicted maximum concentration) of NO<sub>x</sub>, SO<sub>2</sub> and PM<sub>10</sub> will also be within the applicable standard and overall project contribution will be < 25% of the applicable standard. Therefore, using the determination of magnitude criteria (*Table 6.22*), the impact magnitude due to the operation of NBBL project using HSD as fuel is assessed to be negligible. It shall be noted that the Project will be using natural gas as primary fuel and HSD will only be used in case of non-availability of natural gas from SGCL. Furthermore, in the event of a gas supply failure, the facility will not automatically switch to HSD as the decision rests with BPDB whether to operate the Plant on HSD or to pay capacity charges for the period of gas outage.

On this basis, the potential air quality impacts due to the operation of the Plant by using HSD as fuel are predicted to be *negligible*.

Impact	<i>Ambient Air Quality (Cumulative impact due to Bhola-I project with natural gas as fuel and Bhola-II project with HSD as fuel)</i>				
Impact Nature	Negative	Positive	Neutral		
Impact Type	Direct	Indirect	Induced		
Impact Duration	Temporary	Short-term	Long-term	Permanent	
Impact Extent	Local	Regional		International	
Impact Scale	Maximum impact zone within 2 km from project boundary in the downwind direction				

Likelihood	Possible				
Impact Magnitude	Positive	Negligible	Small	Medium	Large
Resource/ Receptor Sensitivity	Low		Medium	High	
Impact Significance	Negligible	Minor	Moderate	Major	
	Significance of impact is considered <b>negligible</b> .				

Figure 6.22 NOx Isopleths - 1 Hourly Maximum Ground Level Concentrations (NBBL and BPDB Operations with Natural Gas as Fuel)

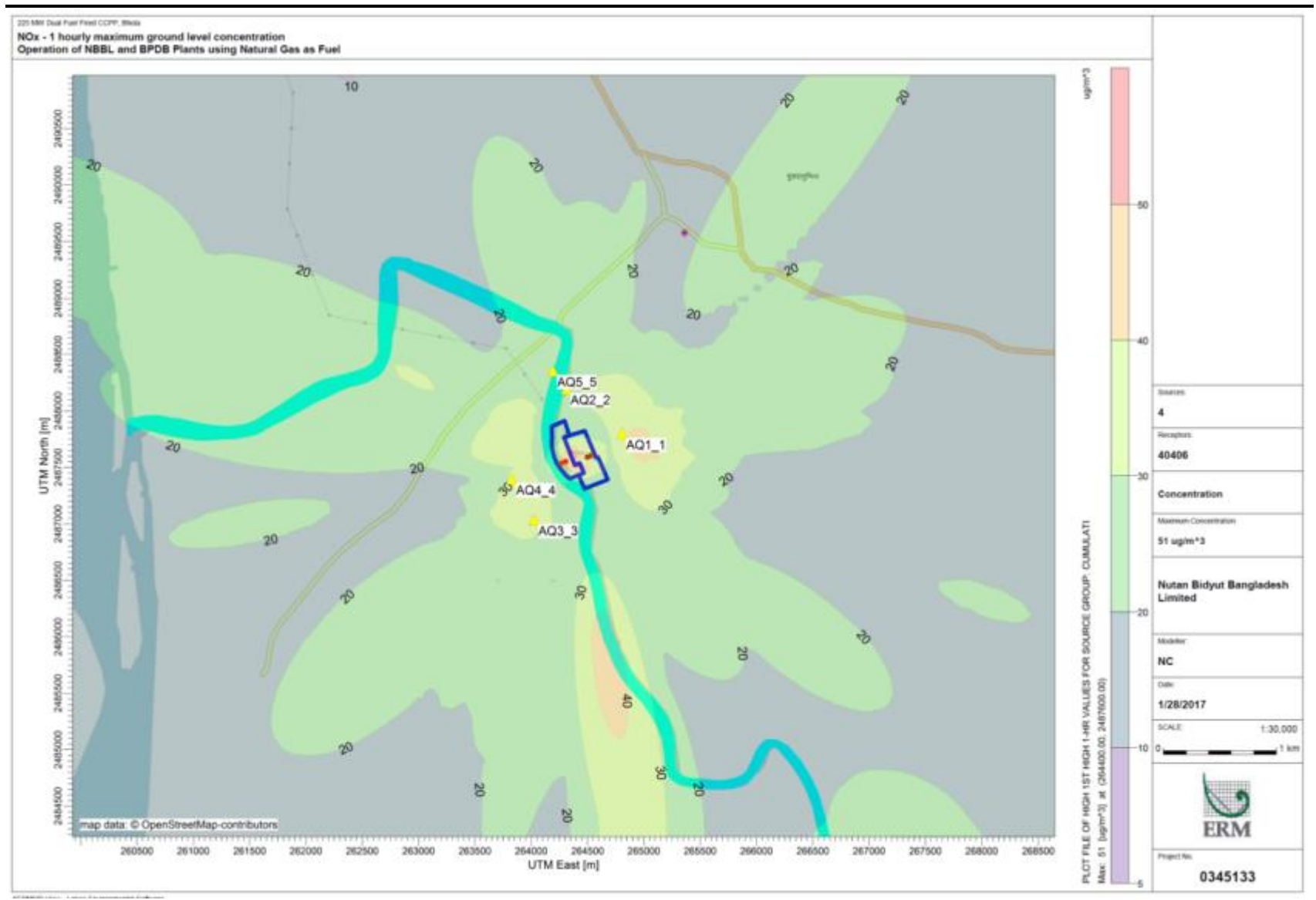


Figure 6.23 NOx Isopleths - 1 Hourly Maximum Ground Level Concentrations (NBBL Operation with HSD as Fuel and BPDB Operation with Natural Gas as Fuel)

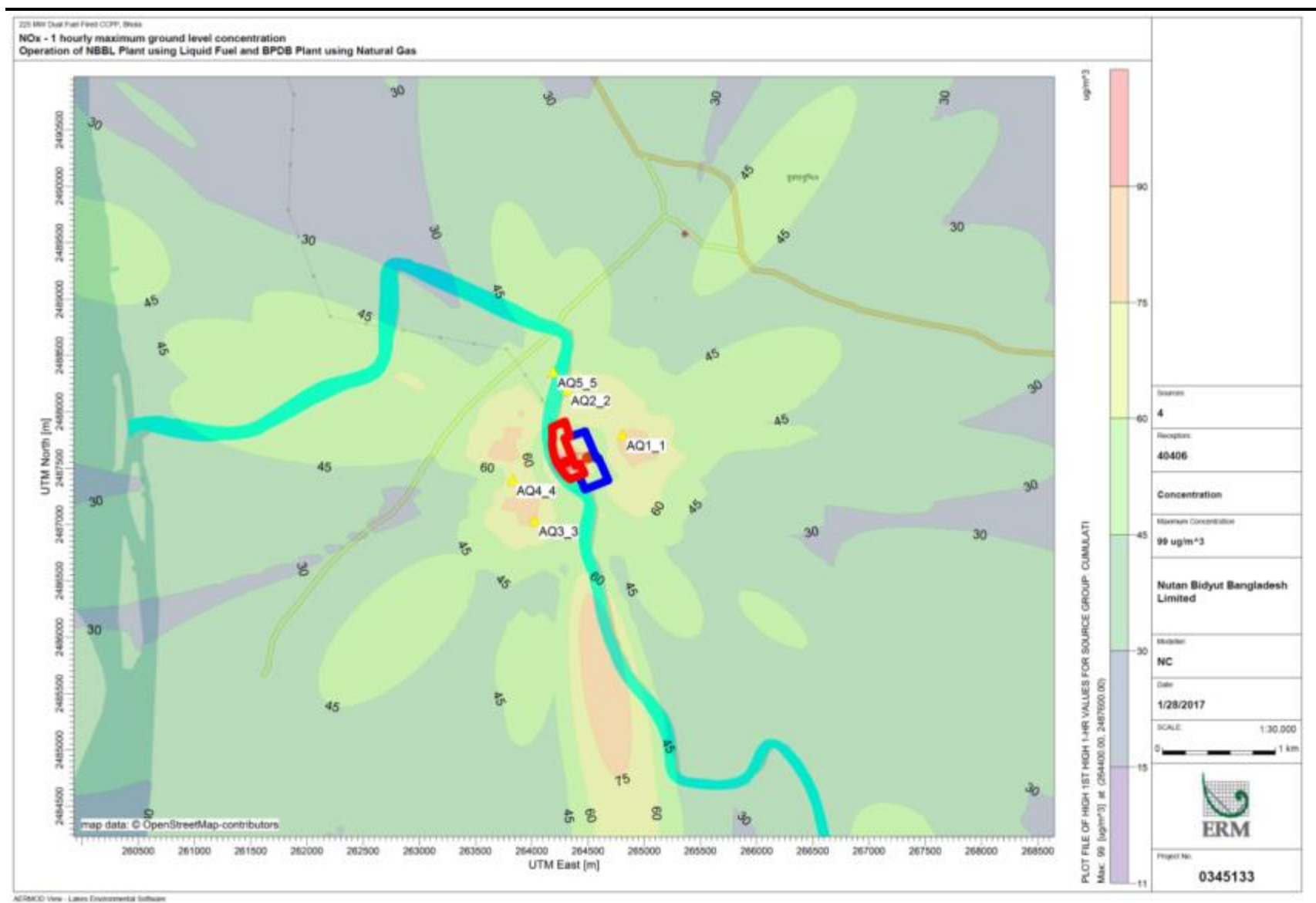




Figure 6.24 NOx Isopleths - 24 Hourly Maximum Ground Level Concentrations (NBBL and BPDB Operations with Natural Gas as Fuel)

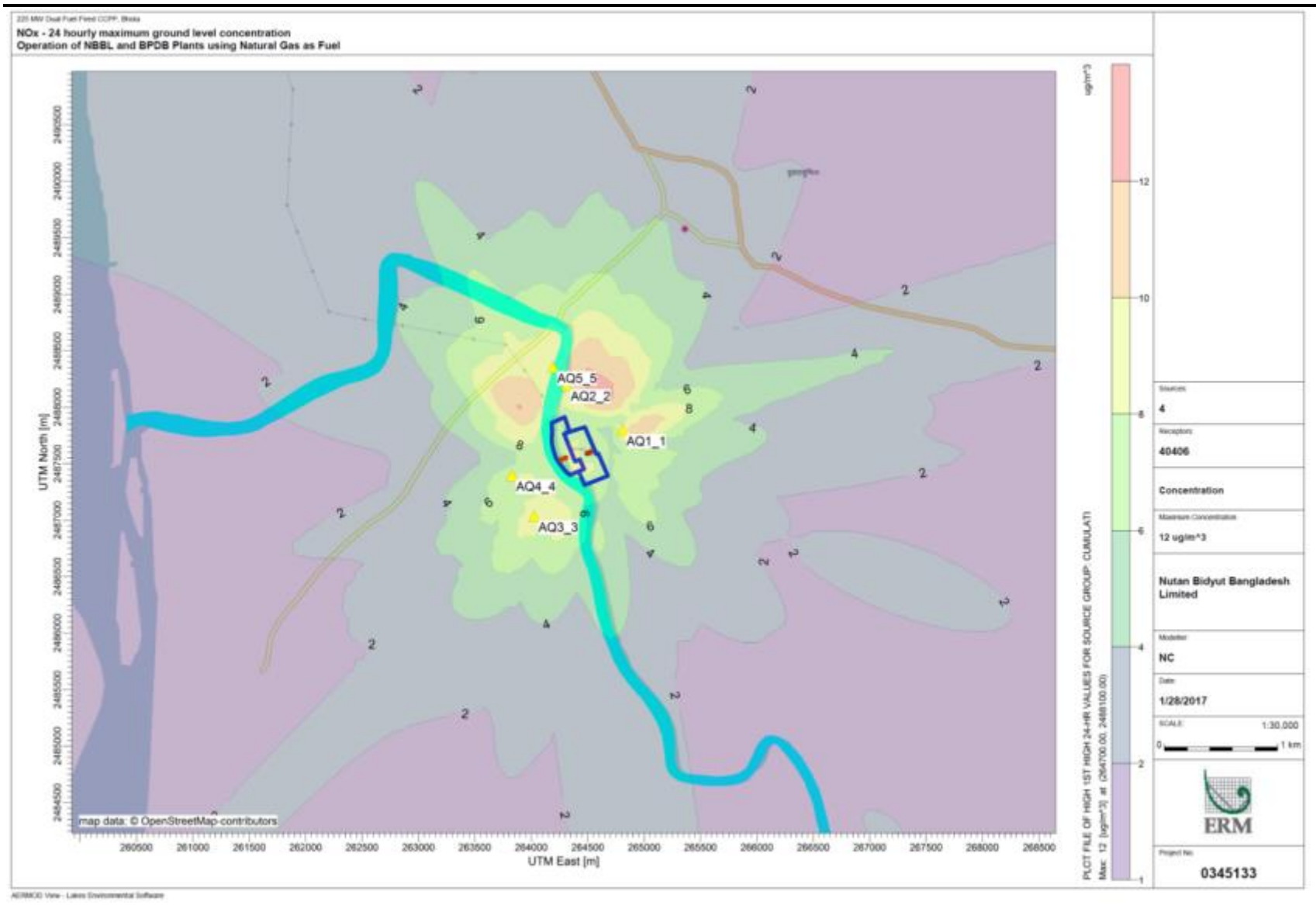


Figure 6.25 NOx Isopleths - 24 Hourly Maximum Ground Level Concentrations (NBBL Operation with HSD as Fuel and BPDB Operation with Natural Gas as Fuel)

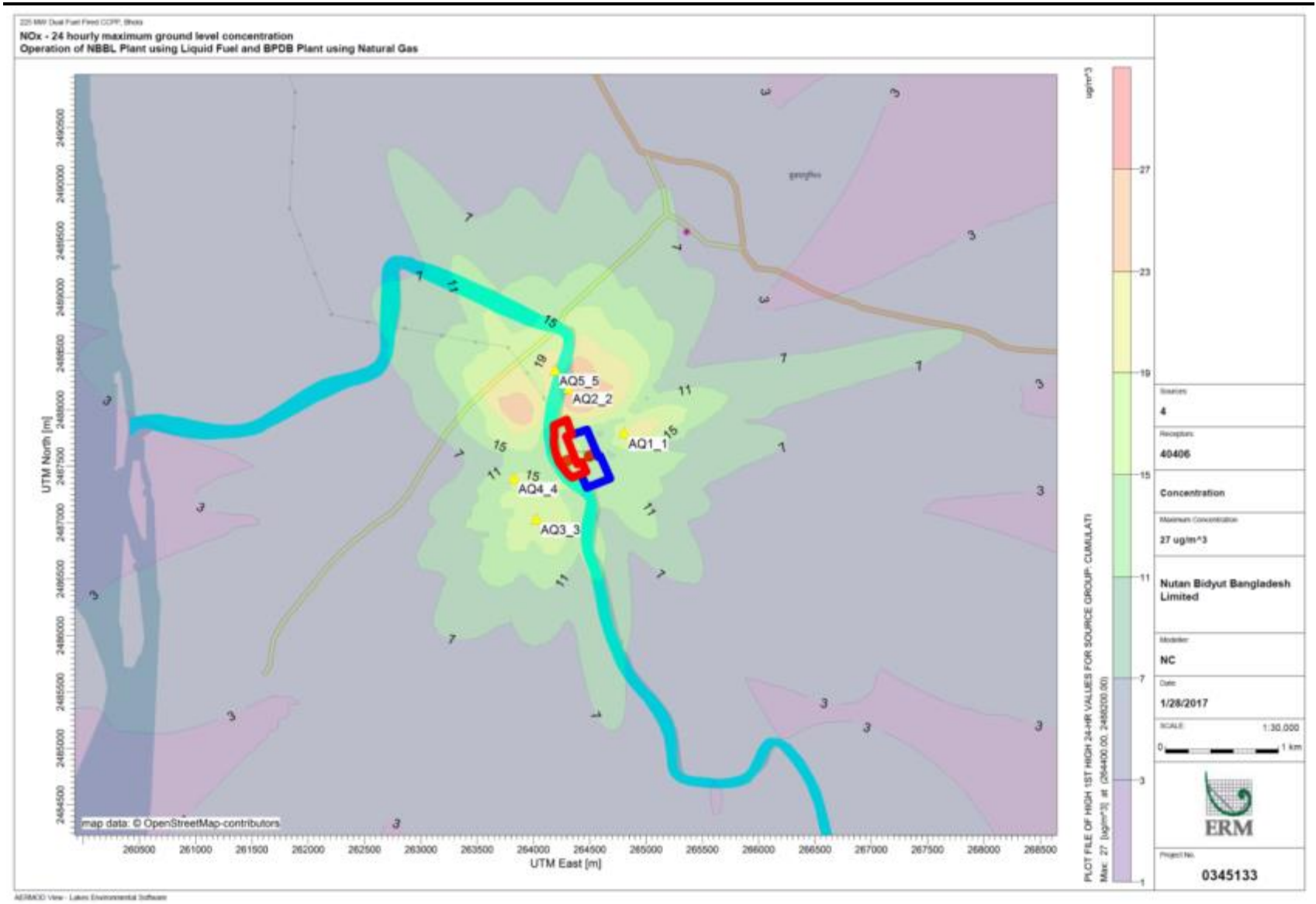




Figure 6.26 NOx Isopleths – Annual Average Ground Level Concentrations (NBBL and BPDB Operations with Natural Gas as Fuel)

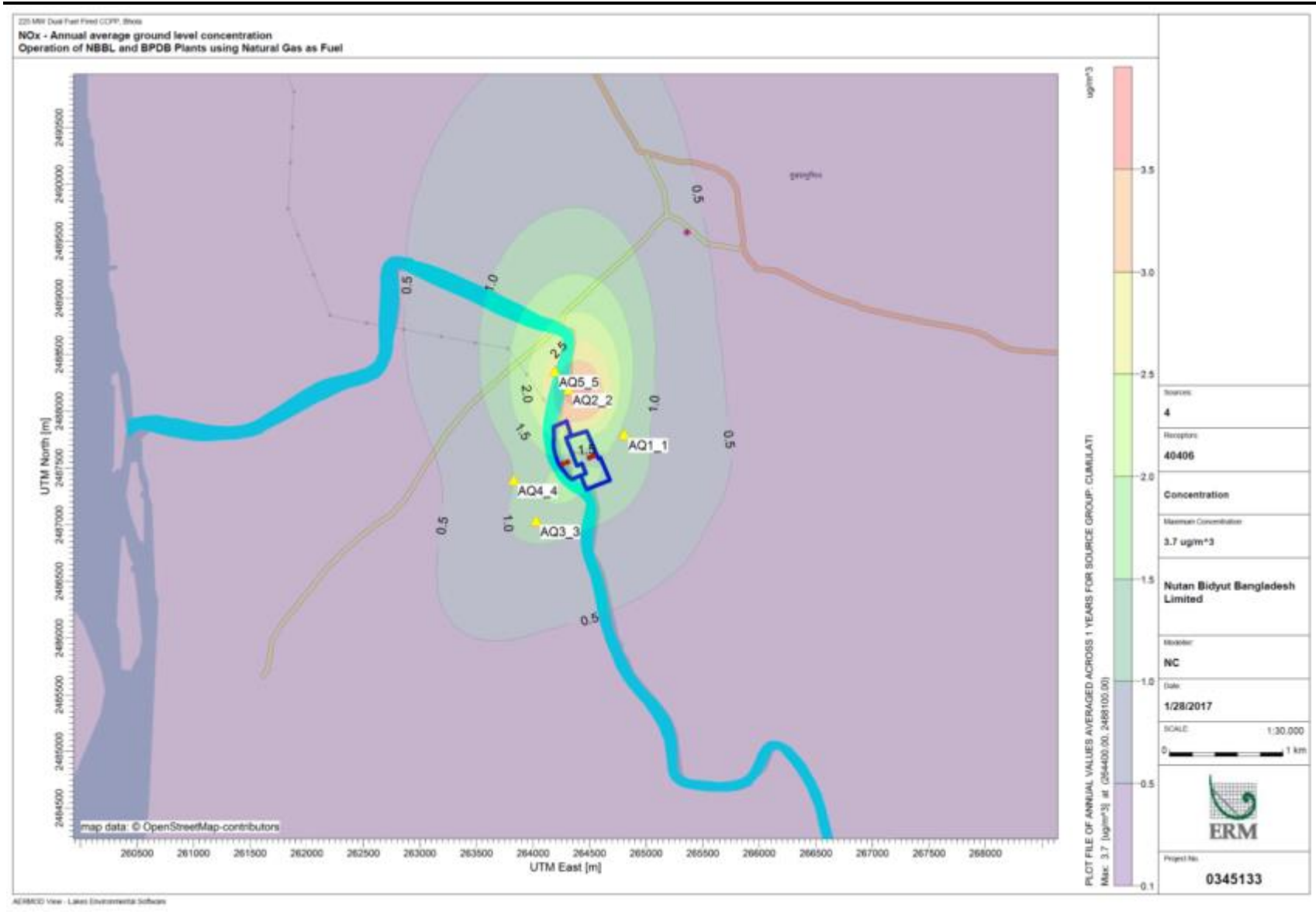


Figure 6.27 NOx Isopleths – Annual Average Ground Level Concentrations (NBBL Operation with HSD as Fuel and BPDB Operation with Natural Gas as Fuel)

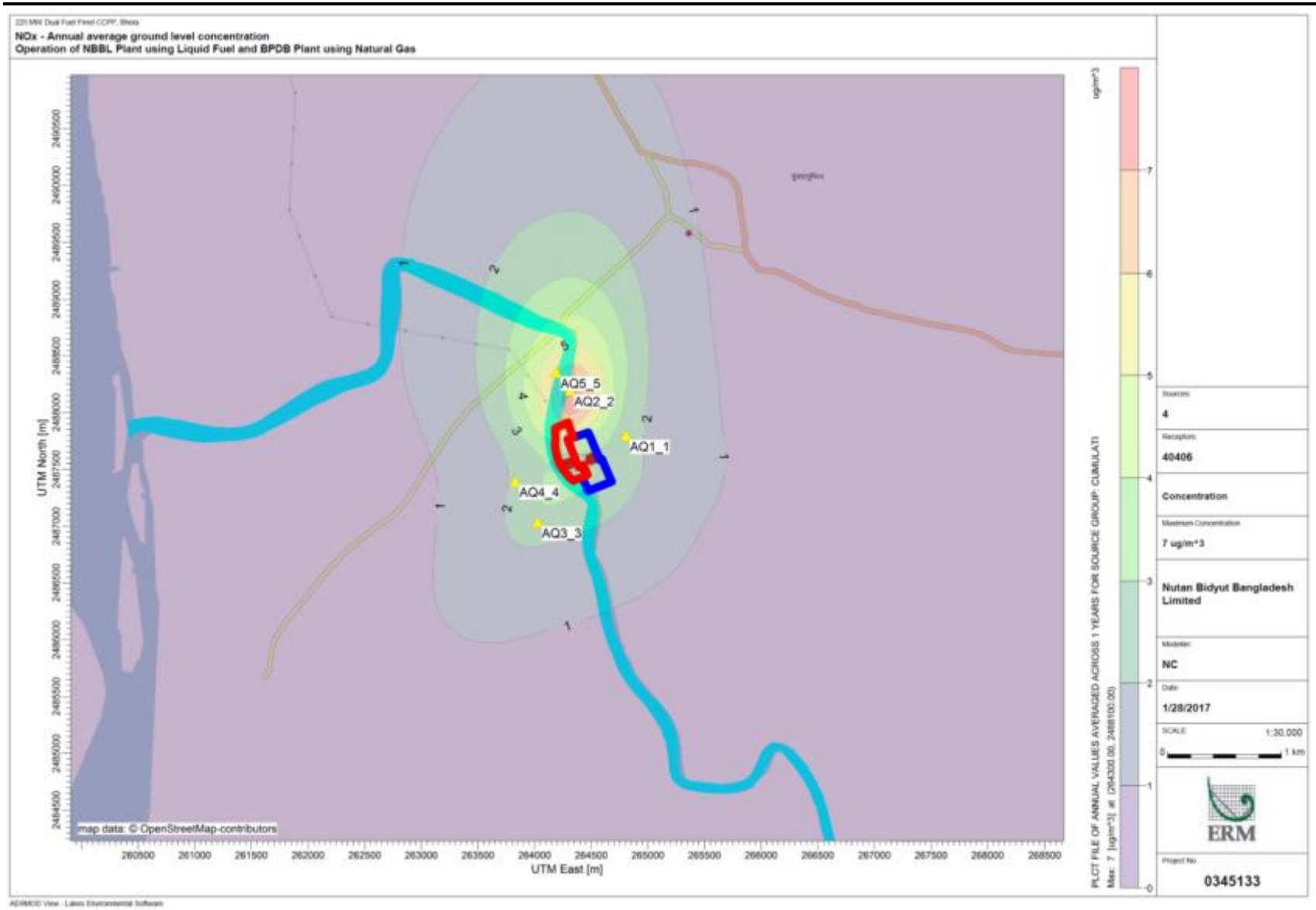


Figure 6.28 SO<sub>2</sub> Isopleths - 24 Hourly Maximum Ground Level Concentrations (NBBL Operation with HSD as Fuel and BPDB Operation with Natural Gas as Fuel)

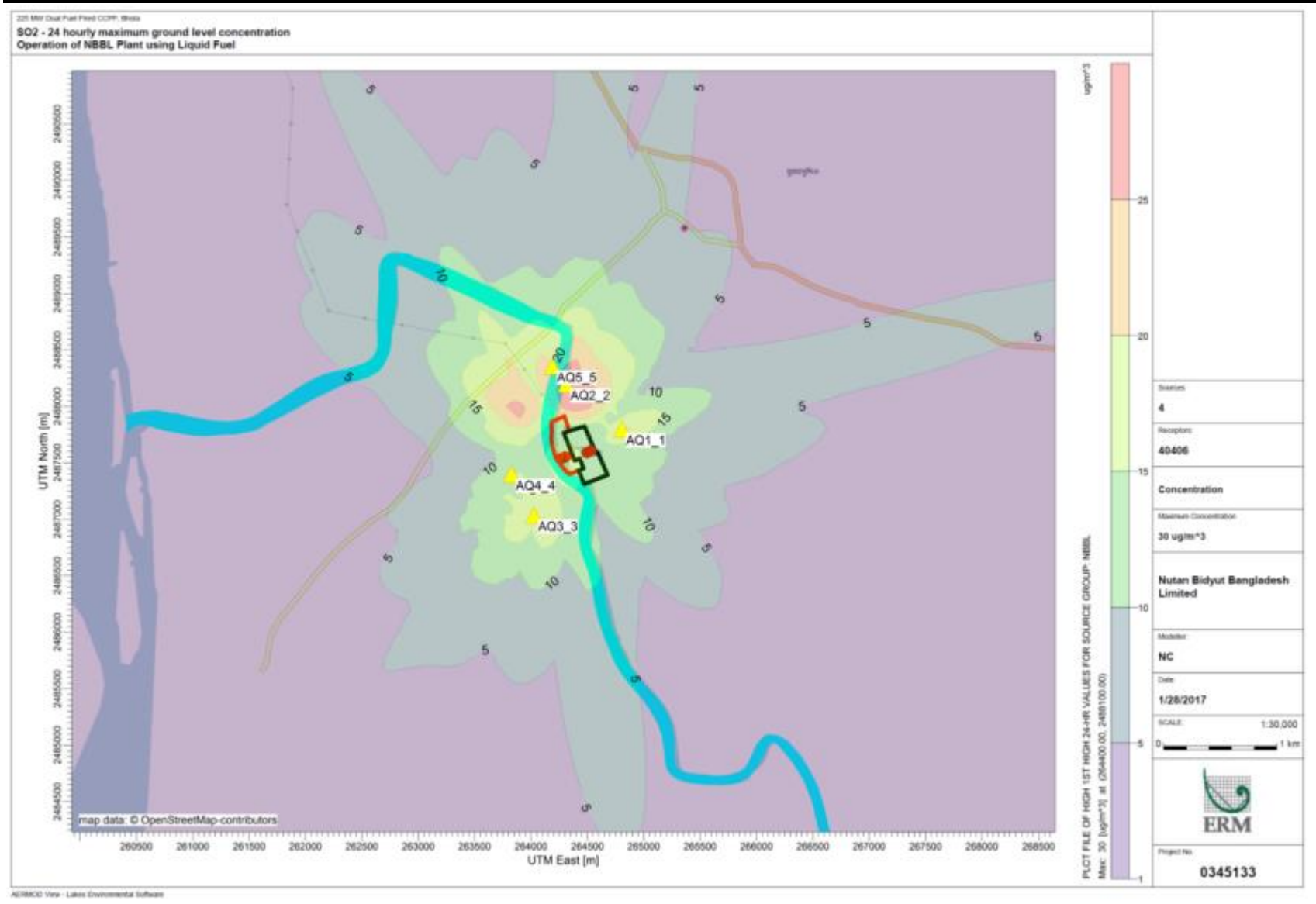


Figure 6.29 SO<sub>2</sub> Isopleths - Annual Average Ground Level Concentrations (NBBL Operation with HSD as Fuel and BPDB Operation with Natural Gas as Fuel)

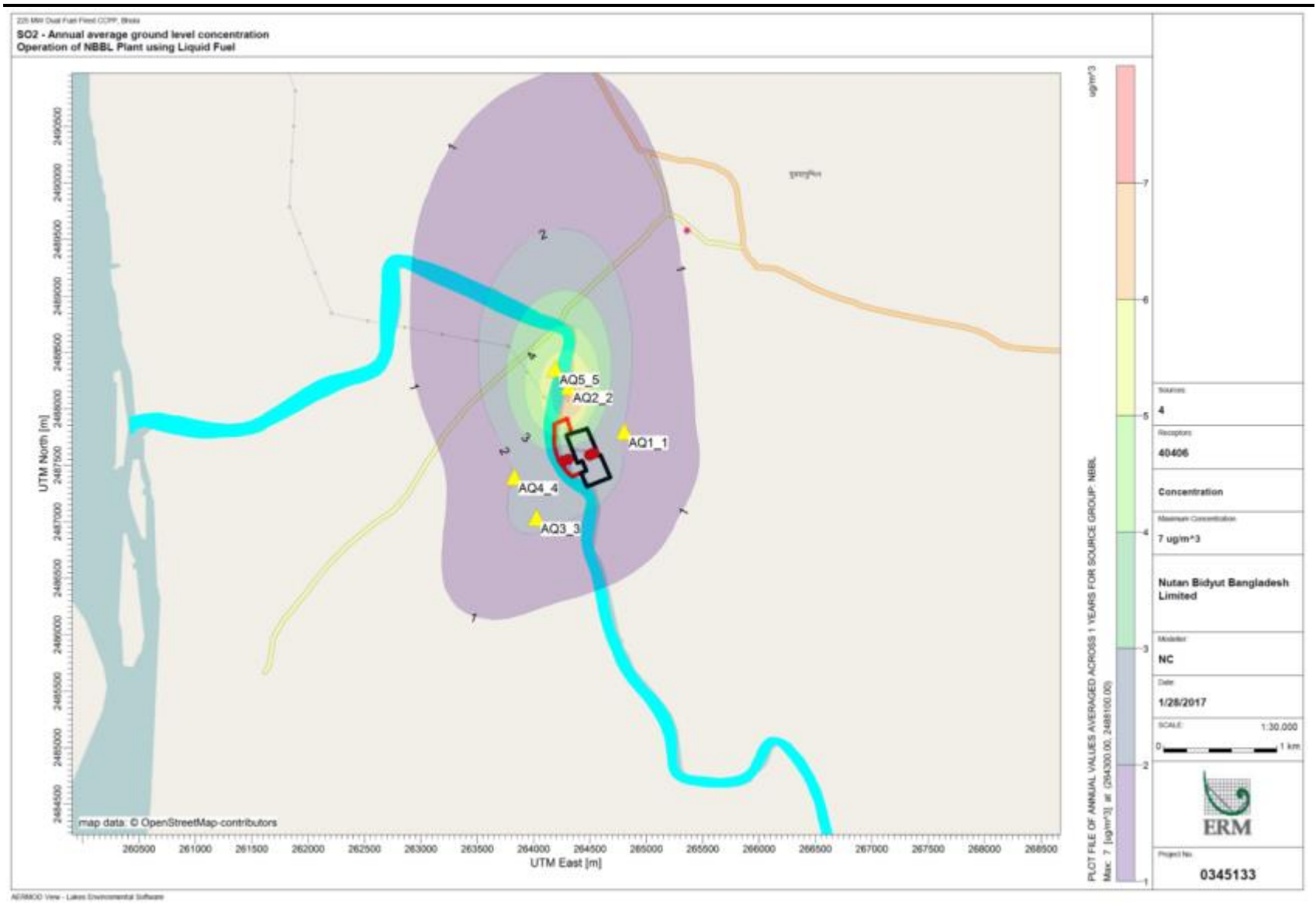




Figure 6.30 *PM<sub>10</sub> Isopleths – 24 hourly Maximum Ground Level Concentrations (NBBL Operation with HSD as Fuel and BPDB Operation with Natural Gas as Fuel)*

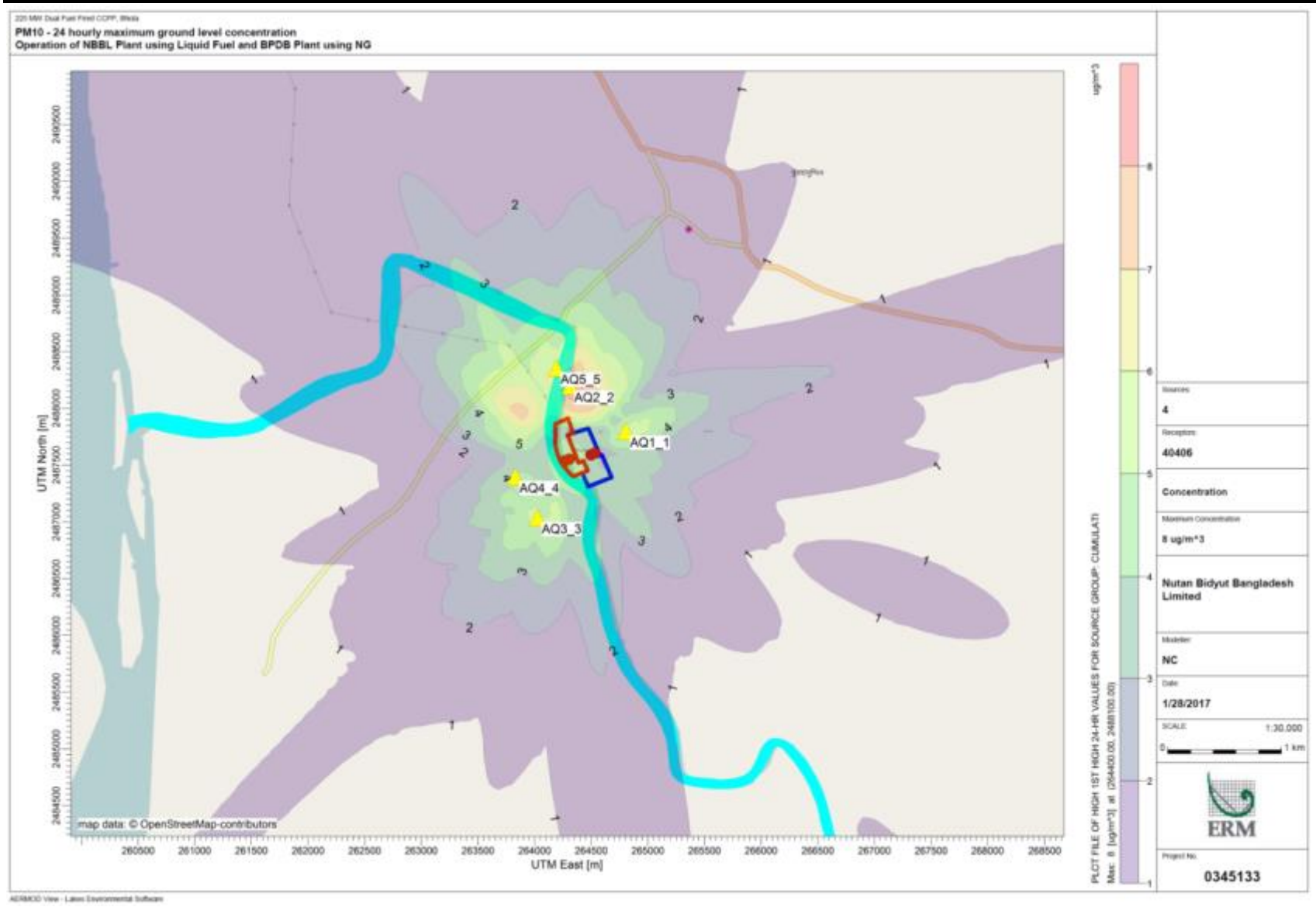
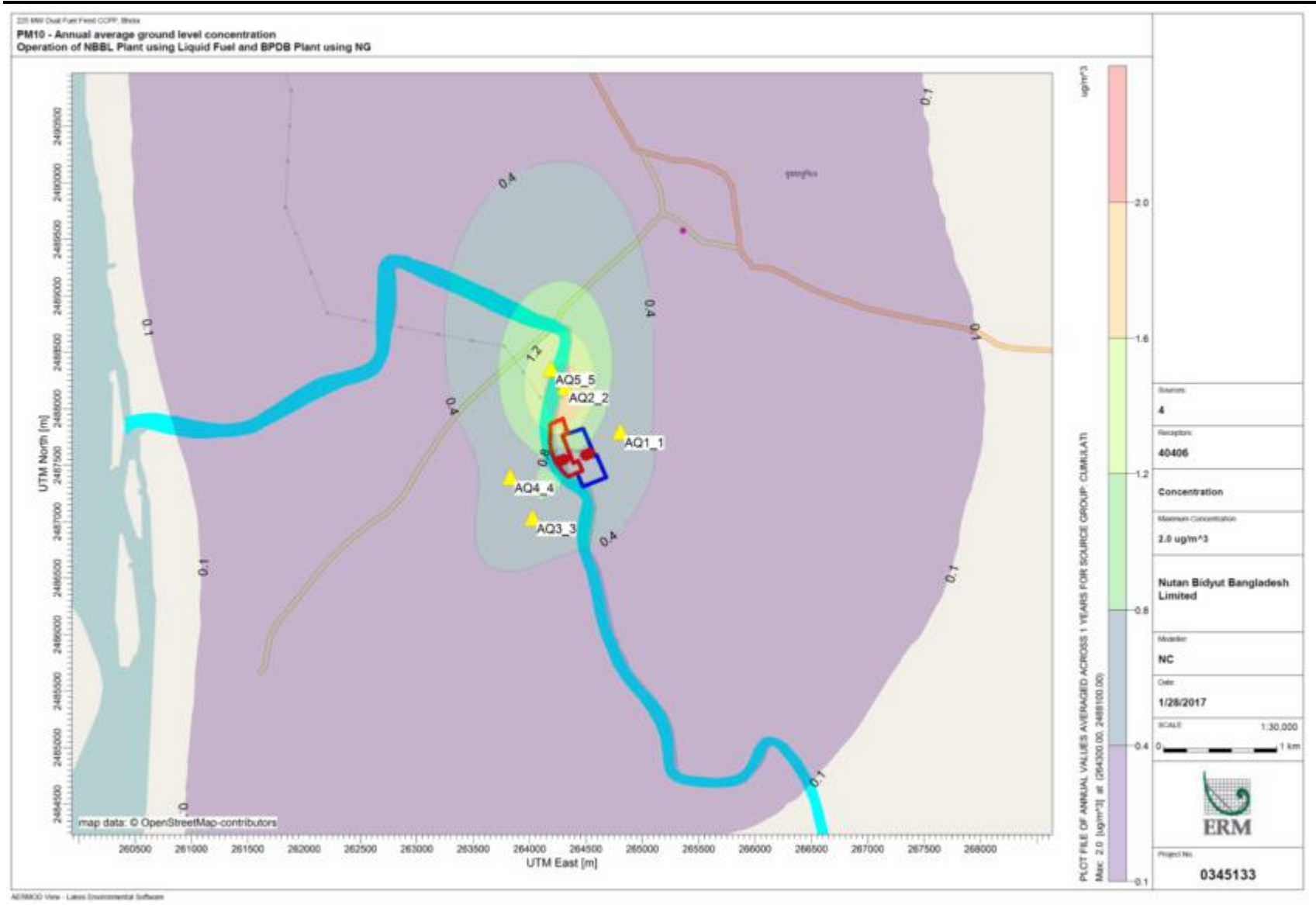


Figure 6.31 *PM<sub>10</sub> Isopleths – Annual Average Ground Level Concentrations (NBBL Operation with HSD as Fuel and BPDB Operation with Natural Gas as Fuel)*



## 6.6.3

*Green House Gases Emissions**Cumulative Impacts due to Operation of Bhola-I and Bhola-II Projects*GHG Estimation and Impact

In order to estimate overall GHG emissions generation from Bhola-I and II projects operation, the IFC recommended Carbon Emission Estimation Tool (CEET model – Version February 2014)<sup>1</sup> has been used as set out below.

**Table 6.32** *Estimated GHG Emissions from the Bhola-I and II Project*

SN	Particular	Unit	Bhola-I	Bhola-II
A*	Net Heat Rate (Natural Gas in Combined Cycle)	KJ/KWH	7,278	7,278
B*	Gross Generation Capacity (Combined Cycle)	KW	225,000	225,000
C	Operating Days	days	330	330
D	Daily Operating Hours	Hours/day	24	24
E	Total Annual Output (= B x C x D)	KWH	1782000000	1782000000
F	Annual Fuel Consumption (= E x A)	KJ	1.29694E+13	1.2969E+13
		TJ	12969.396	12969.396
G**	GHG Emission Rates			
	CO <sub>2</sub>	tCO <sub>2</sub> /TJ	56.1	56.1
	CH <sub>4</sub>	tCO <sub>2</sub> /TJ	0.001	0.001
	N <sub>2</sub> O	tCO <sub>2</sub> /TJ	0.003	0.003
H	<i>Annual GHG Emission in Combined Cycle</i>	<i>tCO<sub>2</sub>e/year</i>	<i>739,917</i>	<i>739,917</i>
I	<b>Gross GHG Emission from Bhola-I and II Plants operation in Combined Cycle Mode</b>	<b>tCO<sub>2</sub>e/year</b>		<b>1,479,834</b>

\* Based on natural gas specification provided by NBBL (refer to Table 3.2 for details) and Gross Generation Capacity of Bhola-I Power Plant.

\*\* Based on GHG emission factors provided in CEET

As per the latest report (26 December 2012) of GHG emission submitted by Bangladesh to the United Nations Framework Convention on Climate Change (UNFCCC)<sup>2</sup>, electricity generation sector contribution to GHG emission in year 2005 was  $1.192 \times 10^7$  tons CO<sub>2</sub>e and projection of aggregate GHG emissions using LEAP modelling program indicates that the annual GHG emissions from this sector in year 2020 and 2030 will be  $2.752 \times 10^7$  tons CO<sub>2</sub>e and  $5.9168 \times 10^7$  tons CO<sub>2</sub>e, respectively. Taking this into consideration, GHG emission contribution of the Power Generation Complex (with total power

<sup>1</sup>

[http://www.ifc.org/wps/wcm/connect/Topics\\_Ext\\_Content/IFC\\_External\\_Corporate\\_Site/CB\\_Home/Measuring+Reporting/](http://www.ifc.org/wps/wcm/connect/Topics_Ext_Content/IFC_External_Corporate_Site/CB_Home/Measuring+Reporting/)

<sup>2</sup> <http://unfccc.int/resource/docs/nat/bgdnc2.pdf>

generation capacity of about 450 MW) in the year 2020 will be 5.38% of the electricity generation sector in Bangladesh. Considering this fact, the GHG emission impact will be **moderate**.

Impact	GHG emissions due to Operation of Bhola-I and Bhola-II Projects				
Impact Nature	Negative	Positive	Neutral		
Impact Type	Direct	Indirect	Induced		
Impact Duration	Temporary	Short-term	Long-term	Permanent	
Impact Extent	Local	Regional	National		
Impact Scale	Impact zone will be regional/ national				
Frequency	Operation Phase				
Likelihood	likely				
Impact Magnitude	Positive	Negligible	Small	Medium	Large
Impact Significance	Negligible	Minor	Moderate	Major	
	Significance of impact is considered <b>moderate</b> .				

### Mitigation Measures

The following mitigation measures will minimise GHG emissions to ALARP levels:

- Ensure that all equipment and machinery is maintained in accordance with manufacturer's specifications;
- Higher efficiency steam turbine blade design; and
- Improved efficiency of auxiliary drives.
- Actual annual GHG emissions from all the plants within the complex shall be compiled and reported by the project owners of Bhola-I and Bhola-II projects.

## 6.6.4 Noise

### Cumulative Noise Impacts

Impact on ambient noise levels due to the operation of Bhola-I and Bhola-II projects were also evaluated by using noise prediction model.

### Criteria

It is planned that the Project will meet the noise emission criteria specified in the GOB ECR, 1997 and the WB/IFC EHS Guidelines, as presented in Table 2.11. Furthermore, for the assessment of ambient noise, the sensitivity and magnitude criteria outlined in Table 6.14 and Table 6.15, respectively have been used:

### Receptors

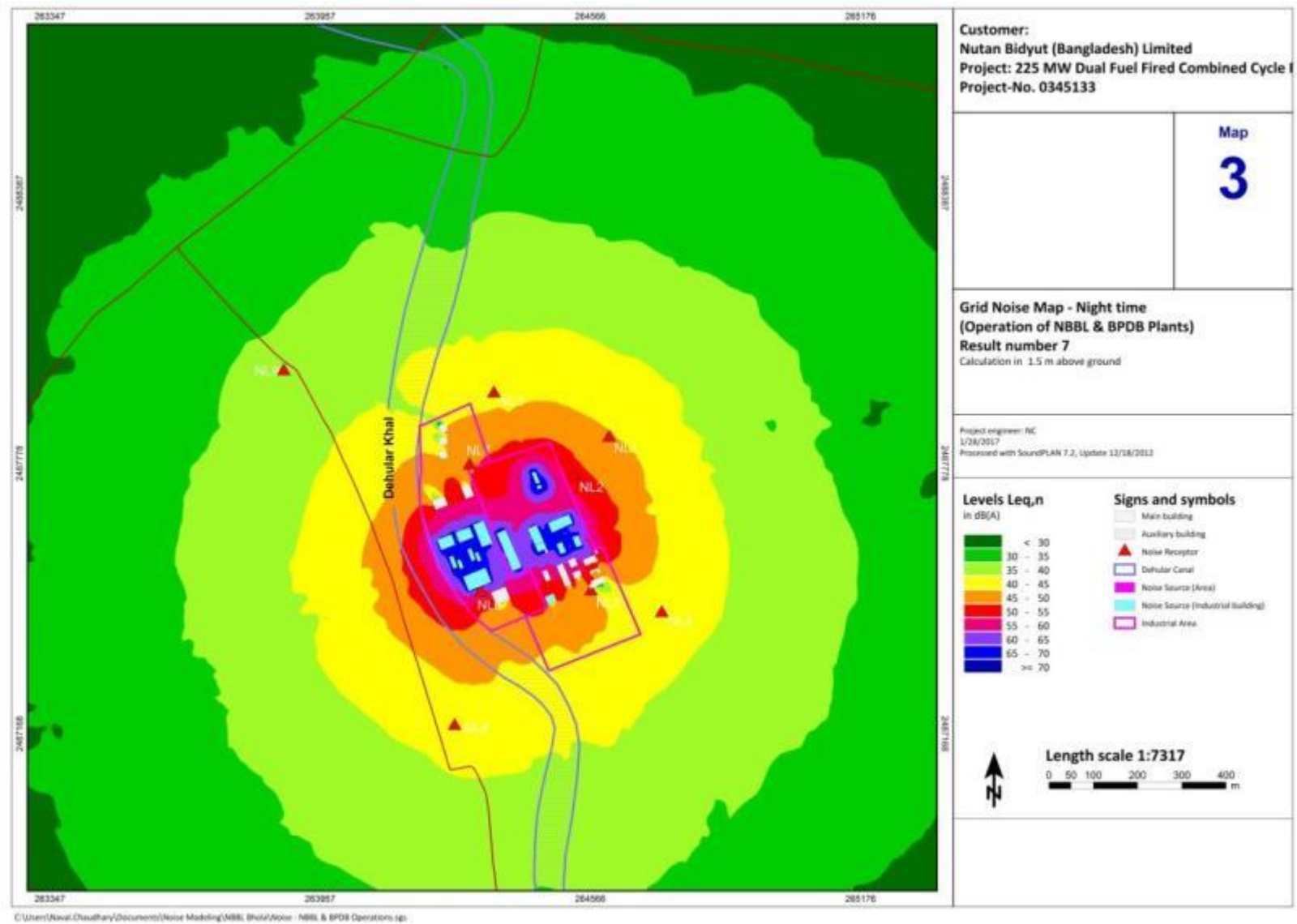
Baseline noise monitoring was carried out at nine locations. The results of baseline monitoring indicated that ambient noise levels at residential areas were high compared to the applicable standards. The nearest receptor is located at 60 m from the Project boundary, which will be exposed to noise from construction activities. Apart from this the settlements located close to

the access road will also be affected due to the movement of vehicles. As can be referred from Table 6.14 and above discussion, the receptors as well as the ecological receptors were assessed to be of Low sensitivity, whereas the human settlements in the surrounding areas (residential areas) were assessed to be of Medium sensitivity.

**Methodology:** The environmental noise prediction model SoundPLAN 7.2 was used for modelling noise emissions from the use of power plant equipment. It has been assumed that all the plant equipment of Bhola-I and II projects will adhere the equipment noise emission criteria of 85 dB(A) noise levels at a distance of 1 m from the source. Major plant components with higher noise generation considered in this study include GTG, STG, HRSG, Auxiliary Boiler, Cooling Tower, CW Pump House, Emergency DG, Water Treatment Facility, Pump House, RMS, and Gas Booster and Conditioning Station of all the three projects. Operation of equipment with 100% usage scenario was modelled to cover the operation phase of the projects. As a conservative approach to the assessment, atmospheric absorption during sound transmission was not included in the assessment. In addition, to represent a worst-case scenario for the assessment, all equipment were assumed to be operating simultaneously. Attenuation due to already constructed boundary wall of the Power Generation Complex has been considered in the modelling.

**Predicted Noise Levels at Receptors:** The predicted noise levels within the Project AOI during day time are presented in Table 6.33. Predicted noise levels at nine receptors (where baseline noise levels were also monitored, which include four receptors within or just outside the boundary of the complex) have been presented in Figure 6.32.

Figure 6.32 Predicted Operation Phase Noise Levels of Bhola-I and Bhola-II Projects during Night-time ( $Leq_{night}$ )





**Table 6.33 Predicted Noise Levels at Noise Receptors during Operation Phase of Bhola-I and Bhola-II Projects**

Receptor Code	Approximate Distance to Power complex Boundary (m) and Direction from Project Site	Baseline Sound Pressure Levels at Receptors, Leq (dBA) <sup>(1)</sup>		Predicted Sound Pressure Levels at Receptors, Leq (dBA)		Total Sound Pressure Level (Baseline + Predicted), Leq (dBA)		Applicable Standard (dB(A)) <sup>(2)</sup> <sup>(3)</sup> as per Landuse	
		Leq <sub>d</sub> <sup>*</sup>	Leq <sub>n</sub> <sup>*</sup>	Leq <sub>d</sub>	Leq <sub>n</sub>	Leq <sub>d</sub>	Leq <sub>n</sub>	Leq <sub>d</sub>	Leq <sub>n</sub>
NL1	130 (E)	53.5	51.0	45.3	45.3	54.1	52.0	55	45
NL2	Complex boundary	65.4	66.1	51.9	51.9	65.6	66.3	70	70
NL3	10 (N)	62.1	54.4	43.3	43.3	62.2	54.7	55	45
NL4	60 (E)	58.3	53.0	42.2	42.2	58.4	53.3	55	45
NL5	within complex	56.9	53.0	46.9	46.9	57.3	54.0	70	70
NL6	within complex	46.3	46.0	59.6	59.6	59.8	59.8	70	70
NL7	within complex	64.8	63.2	48.0	48.0	64.9	63.3	70	70
NL8	230 (SW)	56.8	49.0	42.0	42.0	56.9	49.8	55	45
NL9	340 (NW)	53.9	49.4	36.1	36.1	54.0	49.6	55	45

<sup>(1)</sup> Ambient noise levels as monitored during the baseline survey

<sup>(2)</sup> Environmental Conservation Rules, 1997 (Schedule 4) amended September 7, 2006

<sup>(3)</sup> <sup>(4)</sup> All operations have been considered as continuous and hence there is no change in the day and night time prediction results.

Note: the Bhola-I plant was though operational during the baseline monitoring, however was running with less than 50% load and therefore, to assess the cumulative impacts in worst case scenario, it is assumed that Bhola-I plant was not functional during the baseline monitoring and model predictions for Bhola-I plant also taken into consideration.

It is evident from Table 6.33 that ambient noise levels due to operation of both projects will be well within the applicable standard during day time at 6 receptors and night time at 4 receptors, out of total 9 receptors considered in the study. All the exceedances are due to already higher baseline noise levels during day and night time, whereas predicted noise levels were found to be meeting applicable standards with respect to land use criteria. The cumulative noise impact from NBBL operation during day time is expected to be **negligible to minor**. Furthermore, noise levels at night time will be slightly higher than the applicable standard (with < 5 dBA increase from the applicable standard) at 6 locations. Due to this the cumulative noise impact during night time is expected to be **minor to moderate**.

Impact	<i>Cumulative noise from Operation of Plants (Daytime)</i>				
Impact Nature	Negative	Positive		Neutral	
Impact Type	Direct	Indirect		Induced	
Impact Duration	Temporary	Short-term	Long-term	Permanent	
Impact Extent	Local	Regional		International	
Impact Scale	Maximum impact zone within 100 m from project boundary				
Impact Magnitude	Positive	Negligible	Small	Medium	Large
Resource/ Receptor Sensitivity	Low	Medium		High	
Impact Significance	Negligible	Minor	Moderate	Major	
	Significance of impact is considered <b>negligible to minor</b> .				

Impact	<i>Cumulative Noise from Operation of Plants (Night time)</i>				
Impact Nature	Negative	Positive		Neutral	
Impact Type	Direct	Indirect		Induced	
Impact Duration	Temporary	Short-term	Long-term	Permanent	
Impact Extent	Local	Regional		International	
Impact Scale	Maximum impact zone within 100 m from project boundary				
Impact Magnitude	Positive	Negligible	Small	Medium	Large
Resource/ Receptor Sensitivity	Low	Medium		High	
Impact Significance	Negligible	Minor	Moderate	Major	
	Significance of impact is considered <b>minor to moderate</b> .				

### Mitigation Measures

- Installation of vibration isolation for mechanical noise control;
- The current assessment of cumulative noise impact due to the projects operation is based on mathematical modelling. Once both the plants are operational, periodic ambient noise monitoring is suggested as part of the EMP to monitor the noise levels. This will be done to ensure compliance with the specification and guaranteed performance at noise generating sources as well as ambient noise levels at the receptors located in the surroundings.

- Review of noise guarantees and supporting data of all equipment suppliers with interim noise reports from EPC contractor/s in order to demonstrate compliance with the applicable noise emission criteria at source/s. In case of exceedence from the specified noise limits, adequate corrective actions as may be required shall be implemented by the specific project.

Criterion	Rating pre mitigation	Rating post mitigation	Comment
<b>Change in Ambient Noise Levels during day time</b>			
Residual Impact	Minor	Negligible	With implementation of the mitigation measures mentioned for minimizing the noise generation at source and providing barriers wherever feasible, the night time noise residual impacts would be negligible.
<b>Change in Ambient Noise Levels during night time</b>			
Residual Impact	Minor to Moderate	Negligible to Minor	With implementation of the mitigation measures mentioned for minimizing the noise generation at source and providing barriers wherever feasible, the night time noise residual impacts would be negligible to minor.

The Environment and Social Management Plan (ESMP) for the Project has been developed with an aim to avoid, reduce, mitigate, or compensate for adverse environmental and social impacts/risks and to propose enhancement measures. This includes:

- mitigation of potentially adverse impacts;
- monitoring of impacts and mitigation measures during different Project phases of implementation and operation;
- integration of the ESMP with Project planning, design, construction and operation;
- institutional capacity building and training; and
- Compliance to statutory requirements.

It is to be noted that environmental and social sustainability is embedded in the Project Sponsor's (SP Infra) business decisions and processes through a Group level EHS Management System. NBBL will also align with the requirements of the corporate policies and procedures and ensure that the environmental and social performance of the project is implemented concurrently.

## 7.1

### *MITIGATION MEASURES*

Key environmental and social impacts have been identified and reported in *Chapter 5* along with mitigation measures. A summary of mitigation measures for environmental and ecological receptors is identified for the construction<sup>1</sup> and an operation phase of the Project is presented in *Table 7.1*. *Table 7.2* includes an overview of the socio-economic impacts, mitigation and monitoring measures. This also identifies lead responsibility for implementing the mitigation measures and sources of funds for such implementation. Many of the mitigation measures suggested during the construction phase of the Project are associated with good construction and housekeeping practices and will need to be included within the bid document and final contract agreement with the EPC and equipment contractors. Most of the mitigation measures for the operation phase (such as those for air emissions and noise generation) of the Project are already incorporated into the Project design specifications as embedded control measures.

The construction phase of the Project is anticipated to last approximately 24 months, whereas the operation phase of the Project is 22 years, as per the Power Purchase Agreement (to be signed between NBBL and the BPDB).

(1) <sup>1</sup> Social impacts associated with the planning phase of the Project have also been covered under the construction phase.

However, the design life of the Project is 30 years and NBBL will be responsible for ensuring that the mitigation measures in the ESMP are implemented throughout the life span of the Project.

The ESMP is supported with the following framework management plans (Annex X):

- Annex X1: Stakeholder Engagement Plan;
- Annex X2: Resettlement Framework;
- Annex X3: Gender Action Plan;
- Annex X4: Labour and Influx Management Plan.

Table 7.1 Environmental and Ecological Management Plan of the Project

S. No.	Affected Aspect	Project Activity /affected area	Potential Impacts	Proposed Mitigation Measures	Responsibility for Mitigation Implementation	Responsibility for supervision of mitigation implementation	Reporting Requirements	Approximate cost and Mitigation Cost Source
<b>A Environmental Issues Associated with Site Preparation and Construction</b>								
1.1	Soil Quality	Site clearing, sand filling and site preparation, Laying of gas pipeline, use of heavy loaders from the temporary jetty site	Soil erosion and compaction	<ul style="list-style-type: none"> <li>Demarcation of routes for movement of heavy vehicles especially near the temporary jetty;</li> <li>Stripping and placing soils when dry, and not when wet;</li> <li>Building small bunds in areas with slope to prevent soil erosion.</li> </ul>	Appointed EPC Contractor	On site Project Management team of NBBL	Route plans submitted to HSE and Project Management team of NBBL	<ul style="list-style-type: none"> <li>EPC Contractor Cost</li> </ul>
1.2	Soil and sediment Quality	<ul style="list-style-type: none"> <li>Fuelling and operation of heavy machinery and transport vehicles, Unloading and loading activities near the temporary jetty</li> <li>Storage and handling of chemicals</li> </ul>	Soil and sediment contamination through spills and leaks	<ul style="list-style-type: none"> <li>Fuel tanks and chemical storage areas to be sited on sealed areas and provided with locks to prevent unauthorized entry;</li> <li>Preparation of guidelines and procedures for immediate clean-up actions following any spillages of oil, fuel or chemicals;</li> <li>Development of a site specific Emergency Response Plan for soil clean-up and decontamination;</li> <li>Implementation of a training program to familiarise staff and workers with emergency procedures and practices related to contamination events;</li> <li>Storage areas for oil, fuel and chemicals to be surrounded by bunds or other containment devices to prevent any spilled oil, fuel or chemicals from contaminating soils, sediment, water or groundwater;</li> <li>Use of spill or drip trays to contain spills and leaks, and use of spill control kits to clean small spills and leaks; and</li> <li>Installation of oil/water separators to treat surface run-off from bunded areas prior to discharge to the storm water system.</li> </ul>	Appointed EPC Contractor	HSE Team of NBBL and on site Project Management team	Plans submitted to HSE Team for approval and monthly reports to NBBL	<ul style="list-style-type: none"> <li>EPC Contractor Cost</li> </ul>
1.3	Soil Quality	Storage, handling and disposal of construction waste	Soil contamination	<ul style="list-style-type: none"> <li>Training labourers for waste disposal in designated areas and use of sanitation facilities;</li> <li>Provide dedicated storage areas for construction materials to minimise the potential for damage or contamination of the materials;</li> <li>Implement a construction materials inventory management system to minimise over-supply of the construction materials, which may lead to disposal of the surplus materials at the end of the construction period;</li> <li>Segregate hazardous and non-hazardous waste and provide appropriate containers for the waste types generated (e.g. enclosed bins for putrescible materials to avoid attracting pests and vermin and to minimise odour nuisance);</li> <li>Store wastes in closed containers away from direct sunlight, wind and rain;</li> <li>Provide enough space to allow for inspection between waste containers so as to identify any leaks or spills;</li> <li>Ensure storage areas have impermeable floor and containment, of capacity to accommodate 110% of the volume of the largest waste container;</li> <li>Storage of inert concrete waste in a laydown area near the concrete batching plant and reuse of these wastes under floors or roads; and</li> <li>Dispose of hazardous waste including bitumen by licensed contractors.</li> </ul>	Appointed EPC Contractor	HSE Team of NBBL and on site Project Management team	Monthly report to NBBL	<ul style="list-style-type: none"> <li>EPC Contractor Cost</li> </ul>

S. No.	Affected Aspect	Project Activity /affected area	Potential Impacts	Proposed Mitigation Measures	Responsibility for Mitigation Implementation	Responsibility for supervision of mitigation implementation	Reporting Requirements	Approximate cost and Mitigation Cost Source
2.1	Surface Water Quality	<ul style="list-style-type: none"> <li>Wastewater Discharge from washing of equipment and machinery</li> <li>Sanitary facilities</li> </ul>	Surface water contamination	<ul style="list-style-type: none"> <li>Vehicle servicing areas and wash bays located within roofed and cemented areas. The drainage in these covered areas connected to oil/ water separator and channelized properly to the land/inland waters ;</li> <li>Oil leakage or spillage contained and cleaned up immediately. Waste oil to be collected and stored for recycling or disposal;</li> <li>Oil and grease separator shall be used for wastewater generated from cleaning activities;</li> <li>Any surplus wastewater from the concrete batching to be treated to comply with discharge standards before it is discharged;</li> <li>Adequate sanitary facilities, i.e. toilets and showers, provided for the construction workforce;</li> <li>Workers trained in the use of designated areas/bins for waste disposal and encouraged to use toilets.</li> <li>Septic tanks provided to treat sanitary wastewater; and all sewage and liquid effluent treated to meet the standards specified in Schedules 9 and 10 of the ECR, 1997 respectively and IFC EHS Guidelines prior to discharge to land/inland waters.</li> </ul>	Appointed EPC Contractor	On site Project Management team and designated HSE team	Monthly report to NBBL	<ul style="list-style-type: none"> <li>EPC Contractor Cost</li> </ul>
2.2	Ground Water Quality	<ul style="list-style-type: none"> <li>Leaks and spills of oil, lubricants, fuel</li> <li>Improper handling of sewage or chemical</li> </ul>	Groundwater contamination	<ul style="list-style-type: none"> <li>Implementation of a regular and rigorous watering and sprinkling regime for dust suppression during the dry season;</li> <li>As far as possible, locate the concrete batching plant away from sensitive receptors and additional net fencing/ solid barrier on section of boundary wall facing the residential receptors to reduce dust transport.;</li> <li>Maintain the maximum possible distance between stockpiles and receptors;</li> <li>Cover and/or water spray all stockpiles of dusty materials such as excavated spoils, loose construction material piles to avoid fugitive dust;</li> <li>During construction, the access road will be regularly maintained to keep it clean, free from mud and slurry.</li> <li>Material transport will be totally enclosed with impervious sheeting and wheel washing will be carried out at site.</li> <li>No waste will be burnt on or around the Project site.</li> </ul>	Appointed EPC Contractor	On site Project Management team and designated HSE team	Monthly report to NBBL	<ul style="list-style-type: none"> <li>EPC Contractor Cost</li> </ul>
	Air Quality	<ul style="list-style-type: none"> <li>Site preparation, filling and levelling;</li> <li>Excavation of soil for building and equipment foundations;</li> <li>Pile driving for the equipment foundation;</li> <li>Concrete works</li> <li>Transportation related activities</li> </ul>	Dust generation	<ul style="list-style-type: none"> <li>Implementation of a regular and rigorous watering and sprinkling regime for dust suppression during the dry season;</li> <li>As far as possible, locate the concrete batching plant away from sensitive receptors and additional net fencing/ solid barrier on section of boundary wall facing the residential receptors to reduce dust transport.;</li> <li>Maintain the maximum possible distance between stockpiles and receptors;</li> <li>Cover and/or water spray all stockpiles of dusty materials such as excavated spoils, loose construction material piles to avoid fugitive dust;</li> <li>During construction, the access road will be regularly maintained to keep it clean, free from mud and slurry.</li> <li>Material transport will be totally enclosed with impervious sheeting and wheel washing will be carried out at site.</li> <li>No waste will be burnt on or around the Project site.</li> </ul>	Appointed EPC Contractor	On site Project Management team and designated HSE team	Monthly report to NBBL	<ul style="list-style-type: none"> <li>EPC Contractor Cost</li> </ul>
3.2	Air Quality	<ul style="list-style-type: none"> <li>Operation of heavy machinery and transport vehicles</li> <li>Operation of DG sets</li> </ul>	Exhaust Emissions	<ul style="list-style-type: none"> <li>A speed limit of 20 km/hr will be enforced on the construction site/access road;</li> <li>Regularly maintain all diesel-powered equipment and reduce idling time to avoid emissions of NO<sub>x</sub>, PM<sub>10</sub> and SO<sub>2</sub>;</li> <li>Use of high speed diesel (HSD) with sulphur content &lt; 0.25% in HGVs and diesel powered equipment; and</li> <li>Vehicle / equipment exhausts observed to be emitting significant black smoke from their exhausts will be serviced/ replaced.</li> </ul>	Appointed EPC Contractor	On site Project Management team and designated HSE team	Monthly report to NBBL	<ul style="list-style-type: none"> <li>EPC Contractor Cost</li> </ul>
	Noise	<ul style="list-style-type: none"> <li>Heavy machinery operations for construction works</li> <li>Piling for equipment foundation</li> <li>Transportation related activities</li> </ul>	Increase in ambient noise levels	<ul style="list-style-type: none"> <li>Normal working hours of the contractor will be between 06:00 and 21:00 hours from Monday to Sunday. If work needs to be undertaken outside these hours, it should be limited to activities that do not lead to exceedance of the noise criteria at nearby NSRs;</li> <li>Only well-maintained equipment should be operated on-site;</li> <li>Regular maintenance of equipment including lubricating moving parts, tightening loose parts and replacing worn out components should be conducted;</li> <li>The number of equipment operating simultaneously</li> </ul>	Appointed EPC Contractor	On site Project Management team and designated HSE team	Monthly report to NBBL	<ul style="list-style-type: none"> <li>EPC Contractor Cost</li> </ul>



S. No.	Affected Aspect	Project Activity /affected area	Potential Impacts	Proposed Mitigation Measures	Responsibility for Mitigation Implementation	Responsibility for supervision of mitigation implementation	Reporting Requirements	Approximate cost and Mitigation Cost Source
				<p>should be reduced as far as practicable;</p> <ul style="list-style-type: none"> <li>Equipment known to emit noise strongly in one direction should be orientated so that the noise is directed away from nearby NSRs as far as practicable;</li> <li>Noisy plant (such as breakers and rollers) shall be located as far away from receptors as practicable.</li> </ul>				
	Terrestrial Flora and Fauna	<ul style="list-style-type: none"> <li>Site preparation and related activities</li> <li>Excavation for natural gas Pipeline</li> </ul>	<p>Habitat loss due to:</p> <ul style="list-style-type: none"> <li>Clearance of Vegetation at natural gas pipeline</li> <li>Clearance of site before sand filling and levelling</li> </ul>	<ul style="list-style-type: none"> <li>Pre-construction survey for the project site by Herpetofaunal experts is required and clearance of existing scrap material should be done with support of a certified snake catcher for rescue if any species found. Similar arrangement should be made for the pipeline RoW.</li> <li>Pre- construction surveys of bird nest before vegetation removal in the Row of pipeline should be under taken;</li> <li>Land clearing will be kept minimum to the extent practicable for the approach road and gas pipeline;</li> <li>Wherever feasible, changes in the alignment of gas pipeline will be made to avoid felling of larger trees and village ponds.</li> <li>Wherever feasible, depending upon availability of space within plant and/or along the access road, plantation activities shall be performed.</li> <li>Engage with local forest department and Upazilla administration for plantation activities outside the project area.</li> <li>Preference to the local workers will be given in construction activities to avoid pressure on the natural resources;</li> <li>Strict instruction should be given to the construction workers not to cut trees from the nearby areas for their fuel and timber use;</li> <li>Hunting and trapping of wild animals should be prohibited by the work force and should be bounded by contractual obligations;</li> <li>Use of LPG/ Kerosene for cooking need to be provided/ encouraged in order to reduce the impacts on vegetation from the vicinity of the Project site;</li> <li>Construction workers will be given conservation and awareness training to promote sustainable resource use.</li> </ul>	Project Management along with hired specialists and Appointed EPC Contractor	On site Project Management Team including specialist as required	Monthly report to NBBL	<ul style="list-style-type: none"> <li>Project Developer and EPC Contractor Cost</li> </ul>
5.2	Terrestrial/ Aquatic Flora and Fauna	Construction and transportation related activities	<p>Habitat disturbance</p> <ul style="list-style-type: none"> <li>Impact on species of conservational significance</li> </ul>	<ul style="list-style-type: none"> <li>In case of bank erosions due to movement of barges and vessels used during construction and/or operation phases, NBBL shall invest in bank protection at both sides between Kheya Ghat to the project site as the movement of large barges and vessels will create swells and may erode the Khal banks and increase the turbidity in Khal;</li> <li>The ideal time to enter the Khal by vessels should be preferably mid-afternoon as during this time the faunal activity reduces;</li> <li>Pre-construction surveys should be undertaken by a Gharial Expert of the Dehular Khal to ascertain its presence; Any mitigation measures as agreed by NBBL should be implemented during construction phase;</li> <li>A migratory bird survey shall be carried out during winter season to ascertain any impact of project activities on them; and mitigation measures as deemed necessary to be taken up by NBBL.</li> </ul>	Project Management along with hired specialists and Appointed EPC Contractor	On site Project Management Team and Designated HSE team on site including specialist as required	Survey report/s and monthly report to NBBL	<ul style="list-style-type: none"> <li>Project Developer Cost and EPC Contractor Cost</li> </ul>
	Transportation	<ul style="list-style-type: none"> <li>Transportation of personnel and use of road network</li> </ul>	Disturbance to existing road users through increase in road traffic	<ul style="list-style-type: none"> <li>Avoiding peak hours for heavy vehicles movement where possible;</li> <li>Speed limit within access road shall be less than 20</li> </ul>	NBBL and Appointed EPC Contractor	On site Project Management team and designated HSE	Monthly report to NBBL	<ul style="list-style-type: none"> <li>EPC Contractor Cost</li> </ul>

S. No.	Affected Aspect	Project Activity /affected area	Potential Impacts	Proposed Mitigation Measures	Responsibility for Mitigation Implementation	Responsibility for supervision of mitigation implementation	Reporting Requirements	Approximate cost and Mitigation Cost Source
				km/hr; <ul style="list-style-type: none"> <li>Training and awareness amongst driver's to encourage systematic parking, following traffic rules, preventing unnecessary stoppages and overtaking.</li> </ul>		team		
	Community Health and Safety	<ul style="list-style-type: none"> <li>General construction activities</li> <li>Influx of construction workers</li> </ul>	<ul style="list-style-type: none"> <li>Health Impacts due to Changes in environmental conditions</li> <li>Increased prevalence of disease</li> </ul>	<ul style="list-style-type: none"> <li>Barriers will be provided to prevent ingress of persons into the construction site and also to protect public exposure to hazards associated with construction activities;</li> <li>Screening, surveillance and treatment of workers, through the provision of medical facilities and, where required, immunization programmes;</li> <li>Undertaking health awareness and education initiatives among workers;</li> <li>Implementation of a vector control programme in labour camps and surrounding areas;</li> <li>Avoiding formation of stagnant water pools in and around the site;</li> <li>Prevention of larval and adult mosquito propagation through sanitary improvements and elimination of breeding habitats close to human settlements in the close vicinity of Project site;</li> <li>Educating area residents and workers on risks, prevention, and available treatment for vector-borne diseases.</li> </ul>	Appointed EPC Contractor along with Project Management	On site Project Management Team and Designated HSE team on site	Monthly Report to NBBL	<ul style="list-style-type: none"> <li>EPC Contractor Cost</li> </ul>
7.2	Community Health and Safety	Heavy traffic movement	Traffic safety	<ul style="list-style-type: none"> <li>Emphasizing safety aspects among drivers, particularly with regard to the speed limit of 20 km/hr that will be enforced;</li> <li>Ensuring that only licensed drivers are employed by the Project;</li> <li>Avoiding peak hours for heavy vehicles movement where possible;</li> <li>Regular maintenance of vehicles and use of manufacturer approved parts to minimize potentially serious accidents caused by equipment malfunction or premature failure;</li> <li>Collaboration with local communities and responsible authorities to improve signage ( e.g. pedestrian crossings, speed limits etc.), visibility and awareness of traffic and pedestrian safety; and</li> <li>Coordination with emergency responders to ensure that appropriate first aid is provided in the event of accidents.</li> </ul>	Appointed EPC Contractor	On site Project Management Team and Designated HSE team on site	Monthly Report to NBBL	<ul style="list-style-type: none"> <li>EPC Contractor Cost</li> </ul>
7.3	Occupational Health and Safety	Construction activities	<ul style="list-style-type: none"> <li>Risks of accidents and fatalities to workers</li> </ul>	<ul style="list-style-type: none"> <li>Development and implementation of site specific health and safety plan;</li> <li>On job training for the workers shall be carried out;</li> <li>Work permit system shall be followed;</li> <li>PPE shall be provided and use of PPEs shall be enforced;</li> <li>SOPs need to be developed for construction and related activities of the Plant;</li> </ul>	HSE Team of Appointed EPC Contractor and on-site project management team	Designated Team comprising of representation from HSE /HR/ Administration of NBBL	Relevant Records maintained and monthly internal report to senior management.	<ul style="list-style-type: none"> <li>EPC Contractor Cost</li> </ul>
<b>B</b>	<b>Environmental Issues Associated with the Operation Phase</b>							
1.1	Soil and Sediment Quality	Waste generated from <ul style="list-style-type: none"> <li>Office and Canteens;</li> <li>WTP, ETP and STP;</li> <li>Gas Turbines;</li> <li>Laboratories;</li> <li>GT Compressors;</li> <li>Lube oil systems;</li> </ul>	<ul style="list-style-type: none"> <li>Contamination of soil and sediment from wastes</li> </ul>	<ul style="list-style-type: none"> <li>Wastes shall be stored in a manner that will prevent contact between incompatible wastes i.e. post compatibility checks,</li> <li>Proper labelling of hazardous wastes;</li> <li>Special care shall be taken in the storage areas to prevent any spillage of hazardous wastes and restrict access (except for trained staff) to such areas;</li> </ul>	Project Developer/Plant Management/ Plant HSE Team	Designated Team comprising of representation from relevant departments as HSE, Operations, Administration and HR.	Monthly internal reports to top management and reporting to regulatory authorities/lenders as required.	<ul style="list-style-type: none"> <li>Plant O&amp;M Cost</li> </ul>

S. No.	Affected Aspect	Project Activity /affected area	Potential Impacts	Proposed Mitigation Measures	Responsibility for Mitigation Implementation	Responsibility for supervision of mitigation implementation	Reporting Requirements	Approximate cost and Mitigation Cost Source
		<ul style="list-style-type: none"> <li>• DG sets; and</li> <li>• Power house and</li> <li>• Workshop area.</li> </ul>		<ul style="list-style-type: none"> <li>• Periodic audits shall be carried out for such areas and containers; also on the segregation and collection systems and the findings will be documented and appropriate action taken against irregularities;</li> <li>• A spill response plan and emergency plan shall be prepared to address accidental spillages or release of hazardous wastes; and</li> <li>• A proper manifest record shall be maintained of waste travelling/ removed from the site; and</li> <li>• Disposal of hazardous waste by engaging DOE approved waste management agencies.</li> </ul>				
2.1	Water Resources	Wastewater discharge	<ul style="list-style-type: none"> <li>• Impact on aquatic flora and fauna</li> <li>• Contamination of soil and sediment</li> </ul>	<ul style="list-style-type: none"> <li>• Monitoring of temperature at the discharge point at a frequency of every 15 days;</li> <li>• Discharge system shutdown in event that discharge temperature of effluent exceeds standard;</li> <li>• Storm water drainage and waste water of similar nature from different units will be treated in accordance to GOB Environment Conservation Rule (1997) Schedule 10 (Standards for Waste from Industrial Units or Project Waste) and the applicable World Bank Group environmental requirements and World Bank/IFC guidelines.</li> </ul>	Project Design Team to implement design phase mitigation measures.  Operations and Plant HSE Team to implement O&M Phase Mitigation Measures	HSE department and Operations.  Study by 3 <sup>rd</sup> Party agency / experts.	Records maintained and Monthly internal reports to top management and reporting to regulatory authorities/lenders as required.	<ul style="list-style-type: none"> <li>• Included in Project Capital and Plant O&amp;M Cost as mentioned above</li> </ul>
2.2	Water Resources	Surface water abstraction	<ul style="list-style-type: none"> <li>• Impact on surface water availability</li> </ul>	<ul style="list-style-type: none"> <li>• Efforts to be made to increase the cycle of concentration to reduce the volume of blow down and consequently the volume of make-up water required by the cooling tower.</li> </ul>	Operations team	Designated Team comprising of representation from HSE and Operations	Records maintained and Monthly internal reports to top management	<ul style="list-style-type: none"> <li>• Included in Project Capital and Plant O&amp;M Cost as mentioned above</li> </ul>
2.3	Water Resources	Storage and handling of Fuel, Oil and chemicals	<ul style="list-style-type: none"> <li>• Impact on soil and ground water environment</li> <li>• Storm water runoff carrying contaminants to nearby low lying areas and adjoining Channel</li> </ul>	<ul style="list-style-type: none"> <li>• For minimising use of antifouling and corrosion inhibiting chemicals appropriate depth of water intake will be maintained and use of screens will be ensured;</li> <li>• Minimum required quantities of chlorinated biocides or alternatively intermittent shot dosing of chlorine will be practised rather than continuous low level feed;</li> <li>• Waste storage areas will be equipped with secondary containment and spill control measures (similar to the hazardous material storage areas) to limit impact to ground;</li> <li>• Liquid wastes such as waste oil, etc. will be collected and stored for recycling in cemented areas; and</li> <li>• All drainage/tanks, etc. will be positioned on concrete hard standing to prevent any seepage into ground.</li> </ul>	Operations and Plant HSE Team	Designated Team comprising of representation from HSE and Operations	Records maintained and Monthly internal reports to top management	<ul style="list-style-type: none"> <li>• Included in Project Capital and Plant O&amp;M Cost as mentioned above</li> </ul>
3.1	Air Quality	Stack emissions	<ul style="list-style-type: none"> <li>• Impact on ambient air quality</li> </ul>	<ul style="list-style-type: none"> <li>• The use of continuous emission monitoring (CEM) equipment for the measurement of air emission levels in the exhaust stack of HRSG. CEM will be undertaken for NO<sub>x</sub>, SO<sub>2</sub>, CO and O<sub>2</sub>;</li> <li>• PM<sub>2.5</sub> and VOCs will be monitored periodically, to ensure that these emissions are not occurring as a result of the incomplete burning of the natural gas fuel and use of HSD as fuel.</li> <li>• The stack shall be provided with safe access to sampling points for CEM.</li> <li>• HSD shall be used only during shortage of natural gas supply.</li> </ul>	Plant HSE Team and Operations	Designated Team comprising of representation from HSE and Operations	Relevant Records maintained. Monthly internal reports to top management and reports to regulatory authorities/lenders as required.	Included in Project Capital and Plant O&M Cost
3.2	Air quality	Stack emissions	<ul style="list-style-type: none"> <li>• GHG emissions</li> </ul>	<ul style="list-style-type: none"> <li>• Ensure that all equipment and machinery is maintained in accordance with manufacturer's specifications;</li> </ul>	Plant HSE Team and Operations	Designated Team comprising of representation	Relevant Records maintained. Monthly internal reports to top	Plant O&M Cost as above

S. No.	Affected Aspect	Project Activity /affected area	Potential Impacts	Proposed Mitigation Measures	Responsibility for Mitigation Implementation	Responsibility for supervision of mitigation implementation	Reporting Requirements	Approximate cost and Mitigation Cost Source
4.1	Noise	Plant operations	<ul style="list-style-type: none"> <li>Increased noise levels</li> </ul>	<ul style="list-style-type: none"> <li>Higher efficiency steam turbine blade design; and</li> <li>Improved efficiency of auxiliary drives.</li> <li>Selection of equipment with lower sound power levels (&lt; 85 dB);</li> <li>Installation of mufflers on engine exhausts and compressor components;</li> <li>Installation of acoustic enclosures for equipment (e.g. gas turbine, compressor) casing radiating noise;</li> <li>Buildings will be designed with improved acoustic performance and sound insulation will be provided;</li> <li>Installation of acoustic barriers without gaps and with a continuous minimum surface density in order to minimize the transmission of sound through the barriers;</li> <li>Barriers will be located as close to the source ,as far as practicable, to be effective;</li> <li>Installation of vibration isolation for mechanical equipment; and</li> <li>A noise analysis of all major plant components will be carried out during commissioning of the plant to ensure compliance with the specification and guaranteed performance as well as ambient noise levels at the receptors located in the surroundings.</li> </ul>	Plant HSE Team and Operations	from HSE and Operations	management.	Included in Project Capital and Plant O&M
5.1	EMF	Magnetic fields associated with transmission and distribution systems	<ul style="list-style-type: none"> <li>Potential source of Shocks</li> </ul>	<ul style="list-style-type: none"> <li>Occupational health and safety EMF standards in EHS guidelines on thermal power and electric transmission lines shall be adhered to</li> </ul>	Plant Operations	Designated Team comprising of representation from HSE, Operations	Relevant Records maintained. Monthly internal reports to top management.	Plant O&M Cost
6.1	Climate Risk	Plant operations disruption due to flood risk, cyclones	<ul style="list-style-type: none"> <li>Loss of lives and property</li> <li>Damage to critical equipment, plants and buildings leading to safety incidents</li> </ul>	<ul style="list-style-type: none"> <li>Work closely with local authorities and BPDB on these issues a combined response is likely to be more cost-effective.</li> </ul>	Plant HSE Team and Emergency Management Team with local authorities and BPDB	Designated Team comprising of representation from HSE ,Operations, Emergency Management	Relevant Records maintained and included as part of Emergency response.	Project O&M Cost and emergency contingency fund
7.1	Aquatic ecology	Plant Operations	<ul style="list-style-type: none"> <li>Surface water abstraction</li> </ul>	<ul style="list-style-type: none"> <li>The water intake structure should have multiple size screen barriers to avoid impingement or entrainment of aquatic organism;</li> <li>Usage of barrier nets (seasonal or year-round), fish handling and return systems, fine mesh screens, and wedge-wire screens, and aquatic filter barrier systems should be explored in the water intake system.</li> </ul>	Plant HSE Team and Operations along with Specialist as required	Designated Team comprising of representation from HSE /Operations	Relevant Records maintained and internal report to senior management.	Plant O&M Cost
7.2	Aquatic Ecology	Plant operations	<ul style="list-style-type: none"> <li>Discharge of cooling water</li> </ul>	<ul style="list-style-type: none"> <li>Options for discharging water should use multiple port diffusers instead of the single point discharge should be explored;</li> <li>Options for extended length of discharge channel before reaching Dehular Khal is suggested to be explored;</li> <li>Usage of biocides should be reduced and kept to the extent required. Monitoring of the same in waste water discharge is suggested before reaching Dehular Khal;</li> <li>Fortnightly monitoring of temperature at the discharge point;</li> <li>Discharge system shutdown in the event that effluent temperature difference exceeds 3°C;</li> <li>Maintain the cooling water chemistry at approximately</li> </ul>	Plant HSE Team and Operations	Designated Team comprising of representation from HSE /Operations	Relevant Records maintained and monthly internal report to senior management and report to regulatory authorities as required.	Plant O&M Cost



S. No.	Affected Aspect	Project Activity /affected area	Potential Impacts	Proposed Mitigation Measures	Responsibility for Mitigation Implementation	Responsibility for supervision of mitigation implementation	Reporting Requirements	Approximate cost and Mitigation Cost Source
				<p>5 cycles of concentration (COC) to reduce the volume of blow down and consequently the volume of make-up water required by the cooling tower.</p> <ul style="list-style-type: none"> <li>Storm water drainage and waste water of similar nature from different units will be treated in accordance to GOB Environment Conservation Rule (1997) Schedule 10 (Standards for Waste from Industrial Units or Project Waste) and the applicable World Bank Group environmental requirements and World Bank/IFC guidelines. Treated wastewater will be discharged along with cooling water on land.</li> <li>NBBL should promote local fish breeding sites in consultation with Fishery Department with community involvement to conserve the fish resources in the Dehular Khal.</li> </ul>				
9.1	Community Health and Safety	Plant operations	<ul style="list-style-type: none"> <li>Health associated risks from air emissions and wastewater release</li> </ul>	<ul style="list-style-type: none"> <li>Same as given in 2.2, 2.2 and 2.3 and 3.1 and 3.2 (Operation Phase)</li> </ul>	Plant HSE Team and Administration	Designated Team comprising of representation from HSE /logistics team and GRC	Relevant Records maintained and monthly internal report to senior management.	Plant O&M Cost
9.2	Occupational Health and Safety	Plant operations	<ul style="list-style-type: none"> <li>Risks of accidents and fatalities to workers</li> </ul>	<ul style="list-style-type: none"> <li>On job training for the workers shall be carried out;</li> <li>Work permit system shall be followed;</li> <li>PPE shall be provided and use of PPEs shall be enforced;</li> <li>SOPs need to be developed for operation and maintenance of the Plant;</li> </ul>	Plant HSE Team and HR and Administration	Designated Team comprising of representation from HSE /HR/ Administration	Relevant Records maintained and monthly internal report to senior management.	Plant O&M Cost
<b>D</b>	<b>Cumulative Impacts</b>							
1.1	Water Resources	Surface water Abstraction and waste water discharge of all plants	<ul style="list-style-type: none"> <li>Reduction in water availability</li> <li>Contamination of water resources</li> </ul>	<ul style="list-style-type: none"> <li>For minimising use of antifouling and corrosion inhibiting chemicals appropriate depth of water intake will be maintained and use of screens shall be ensured;</li> <li>Minimum required quantities of chlorinated biocides or alternatively intermittent shot dosing of chlorine shall be practised rather than continuous low level feed;</li> <li>Waste storage areas will be equipped with secondary containment and spill control measures (similar to the hazardous material storage areas) to limit impact to ground;</li> <li>Oil water separators shall be provided to intercept any accidental discharge of oil and grease on the storm water channels;</li> <li>Liquid wastes such as waste oil, etc. shall be collected and stored for recycling in cemented areas; and</li> <li>All drainage/ tanks, etc. shall be positioned on concrete hard standing to prevent any seepage into ground.</li> </ul>	Operations Team and Plant HSE Team (Bhola-I and II projects)	Designated Team comprising of representation from HSE /Operations	<ul style="list-style-type: none"> <li>Relevant Records maintained and internal report to senior management.</li> </ul>	Plant O&M Cost
2.1	Air Quality	Operations of all plants	<ul style="list-style-type: none"> <li>Impact on Air Quality</li> </ul>	<ul style="list-style-type: none"> <li>Refer Section 3.1 and 3.2 (Operation Phase)</li> </ul>				
2.2	Air Quality	Operations of all plants	<ul style="list-style-type: none"> <li>Greenhouse gas emissions</li> </ul>	<ul style="list-style-type: none"> <li>Ensure that all equipment and machinery is maintained in accordance with manufacturer's specifications;</li> <li>Higher efficiency steam turbine blade design; and</li> <li>Improved efficiency of auxiliary drives.</li> <li>Annual GHG emissions from all the plants within the complex shall be computed based on actual fuel consumption data reported by the BPDB and NBBL for Bhola-I and II projects, respectively.</li> </ul>	Operations Team and Plant HSE Team with help from other operational plants	Designated Team comprising of representation from HSE /Operations with help from other operational plants	<ul style="list-style-type: none"> <li>Relevant Records maintained and internal report to senior management.</li> </ul>	Plant O&M Cost
3.1	Noise	Operations of all plants	<ul style="list-style-type: none"> <li>Increased noise</li> </ul>	<ul style="list-style-type: none"> <li>Installation of vibration isolation for mechanical noise</li> </ul>	Operations Team	Designated Team	Relevant Records	Plant O&M Cost

S. No.	Affected Aspect	Project Activity /affected area	Potential Impacts	Proposed Mitigation Measures	Responsibility for Mitigation Implementation	Responsibility for supervision of mitigation implementation	Reporting Requirements	Approximate cost and Mitigation Cost Source
			levels	<p>control;</p> <ul style="list-style-type: none"> <li>Once both the plants are operational, periodic ambient noise monitoring is to monitor the noise levels to ensure compliance with the specification and guaranteed performance at noise generating sources as well as ambient noise levels at the receptors located in the surroundings.</li> <li>Review of noise guarantees and supporting data of all equipment suppliers with interim noise reports from EPC contractor/s in order to demonstrate compliance with the applicable noise emission criteria at source/s. In case of exceedence from the specified noise limits, adequate corrective actions as may be required shall be implemented by the specific project.</li> </ul>	and Plant HSE Team	comprising of representation from HSE, Operations and GRC	maintained. Monthly internal reports to top management and reports to regulatory authorities/lenders as required.	

Table 7.2 Social Management and Monitoring Plan

S.N	Resource/ Receptor	Project Activity	Specific Impact	Proposed Mitigation /Safeguard Measures	Responsibility for Implementation	Responsible Parties (Supervision of monitoring)	Monitoring Indicators and Reporting Requirements	Approximate Cost and Source
1	Land and Land Use	Land requirement for construction	<ul style="list-style-type: none"> <li>Loss of agricultural land;</li> <li>Change in land-use;</li> <li>Increase in fragmentation of land;</li> <li>Linear impacts of pipeline construction</li> </ul>	<p>NBBL will implement the safeguards provided in the Resettlement Framework for the project in order to minimise the impacts from loss of land. In particular:</p> <ul style="list-style-type: none"> <li>Consideration of the implications of loss in land value due to multiple pipelines and the restrictions in use of the land within the compensation to be paid to land owners;</li> <li>Application of avoidance criteria to ensure that the pipeline route does not lead to unviable land parcels; and</li> <li>Avoid valuable land such as homestead and orchard land.</li> </ul>	Sundarban Gas Company	NBBL	As determined in the Resettlement Framework	Project Cost – this will be finalised in the RAP and LRP which is to be developed as per the Resettlement Framework
2	Local Residential Communities	Requirement of homestead land and impact on residential structures	<ul style="list-style-type: none"> <li>Physical displacement</li> </ul>	<ul style="list-style-type: none"> <li>NBBL will support the affected households in self-relocation to adjacent land parcels with formal titles;</li> <li>Compensation at replacement cost will be provided for homestead land and the residential and associated structures to enable the household to construct replacement housing;</li> <li>Additional safeguards for assisted self-relocation as provided in the Resettlement Framework will be implemented and monitored.</li> </ul>	NBBL	External Third-Party	<ul style="list-style-type: none"> <li>Inventory of households and replacement value;</li> <li>Self-relocation monitoring;</li> <li>Livelihood implications;</li> <li>Security of tenure.</li> </ul>	Project Cost
3	Economic displacement	Impact on productive land, assets and land users	<ul style="list-style-type: none"> <li>Livelihood impacts on land owners and land users</li> </ul>	<ul style="list-style-type: none"> <li>NBBL will undertake a socio-economic survey of all land owners and users for the power plant, the access road and the gas pipeline route in order to determine any economic vulnerability or loss of livelihoods due to the land loss;</li> <li>Entitlements will be provided as indicated in the Resettlement Framework;</li> <li>Access to livelihood restoration will be facilitated.</li> </ul>	NBBL	External Third-Party	<ul style="list-style-type: none"> <li>Tracking of enumeration;</li> <li>Compensation payments;</li> <li>Livelihood impacts</li> </ul>	Project Cost – to be determined after implementation of resettlement framework
4	Fishing Livelihoods	Habitat Disturbance during construction and operations phase	<ul style="list-style-type: none"> <li>Potential reduction in fishing resources and thereby a marginal reduction in come from fishing</li> </ul>	<ul style="list-style-type: none"> <li>Monitor and disallow unregulated fishing;</li> <li>Undertake monitoring of fishing livelihoods in the project’s area of influence in the construction phase;</li> <li>Consultations with the fishing households should be done before dredging and other site improvement activities are carried out at the Jetty location. Alternative anchorage areas should be identified and safe anchorage of their boats to be facilitated.</li> <li>The reduction in fish catch for these fishing households should be compensated through cash payment during the period for which jetty is used;</li> <li>Discharge water should be treated before release so that the Dehular Khal water does not get polluted and also the temperature of the discharge water should be maintained so that fish and shrimp catch in the canal does not get reduced; and</li> <li>Good management practices for compensation of fishermen in case of damage to equipment and/or any spillage.</li> </ul>	NBBL	External Third-Party	<ul style="list-style-type: none"> <li>Number of fishermen;</li> <li>Adaptation in gear;</li> <li>Fishing trips and income;</li> <li>Fish catch</li> </ul> <p>Monthly reporting</p>	Project Cost
5	Influx and In-migration	Construction and potential local procurement opportunities	<ul style="list-style-type: none"> <li>Local project labour requirements;</li> <li>Project demand for goods and services;</li> <li>Improvement in physical infrastructure;</li> <li>Perception of increased economic</li> </ul>	<ul style="list-style-type: none"> <li>Development of a Labour and Influx Management Plan and its implementation;</li> <li>Preventing stress on local infrastructure by providing labour related infrastructure such as camps, sanitation facility, drinking water facility, etc. in accordance with local regulations as well as IFC handbook for labour accommodation;</li> <li>Preparation of a detailed plan, in keeping with lender requirements, for the construction of the labour camp and the mitigation measures to be put in place</li> <li>Ensure proper administrative channel to manage labour related statutory compliance, such as payment of wages, provident fund, insurance etc. as well as labour issues arising during the construction phase activities;</li> <li>Manage illegal labour practices such as child labour, bounded labour or forced labour through internal vigilance mechanisms and surveillance; and</li> <li>Awareness shall be generated amongst migrant labourers in maintaining congenial</li> </ul>	EPC Contractors and HSE Department of NBBL	NBBL	<ul style="list-style-type: none"> <li>Number of settlements, local rents, changes in the population;</li> <li>Accidents and incidents in the local community along with grievances;</li> <li>Number of local workers</li> </ul>	<ul style="list-style-type: none"> <li>Project Developer Cost and</li> <li>EPC Contractor Cost</li> </ul>



S.N	Resource/ Receptor	Project Activity	Specific Impact	Proposed Mitigation /Safeguard Measures	Responsibility for Implementation	Responsible Parties (Supervision of monitoring)	Monitoring Indicators and Reporting Requirements	Approximate Cost and Source
6	Community Health and Safety	<ul style="list-style-type: none"> <li>Changes in environmental quality due to construction activities;</li> <li>Increased prevalence of disease arising from the influx of construction workers; and</li> <li>Heavy traffic movement.</li> </ul>	<ul style="list-style-type: none"> <li>Implications of modified environmental conditions;</li> <li>Traffic movements;</li> <li>Health risks from influx activity</li> </ul>	<ul style="list-style-type: none"> <li>relations with local labourers as well as community.</li> <li>Barriers will be provided to prevent ingress of persons into the construction site and also to protect public exposure to hazards associated with construction activities;</li> <li>Avoiding formation of stagnant water pools in and around the site;</li> <li>Implementation of a vector control programme in labour camps and surrounding areas; and</li> <li>Educating area residents and workers on risks, prevention, and available treatment for vector-borne diseases.</li> <li>Emphasizing safety aspects among drivers, particularly with regard to the speed limit of 20 km/hr that will be enforced;</li> <li>Ensuring that only licensed drivers are employed by the Project;</li> <li>Avoiding peak hours for heavy vehicles movement where possible;</li> <li>Collaboration with local communities and responsible authorities to improve signage ( e.g. pedestrian crossings, speed limits etc.), visibility and awareness of traffic and pedestrian safety;</li> <li>Educating project personnel and area residents on risks, prevention, and available treatment for vector-borne diseases.</li> <li>Screening, surveillance and treatment of workers, through the provision of medical facilities and, where required, immunization programmes.</li> </ul>	EPC Contractor	NBBL	<ul style="list-style-type: none"> <li>engaged.</li> <li>Leading and lagging health and safety indicators;</li> <li>Local commitments and grievances</li> </ul>	EPC Contractor Cost
7	Local Economic Benefits	Execution and operation across the project lifecycle	<ul style="list-style-type: none"> <li>Employment generation;</li> <li>Benefits of local enterprise;</li> <li>Rent-seeking opportunities;</li> <li>Local stimulus;</li> <li>Increase in skill levels;</li> <li>Local community development</li> </ul>	<ul style="list-style-type: none"> <li>NBBL should develop and implement a Procurement Plan prior to the start of the construction phase</li> <li>Engaging closely with local NGOs to understand the key collective requirements of the surrounding community and identify one or more of the highlighted concerns which NBBL will support to resolve.</li> <li>Some of the collective requirements could be access to (i) clean drinking water (ii) medical consultation (iii) education, etc.</li> <li>Enhance employment opportunities by maximizing utilization of the local population, as far as possible;</li> <li>Communication of a clear plan of action to improve the welfare of the neighbouring community, before commencing construction works on site.</li> </ul>	NBBL	External third-party	<ul style="list-style-type: none"> <li>Local indices of prices and market development</li> <li>Beneficiaries of CSR Programs etc.</li> </ul>	Project Cost

The environmental monitoring programme has been devised with the following objectives:

- To evaluate the effectiveness of the proposed mitigation measures and the protection of the ambient environment as per prescribed/ applicable standards for the Project;
- To identify the need for improvements in the management plans;
- To verify compliance with statutory and community obligations; and
- To allow comparison against baseline conditions and assess the changes in environmental quality in the Project AOI.

### 7.2.1

#### *Performance Indicators and Monitoring Schedule*

Physical, biological and social environmental management components of particular significance have been identified as performance indicators. A comprehensive monitoring plan for each performance indicator has been prepared for all phases of the Project and is presented in *Table 7.3*. This includes parameters to be measured, methods to be used, sampling locations, frequency of measurements, detection limits, cost and responsibilities for implementation and supervision.

### 7.2.2

#### *Reporting Mechanism for Environmental and Social Monitoring Program*

A robust reporting system will provide the Project with the necessary feedback mechanisms to ensure quality and timely implementation of the works. The reporting system will ensure regular flow of information from the Project site to the Project headquarters and, as necessary, to regulatory authorities and funding agencies. The reporting system will provide a mechanism to ensure that the measures proposed in the Project's ESMP are implemented.

Before the civil works start, the HSE Division of the Project Sponsor, in association with NBBL, will finalise the format for reporting on the status and progress of environmental monitoring. The format will be designed to meet all the compliance conditions associated with the environmental clearance from the Department of Environment and the Government of Bangladesh. The contractor will be required to submit the duly filled up reporting form on a monthly basis to the Project Developer (i.e., NBBL). A further report, detailing the results of pollution monitoring for air, noise, soil, and water will be submitted quarterly as envisaged in the monitoring plan. A health and safety incident/accident report will be prepared and submitted in the event of an incident or accident. Independent verification of the effectiveness of the mitigation measures by the EPC contractor during the construction phase can be done by NBBL HSE team with a periodic third party audit.

During the operation phase of the Project, the Operations Manager and HSE Personnel will monitor the effectiveness of the EMP implementation. The

Project Administration and Human Resources (HR) Manager will have additional responsibility of monitoring the implementation of social components of the ESMP. He/ she will also responsible for implementation of livelihood restoration and corporate social responsibility (CSR) activities to be conducted by NBBL. Both Operations Manager and HR Manager will further report to the Plant Manager, who will be overall in-charge of the Plant operations and management.

The quarterly reports of the management measures will form an integral part of the Quarterly Progress Reports that can be submitted to the lenders. Additional compliance reports to the Regional Office and Head Office of the DOE required as a part of environmental clearance process shall also be prepared and submitted based on the necessary monitoring and reporting formats.

**Table 7.3 Environmental Monitoring Programme (Construction and Operation Phase)**

Project Stage/ Affected Component	Potential Impact	Parameters to be Monitored	Location	Measurements	Frequency	Responsibility	Cost
<i>Site Preparation and Construction Phase</i>							
General	Inspection of mitigation compliance	General compliance with mitigation measures presented in the ESMP and as specified in EPC Contractor Manual	Project activity areas <sup>1</sup> and construction workers camp	Visual inspection of all active work areas	Daily	HSE Team of EPC Contractor	EPC Contractor Cost  [1 x HSSE Manager & 2 x HSSE Supervisor]
Soil	Contamination of soil and sediment	<b>Soil:</b> pH, salinity, NH <sub>4</sub> <sup>+</sup> , total P, heavy metals, oil & grease  <b>Sediment:</b> pH, heavy metals, oil & grease, sediment oxygen demand (SOD), total organic carbon (TOC), loss of ignition (LOI), total petroleum hydrocarbon (TPH)	Construction site or laydown area or spill area, run-off	Standard analytical methods	In the event of any leakage or spillage of hazardous substances, oil, or toxic chemicals	3 <sup>rd</sup> Party Environmental Consultant	BDT 200,000/ monitoring (EPC Contractor Cost)

(1) <sup>1</sup> Activity areas are defined as Project site, access road, oil handling jetty, waterway and gas pipeline RoW.

Project Stage/ Affected Component	Potential Impact	Parameters to be Monitored	Location	Measurements	Frequency	Responsibility	Cost
Water	Contamination of surface water	Turbidity, pH, DO, Total dissolved solids, oil & grease, total coliform, heavy metals	Near Temporary Jetty and near water intake and outfall structures	Standard analytical methods	Monthly	3 <sup>rd</sup> Party Environmental Consultant	BDT 660,000/ annum (EPC Contractor Cost)
	Ground water quality	Drinking water quality parameters as per Schedule 3 of ECR 1997	Groundwater wells to be used for drinking water supply during this phase	Standard analytical methods	Once every fortnight	3 <sup>rd</sup> Party Environmental Consultant	BDT 1,632,000/ annum (EPC Contractor Cost)
Ambient Air Quality	Dust generation	SPM and PM <sub>10</sub>	Identified ASRs within 200 m from the construction site (3 locations)	24-hour	Bi-monthly	3 <sup>rd</sup> Party Environmental Consultant	BDT 500,000/ annum (EPC Contractor Cost)
	Vehicle exhaust	PM <sub>2.5</sub> , NO <sub>2</sub> , SO <sub>2</sub> , CO	Identified ASRs within 100 m from the activity areas (2 locations)	24-hourly monitoring of PM <sub>2.5</sub> and SO <sub>2</sub> and 1-hourly monitoring of NO <sub>2</sub> and CO	Bi-monthly	3 <sup>rd</sup> Party Environmental Consultant	BDT 450,000/ annum (EPC Contractor Cost)
Noise	Increase in ambient noise levels	Noise levels in Leq, Leq day, Leq night and hourly Leq	Identified NSRs within 200 m from the activity area/s (5 locations)	24-hour	Bi-monthly	3 <sup>rd</sup> Party Environmental Consultant/ In-house monitoring	BDT 100,000/ annum (EPC Contractor Cost)
Occupational Health and Safety	Accidents or incidents due to construction activities, workers' health	Near-misses, incidents, occupational diseases, dangerous occurrences	Project activity areas and construction workers camp	As defined in construction phase Health & Safety Plan to be prepared by EPC contractor	As defined in H&S Plan	HSE Team of EPC Contractor	EPC Contractor Cost  [1 x HSSE Manager & 2 x HSSE Supervisor]

Project Stage/ Affected Component	Potential Impact	Parameters to be Monitored	Location	Measurements	Frequency	Responsibility	Cost
Community Health and Safety	Community disturbance and potential safety hazard due to road traffic	Accidents, incidents and complaints	Access Road connecting site	Incidents, accidents and community complaints	Based on occurrence	HSE and/or Community Liaison Officer of EPC Contractor	EPC Contractor Cost  [1 x HSSE Manager; 2 x HSSE Supervisor; 1 x Liaison Officer]
	Public concerns	Complaints from community	Neighbouring communities around the Project activity areas	As per the grievance redress mechanism	Continuous	NBBL	Grievance Management Budget of NBBL
Terrestrial Ecology	Impact on species of conservational importance	Tree cutting	RoW of gas pipeline	Identification and Enumeration by ecologist	One time prior to start of work	NBBL with help of experts	As per the compensation demanded by the Forest Department (EPC Contractor Cost)
	Impact on habitat of avifauna	Habitats and Disturbance to avifauna	Project activity areas	Visual Inspection	Once during winter season	NBBL	BDT 500,000/ (EPC Contractor Cost)
Aquatic Ecology	Impact on habitat of aquatic and riverine fauna due to spillage	Habitats and Disturbance to aquatic fauna	Near temporary jetty ,transportation route, and intake structure	Identification by experts and visual inspections	Prior to start of work and Continuous visual inspection	NBBL	BDT 300,000/ (EPC Contractor Cost)
	Impact on Reptiles due to trawlers and barges	Habitats and Disturbance to aquatic fauna	temporary jetty ,transportation route	Visual monitoring	Continuous during unloading operations at temporary jetty area and transportation route	NBBL	EPC Contractor Cost



Project Stage/ Affected Component	Potential Impact	Parameters to be Monitored	Location	Measurements	Frequency	Responsibility	Cost
<b>Operation Phase</b>							
General	Inspection of mitigation compliance	General compliance with mitigation measures presented in the ESMP and operational manual	Project activity areas	Visual inspection of all active work areas	Daily	Plant HSE Team	Included in operation and maintenance (O&M) cost
Soil	Soil and Sediment Contamination	<b>Soil:</b> pH, salinity, NH <sub>4</sub> <sup>+</sup> , total P, heavy metals, oil & grease  <b>Sediment:</b> pH, heavy metals, oil & grease, sediment oxygen demand (SOD), total organic carbon (TOC), loss of ignition (LOI), total petroleum hydrocarbon (TPH)	In waste storage area, and sediment of Dehular Khal, as applicable	Standard analytical methods	In case of Accidental spillage	3 <sup>rd</sup> Party Environmental Consultant	BDT 200,000/ monitoring (O&M Cost)
Water	Ground water quality	Drinking water quality parameters as per Schedule 3 of ECR 1997	Borewell water to be used for domestic purposes	Standard analytical methods	Monthly Quarterly	Inhouse laboratory 3 <sup>rd</sup> Party Environmental Consultant/	O&M Cost BDT 50,000/ annum
	Wastewater	Temperature, chlorine, pH, BOD <sub>5</sub> , COD, oil & grease, heavy metals, total faecal coliform	Outlet of discharge channel	Standard methods	Daily Quarterly	Inhouse laboratory 3 <sup>rd</sup> Party Environmental Consultant/	O&M Cost BDT 80,000/ annum

Project Stage/ Affected Component	Potential Impact	Parameters to be Monitored	Location	Measurements	Frequency	Responsibility	Cost
	Surface water quality	Temperature, conductivity, pH, DO, TDS	6 stations (at 0 m, 50 m and 100 m from the point of discharge of effluent on upstream and downstream)	Potable water quality analyser	Daily  Quarterly	Inhouse laboratory  3 <sup>rd</sup> Party Environmental Consultant/	O&M Cost  BDT 60,000/ annum
	Cooling water	Temperature	Intake pipeline inlet and discharge pipeline outlet	Thermistor	Continuous	Inhouse laboratory	Installation included in EPC Cost Monitoring and maintenance in O&M cost
Air Emissions	Stack emissions	NO <sub>x</sub> , CO, PM <sub>2.5</sub> and O <sub>2</sub>	Main stack and by- pass stack	CEM	Continuous	NBBL	Installation included in EPC Cost Monitoring and maintenance in O&M cost
	Emission concentrations	CEM validation for NO <sub>x</sub> , CO and PM <sub>2.5</sub>	Main stack and by- pass stack	Standard methods	Annual	3 <sup>rd</sup> Party Environmental Consultant	BDT 100,000/ annum (O&M Cost)
	Ambient air quality	NO <sub>x</sub> , CO, PM <sub>10</sub> , PM <sub>2.5</sub> , SO <sub>2</sub>	5 locations within 2 km from the Project boundary (same as baseline monitoring locations)	Standard methods	Half yearly	3 <sup>rd</sup> Party Environmental Consultant	BDT 500,000/ annum
Noise	Noise generation by Plant equipment	Sound Pressure Level	1 m from the noise generating equipment (For all the noise sources greater than 70 dB(A) noise level)	Noise monitor	Monthly  Half yearly	In-house laboratory  3 <sup>rd</sup> Party Environmental Consultant	O&M Cost  BDT 50,000/ annum

Project Stage/ Affected Component	Potential Impact	Parameters to be Monitored	Location	Measurements	Frequency	Responsibility	Cost
	Ambient noise	Ambient noise levels	At Project boundary and at nearest noise sensitive receptors in all direction from the Plant	Noise monitor with data logger (24-hour observations with hourly noise levels)	Half yearly	3 <sup>rd</sup> Party Environmental Consultant	BDT 50,000/ annum
EMF	EMF	EMF standards	Transmission line		Annual	NBBL	O&M Cost
GHG Emissions	Climate change	GHG production	Plant control room	Natural gas consumption	Annual	NBBL	No cost
Aquatic Ecology	Impact on Fishes and riverine flora and fauna	Fish count, phytoplankton's, zooplanktons numbers	Upstream , downstream of discharge point in Dehular Khal	Abundance of aquatic flora and fauna	Once post 1 year of commissioning of the plant through experts	NBBL by engaging Aquatic Ecology Expert/ Agency	BDT 300,000 (O & M Cost)
	Aquatic ecology	Visible fish kills	Water intake and outlet and downstream of Dehular Khal	Visual inspection and consultation with fishermen	Monthly	Plant HSE Team	O&M Cost
	Aquatic Ecology	Phytoplankton, zooplankton and benthos	Upstream , downstream of Dehular Khal	Abundance and species composition	Half yearly	NBBL by engaging Aquatic Ecology Expert/ Agency	BDT 200,000/ annum O&M Cost
Community Health and Safety	Community disturbance and potential safety hazard due to road/ waterway traffic	Accidents, incidents and complaints	Access Road, Dehular Khal	Incidents, accidents and community complaints	Based on occurrence	HSE and/or Community Liaison Officer of NBBL	O&M Cost
	Discharge of effluent and cooling water	Accidents, incidents and complaints	Adjoining Channel	Incidents, accidents and community complaints	Based on occurrence	HSE and/or Community Liaison Officer of NBBL	O&M Cost
	Public concerns	Complaints from community	Neighbouring communities around the Project activity areas	As per the grievance redress mechanism	Continuous	Community Liaison Officer of NBBL and Station Manager	O&M Cost

<b>Project Stage/ Affected Component</b>	<b>Potential Impact</b>	<b>Parameters to be Monitored</b>	<b>Location</b>	<b>Measurements</b>	<b>Frequency</b>	<b>Responsibility</b>	<b>Cost</b>
CSR Activities	Community Development	Activities/ Programmes and No. of beneficiaries	Vulnerable Groups around the Project activity areas	No. of beneficiaries and outcome of the activities	Periodic and need based	Admin/ HR Manager and Station Manager	CSR Budget

The ESMP (mitigation plan) will be included in the construction contract and the contractor will be responsible for implementation of the measures associated with design and construction. The Project Developer's staff, specifically the HSE Officer and Site Engineer, will monitor the implementation of these mitigation measures by the contractors at the site. These two officers will be responsible for the field level monitoring of the Project.

The roles and responsibilities of the Project Developer (NBBL) and EPC Contractor for implementation and monitoring have been outlined in *Table 7.4*. The flow diagram depicting the institutional arrangement for implementation of the ESMP is presented in *Figure 7.1*.

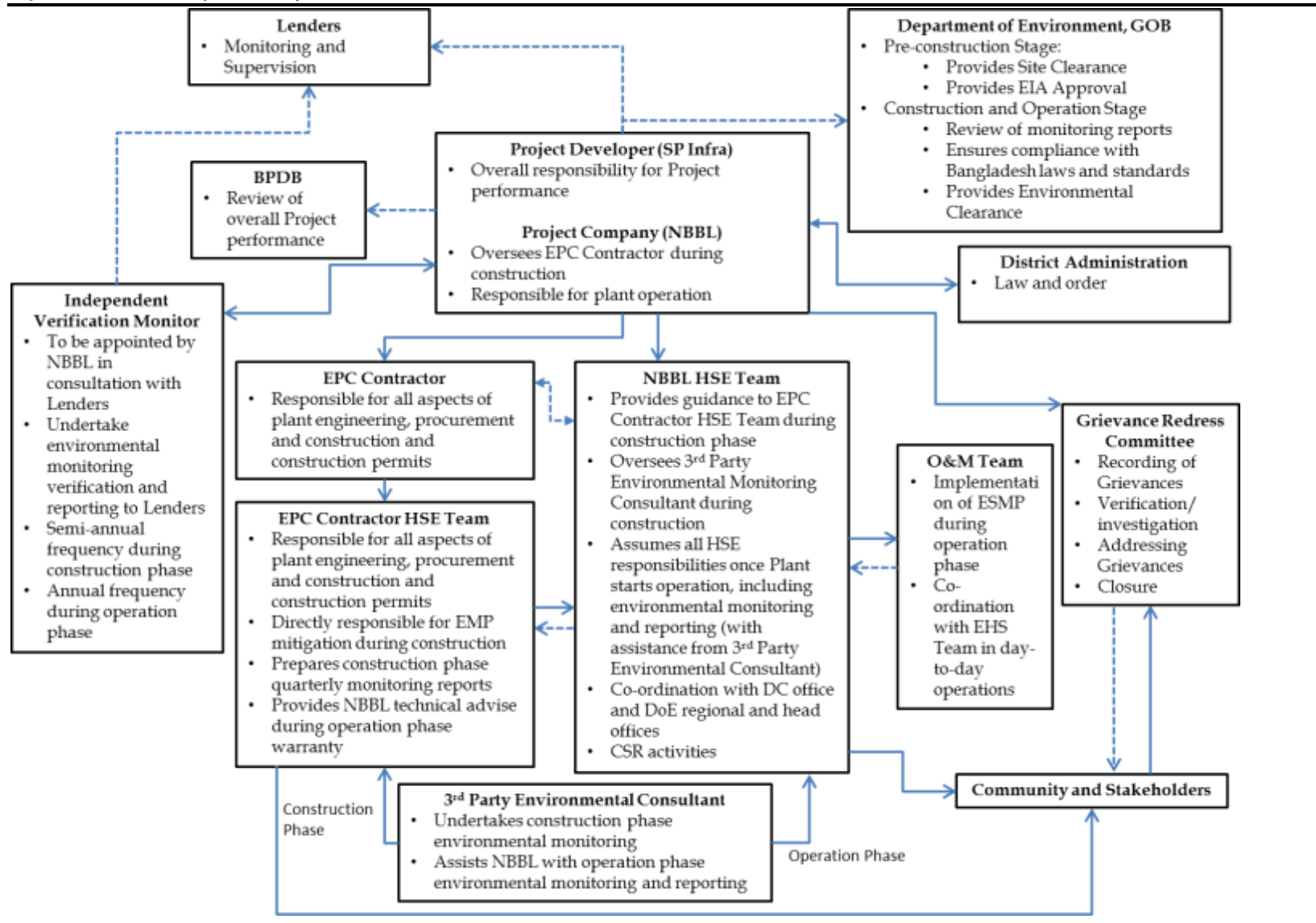
**Table 7.4** *Roles and Responsibilities of Project Developer and EPC Contractor*

<b>Project Developer (NBBL)</b>	<b>EPC Contractor</b>
Obtaining statutory clearances required during pre-construction stage of the Project	Obtaining permits required during the construction stage
Overall project co-ordination and management through EPC and supported by the third party environmental consultant/s	Joint verification with Project Developer and Third Party Environmental Consultant for review of ESMP implementation
Interaction and reporting to the respective department of GOB	Interaction with Project Developer and appointed supervision consultant, if any
Interaction and reporting to lenders	Filling of reporting formats as per the reporting schedule and submission to Project Developer
Effective implementation of ESMP and monitoring of ESMP implementation	Environmental monitoring through Third Party Environmental Laboratory
Carryout verification/ supervision exercises during the construction phase of the Project for implementation of ESMP	Preparation of various plans for effective implementation of ESMP as detailed out in the "Specification Manual" by the Project Developer
Keeping records of all permits obtained by EPC Contractor	Identification of site for labour camp, batch mix plant, laydown areas
Overall supervision of ESMP implementation	Management of labour camp and to provide drinking water, sanitation facility
Approval of plans prepared by EPC Contractor	
Addressing grievances of local community and information dissemination	
Environmental monitoring through laboratory	

While the contractor or a particular party is responsible for physical implementation of the mitigating measures, the whole implementation process requires supervision, checking, documentation and verification so that problems are identified and properly addressed before they get out of hand. In order to ensure proper execution of the EMP, implementation reviews will be conducted by the project engineer such as the weekly construction meetings, construction log book, monthly and other construction reports etc.

Records of these minutes of the weekly meeting, monthly reports and special reports on implementation of the mitigating measures will also be maintained and available for review by the Project management. It is suggested to identify documents and records that require templates and accordingly suitable templates shall be developed, which shall include but not limited to policies, procedures and work instructions, meeting minutes, monitoring results, training attendance records, emergency contract lists, action plans etc. Further, all these templates shall be communicated to all potential users. All these records will be archived at the Project office and will be maintained by the HSE officer. All documents and records shall be archived with a unique identifier so that they can be distinguished from any other material and can be easily retrieved. NBBL will document the process for creating, allocating and approving unique identifiers and will communicate this to relevant staff.

**Figure 7.1 Organization Chart for Environmental and Social Management and Reporting Responsibilities during Construction and Operation Phase of the Project**





## 7.4 TRAINING

### 7.4.1 Construction Phase

Prior to commencement of major civil works at site, a suitably qualified in-house/ external expert will be appointed by the EPC contractor in consultation with NBBL to develop and deliver a training program on implementation of the EMP, environmental monitoring and reporting in line with the applicable reference framework for the Project. The training will include the following topics:

- Environment, Health and Safety Policy of the EPC contractor;
- Environment and fundamentals of environmental pollution in relation to the Project;
- HSE management plans prepared by the EPC Contractor;
- Do's and Don'ts for the construction workers;
- Safety procedures and guidelines;
- Internal reporting and response system;
- Hazardous chemicals and waste handling;

In addition, specific training will be provided to the team involved in environmental monitoring and reporting, which will include:

- Applicable environmental guidelines and standards;
- Sampling site selection guidelines in line with environmental monitoring plan;
- Sample collection, storage, transportation and analysis procedures;
- Solid and hazardous waste management;
- Quality assurance and quality control;
- Environmental monitoring report preparation

The training will help in capacity building and implementation of the EMP during the construction phase of the Project. It will also help in ensuring internal and external monitoring and verification of the environmental performance of the Project. The reporting and verification during the construction phase will be semi-annual and the reports will be submitted to the DOE and the Lenders.

### 7.4.2 Operation Phase

Prior to the commencement of the Plant operation, a suitably qualified in-house/ external environmental expert will be engaged by NBBL to develop and deliver a training program on operation phase environmental monitoring and reporting. The topics will be mostly same as that during the construction phase. However, it will also include following modules, which are specific to the operation phase:

- Continuous emission monitoring;
- Wastewater and thermal discharge monitoring;

- Aquatic ecology monitoring;
- Hazardous chemicals and waste management;
- Occupational health and safety programs;

The training will help in capacity building and implementation of the EMP during the operation phase of the Project. It will also help in ensuring internal and external monitoring and verification of the environmental performance of the Project. The reporting and verification during the operation phase will be annual and the reports will be submitted to the DOE and the Lenders.

## 7.5 *PLANS FOR CONSTRUCTION AND OPERATION PHASE OF THE PROJECT*

### 7.5.1 *Construction Phase*

Prior to the beginning of major land works, the EPC contractor in cooperation with Project Developer will develop the following plans:

#### *Health and Safety Plan*

The EPC Contractor will prepare and implement a Health and Safety Plan prior to commencing work. This plan will include method statements for work activities, plant utilisation, construction sequence and safety arrangements. Measures will be implemented to reduce the likelihood and consequence of the following hazards:

- falling from height;
- falling into water;
- entanglement with machinery;
- tripping over permanent obstacles or temporary obstructions;
- slipping on greasy or oily walkways;
- falling objects;
- asphyxiation;
- explosion;
- contact with dangerous substances;
- electric shock;
- variable weather conditions;
- lifting excessive weights; and
- traffic operations.

#### *Construction Environmental Management Plan*

The EPC Contractor will prepare and implement a Construction Environmental Management Plan prior to commencing work to manage the construction related environmental aspects as waste management, sanitation aspects, water conservation etc.

### *Operation Phase*

During the operation phase of the Project, the Project Developer will develop the following plan/ management systems for effective operation of the Plant:

#### *HSE and Social Management System*

The Project Developer will develop and implement an HSE and Social Management System (HSE&SMS) to international guidelines for the entire Plant premises and its impact zones (project area of influence as defined under IFC PS) within two (2) years of commissioning the Plant.

#### *Waste Management Plan*

For effective segregation, handling, storage and disposal of solid and hazardous wastes generated from the Plant operations, a waste management plan will be developed by NBBL.

#### *Spill Response and Emergency Plan*

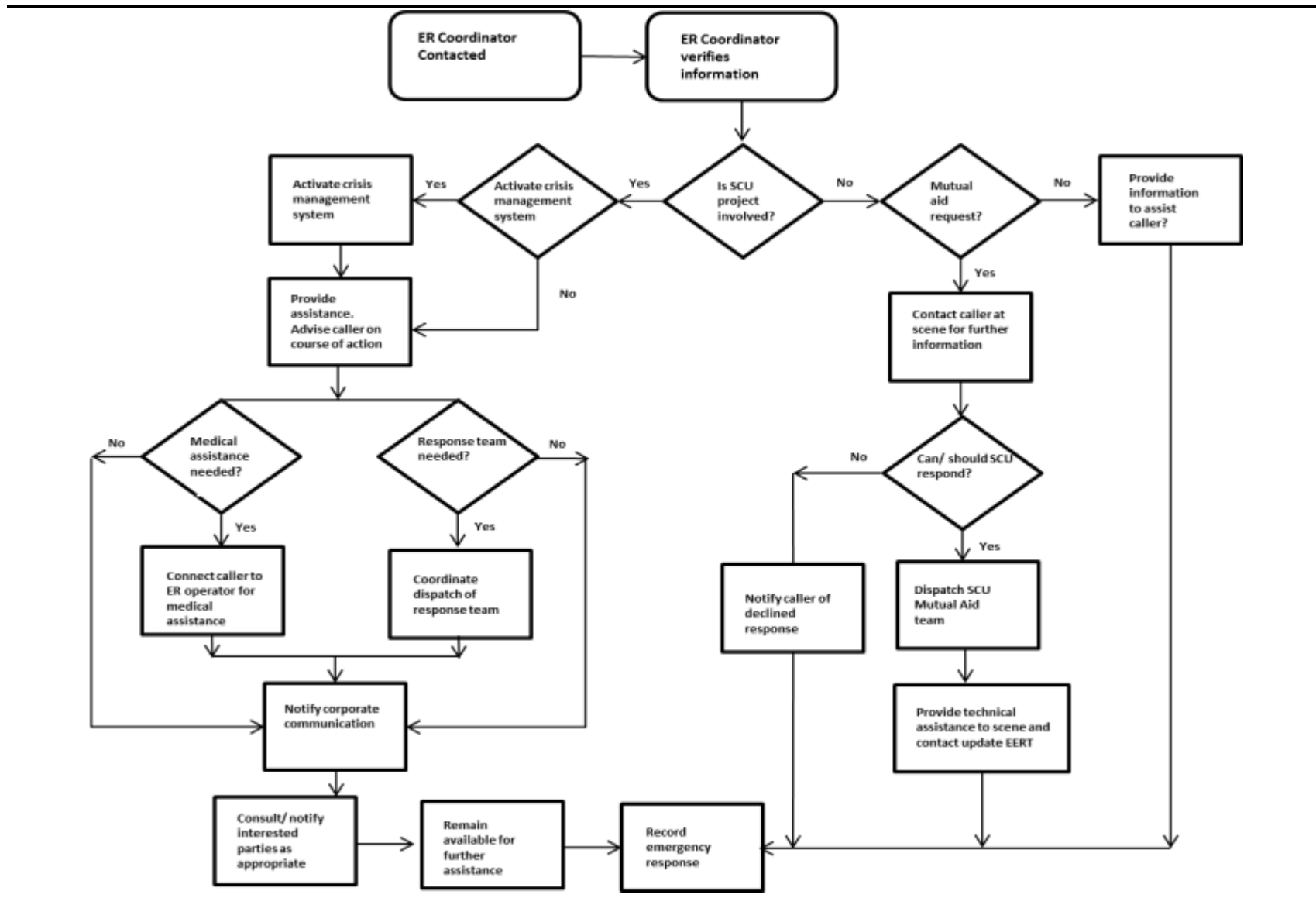
The Project Developer will prepare a spill response and emergency plan to address accidental spillages or release of hazardous wastes.

#### *Emergency Response and Disaster Management Plan*

Based on the outcome of the consequence analysis as well as detailed quantitative risk assessment of the Project after finalisation of project design, an emergency response and disaster management plan will be developed by NBBL. This will define protocols to be followed in the event of emergencies or disasters in order to limit the impact on the employees and the local community. The plan will address both on-site and off-site emergency situations due to the operation of the project. The plan will disclose potential disasters and potential risks from the plant to the local community as well as the plan of action on emergency protocol in the event of any such eventuality. This will also include awareness programs for the Plant personnel, local community and local administration.

The emergency response action tree, which can be used during the operation phase of the project, has been presented in Figure 7.2.

Figure 7.2 Emergency Response Action Tree



## 7.6 *INSPECTION, MONITORING AND AUDIT*

Inspection and monitoring of the environmental impacts of the Project activities will increase the effectiveness of ESMP. Through the process of inspection and auditing, NBBL must ensure that the conditions stipulated in various permits are complied. The entire process of inspections and audits should be documented. The inspection and audit findings are to be implemented by the site in-charge in their respective areas.

## 7.7 *REPORTING AND DOCUMENTATION*

NBBL will develop and implement a programme of reporting through all stages of the project cycle. Delegated personnel shall require to fully complying with the reporting programme in terms of both timely submissions of reports as per acceptable level of detail. Reporting will be done in form of environmental check list, incident record register, environmental and social performance reports (weekly, monthly, quarterly, half yearly, yearly etc.).

### 7.7.1 *External Reporting and Communication*

The EHS head is responsible for ensuring that communication with regulatory agencies and stakeholders are maintained as per the requirement. All complaints and enquiries are to be appropriately dealt with and records should be maintained in a Complaint/Enquiry Register by the delegated staff of EHS.

### 7.7.2 *Internal Reporting and Communication*

Inspection and audits finding along with their improvement program are to be regularly reported to the senior management for their consideration. The same are also to be communicated with the staff working on the project. To maintain an open communication between the staff and management on EHS and social issues the followings are being used:

- Team Briefings;
- On-site work group meetings;
- Work Specific Instructions; and
- Meeting with stakeholders.

### 7.7.3 *Documentation*

Documentation is an important step in implementing ESMP. NBBL will establish a documentation and record keeping system to ensure recording and updating of documents per the requirements specified in ESMP. The documents should be kept as hardcopies as well as in electronic format. Responsibilities have to be assigned to relevant personnel for ensuring that the ESMP documentation system is maintained and that document control is ensured through access by and distribution to, identified personnel in form of the following:

- Master Environment Management System document;
- Operation control procedures;
- Work instructions;
- Incident reports;
- Emergency preparedness and response procedures;
- Training records;
- Monitoring reports;
- Auditing reports; and
- Complaints register and issues attended/closed.

## 7.8 *STAKEHOLDER ENGAGEMENT*

*Annex XI* provides an overview of the project-specific Stakeholder Engagement Plan which will be implemented by NBBL.

In order to manage these risks, an internal mechanism is required to be in place where the aggrieved party/s can lodge their complaints and get it amicably settled prior to approaching the formal mode of solution available to them i.e. access to legal system through courts. In order to provide a formal forum to the aggrieved parties to deal with issues arising out of project, it is proposed that a joint grievance redress mechanism be instituted for both environmental and social related issues.

The proposed Grievance Redress Mechanism (GRM) will be developed for the Project in order to settle as many disputes as possible through consultations, negotiation and mutual settlement. Such a mechanism is important as it is expected that most cases, if not all, would be resolved amicably; and the process, as a whole, will promote dispute settlement through mediation to reduce litigation. However, the options of legal recourse will not be restricted in any way by the project proponent.

This will be implemented concurrently with the Gender Action Plan and the Resettlement Framework.

## 7.9 *ESMP REVIEW AND AMENDMENTS*

The ESMP acts as an environment and social management tool which needs to be reviewed periodically to address changes in the organisation, process or regulatory requirements. Following a review, the EHS head of NBBL will be responsible for making the amendments in the ESMP. The amended ESMP will be communicated to all the staff.

## 7.10 *BUDGET*

The EPC Contractor and NBBL will allocate separate budget for environmental and social management plan implementation, training,

environmental monitoring, analysis and reporting, verification monitoring and capacity building. It should be noted that costs for many in-built mitigation measures, such as, acoustic enclosures for noise control, water and wastewater treatment, CEM, etc., are already included in the EPC contract cost estimate and/or operating cost estimates. In addition, separate budget will be allocated for CSR activities, which will be conducted by the Project Developer for community development. The budget estimate for the 3<sup>rd</sup> party monitoring and/or verification has been included in Table 7.3.



Participation is a process, through which stakeholders influence and share control over development initiatives and the decisions and the resources which affect them. The effectiveness of the environment and social management plan is directly related to the degree of continuing involvement of stakeholders in the Project development process. Participation of stakeholders in the Project is also a primary requirement in developing an appropriate ESMP that addresses Project's requirement and is suited to the needs of the stakeholders. Stakeholder's involvement also vastly increases the probability of successful implementation of the management plan. In order to make the consultation and disclosure process effective and fruitful, comprehensive planning is required to assure that the impacted community, local government, NGOs, host population and Project staff interacts regularly and purposefully, throughout all stages of the Project and contribute toward a common goal.

### 8.1 *APPROACH AND METHODOLOGY FOR CONSULTATION*

The approach undertaken for information sharing and consultation involved the following key processes.

- Mapping and identification of key stakeholders such as primary (directly influenced by the Project) and secondary (indirectly influenced by the Project) stakeholders;
- Undertaking expert consultations, interviews and focussed group discussions (FGD) with the respective stakeholders;
- Assessing the influence and impact of the Project on these stakeholder groups;
- Summarizing key findings and observations from the consultations; and
- Preparing a future stakeholder engagement strategy for a more detailed assessments at a more detailed level taking into account the various Project lifecycle phases and their implications on the stakeholder .

### 8.2 *STAKEHOLDER ASSESSMENT*

A stakeholder is defined as “a person, group, or organization that has direct or indirect stake in a Project/organization because it can affect or be affected by the Project or its Proponent's actions, objectives, and policies”. Stakeholders vary in terms of degree of interest, influence and control they have over the Project or the proponent. In the present study, all the stakeholders have been primarily categorized into two categories that have been identified as:

- **Primary Stakeholders:** include people, groups, institutions that either have a direct influence on the Project or are directly impacted (positively or adversely) by the Project and its activities; and
- **Secondary stakeholders:** are those that have a bearing on the Project and its activities by the virtue of their being closely linked or associated with the primary stakeholders and due to the influence they have on the primary stakeholder groups.

### 8.3

#### STAKEHOLDER MAPPING

Stakeholder mapping is a process of examining the relative influence that different individuals and groups have over a project as well as the influence of the project over them. The purpose of a stakeholder mapping is to:

- Identify each stakeholder group;
- Study their profile and the nature of the stakes;
- Understand each group's specific issues, concerns as well as expectations from the project that each group retains.
- Gauge their influence on the Project;

Apart from categorization, stakeholders have also been classified in accordance with the level of influence they have over the Project as well as their priority to the Project proponent in terms of importance.

The influence and priority have both been primarily rates as:

- **High Influence/Priority:** Which implies a high degree of influence of the stakeholder on the Project in terms of participation and decision making or a high priority for the Project proponent to engage that stakeholder
- **Medium Influence/Priority:** Which implies a moderate level of influence and participation of the stakeholder in the Project as well as a priority level for the Project proponent to engage the stakeholder who are neither highly critical nor are insignificant in terms of influence.
- **Low Influence/Priority:** Which implies a low degree of influence of the stakeholder on the Project in terms of participation and decision making or a low priority for the Project proponent to engage that stakeholder

Based on the above attributes, **Table 8.1** delineates the stakeholders identified for the Project and their analysis.

The following table provides brief profiles of the various stakeholders in the project as discussed in the previous sub section along with their key concerns in association of the project and their degree of influence.

**Table 8.1 Stakeholder Profile and Mapping**

Stakeholder Group	Profile/Status	Concerns surrounding the project	Expectations from the project	Influence on Project	Rating of Stakeholder Priority
Physically Displaced and Economically Displaced	<p>There are four ( 4) households who will be physically displaced due to the procurement of land having residential structures of these households. Three households are located on the pipeline route and one household is located on the access road route.</p> <p>Economically Displaced are those landowners who will lose complete or portions of their land holding as part of the land acquisition for the project. There will be 63 households who have been impacted for land procurement for the plant. In addition, 200-250 land owners will be impacted for right of way of the gas pipeline.</p>	<p>The primary concerns of these stakeholders pertain to the displacement process and resettlement options; adequacy of the mitigation measures to be undertaken by GMR in mitigating the project impacts on their livelihoods. Apprehensions revolve around the impacts the project may have on the PAFs in the absence of sound livelihood restoration programme. These concerns are the strongest amongst land owners who will lose access to their previous land holdings due to the land acquisition for the project.</p> <p>Concerns of these stakeholders pertain to adequate compensation for land purchase and compensation regarding crops and trees. These stakeholders expressed their concern regarding the adequacy of the mitigation measures to be undertaken by NBBL.</p>	<p>The expectations of these stakeholders are as follows:</p> <ul style="list-style-type: none"> <li>• Adequate compensation for mitigation of the project impacts</li> <li>• Formulation and implementation of livelihood restoration programmes and other community development programmes so as to mitigate the impacts of the project (landlessness, access loss)</li> <li>• Timely and complete sharing of information pertaining to the project by NBBL</li> </ul>	<p>This group would be the most impacted in terms of economic/livelihood impacts. Absence of a livelihood restoration programme and resettlement planning may result in the creation of negative opinion against the project.</p>	High
Land users and Sharecroppers	<p>The project area has been observed to have land users</p>	<p>The primary concerns of these stakeholders surround</p>	<p>The expectations from the project pertain to the following:</p>	<p>Absence of adequate compensation and a</p>	High

Stakeholder Group	Profile/Status	Concerns surrounding the project	Expectations from the project	Influence on Project	Rating of Stakeholder Priority
	(bargadars) and tenants. There are approximately 25 land users which will be impacted due to land procurement for power plant. .	the apprehension that due to the fact that the land in question is not owned by them, compensation for the crops would not be provided and would thereby impact their livelihood	<ul style="list-style-type: none"> <li>• Awarding of adequate compensation for the land lost.</li> <li>• Formulation and implementation of comprehensive livelihood restoration measures and community development programmes</li> <li>• Timely and complete sharing of information pertaining to the project by NBBL</li> </ul>	livelihood restoration programme may result in the creation of negative opinion against the project.	
Vulnerable Communities	Vulnerable groups comprise of the traditionally backward and marginalized communities, women headed households, differentially abled people, old, infirm, Below Poverty Line (BPL) families	The primary concerns of these stakeholders pertain to the formulation of community development and mitigation measures in such a manner while keeping in mind their specific needs and vulnerabilities attached to economic and social capital. .	<p>Expectations from the project are:</p> <ul style="list-style-type: none"> <li>• Formulation of mitigation measures (in terms Community Development Activities)which would cater to the specific requirements of each of these groups</li> <li>• Timely and complete disclosure of information pertaining to the project by NBBL</li> </ul>	Despite the fact that these groups may not be able to exert much influence on the project & project activities, these are an important and most significant section of PAPs and their needs have to be understood in order to design specific measures to improve their vulnerability status.	High
Fishing community	There are a few households identified in the project area who are engaged in fishing either only during peak season or throughout the year. The main fishing settlements in terms of fishermen population are closer to Tetuliya River and settlements of Dakshin Choto Monika, Char Ghazipur near	The primary concerns of these stakeholders pertain to the impacts of the project on their livelihood in terms of river flow, fish count and catch, size of fishes in operational phase and adequacy of the mitigation measures to be undertaken by NBBL.	<p>The expectations of these stakeholders are as follows:</p> <ul style="list-style-type: none"> <li>• To be involved in the livelihood restoration measures</li> <li>• To be adequately informed and involved in the project implementation mitigation process at the project level</li> </ul>	There are households engaged in fishing activities and their ability to exert influence on project related activities and opinion making should be considered.	Medium

Stakeholder Group	Profile/Status	Concerns surrounding the project	Expectations from the project	Influence on Project	Rating of Stakeholder Priority
	Dehular Khal.				
Union Parishads (UP)	Union Parishads are lowest levels of local governance and consists of nine wards. The two (2) Unions Parishads, where private is to be procured from-Kutba and Kachia. Remaining five (5) UPs are equally important as UPs are representatives of local community and in order for the smooth and proper functioning of the project, the support of the UPs is imperative.	The primary concerns of these stakeholders pertain to the impacts of the project on the villages, adequacy of the mitigation measures to be undertaken by NBBL.	The expectations of these stakeholders are as follows: <ul style="list-style-type: none"> <li>To be adequately informed and involved in the project implementation mitigation process at the project level</li> <li>To be involved in the formulation and implementation of the compensation and the livelihood restoration programmes and community development programmes</li> <li>Formulation and implementation of livelihood restoration programmes and other community development programmes</li> <li>Adequate compensation for mitigation of the project impacts</li> <li>Project benefits to villages on the basis of the level of impact.</li> </ul>	Most of the communication and development activities are routed through the UPs. Furthermore, the UPs are extremely important as opinion makers within the community and are thus critical in securing the support of the local community	High
Project Investors	Project investors may have requirements which must be fulfilled for various projects they invest in. These requirements are enlisted as guidelines such as IFC Performance Standards (IFC PS) on Social and Environmental Sustainability	The primary concerns of these stakeholders are the proper compliance of the project to their standards as well as the government regulations. Another concern may be the adequate mitigation of the negative impacts of the project	The expectations of these stakeholders are as follows: <ul style="list-style-type: none"> <li>Compliance with the applicable standards</li> <li>Adequate compensation for mitigation of the project impacts</li> <li>Timely and complete disclosure of information</li> </ul>	As the investors in the project, the influence of investor is high.	High

Stakeholder Group	Profile/Status	Concerns surrounding the project	Expectations from the project	Influence on Project	Rating of Stakeholder Priority
	and ADB SPS (2009)		<p>pertaining to the project by NBBL</p> <ul style="list-style-type: none"> <li>Provision of regular updates in regards to the progress of the project</li> </ul>		
Regulatory Authorities	The regulatory authorities comprise of the DoE and district and upazila level bodies generally involved in the determination of compensation, providing environmental and land clearances for various project components. These include the departments of Upazilla Chairman, DM, forest, land revenue, agriculture, health, energy, irrigation, public works, sanitation amongst others	The primary concern of these stakeholders is that the project complies with all the regulatory requirements applicable on the project.	<p>The expectations of these stakeholders from the project are:</p> <ul style="list-style-type: none"> <li>Compliance with the regulatory requirements applicable</li> <li>Timely and complete disclosure of information pertaining to the project by NBBL</li> <li>Provision of regular updates in regards to the progress of the project</li> </ul>	Adherence with the various rules and regulations of such authorities and the various clearances required from the same are instrumental in the smooth functioning of the project	High
Villages within the project impact area	This stakeholder group comprises of the members of the study area, who even though will not lose any land to the project area are to be impacted by the project and other ancillary activities due to the project being located within a short distance. This is mostly central for villages located in the study area (within 5 km radius) where the project will result in environmental and social impacts.	The primary concerns of these stakeholders pertain to the project benefits which would percolate to them	<p>Expectations from the project are:</p> <ul style="list-style-type: none"> <li>Adequate community development measures and other project benefits</li> </ul>	The support of these villages will enable the smooth functioning of the project	Medium-Low:

Stakeholder Group	Profile/Status	Concerns surrounding the project	Expectations from the project	Influence on Project	Rating of Stakeholder Priority
Political Parties	Political parties showcase a keen interest in the working of the various projects in the region. They play a key role in sensitising people and developing public opinion. The political parties also play a key role in the negotiation process.	The primary concerns of these stakeholders pertain to the provisioning of adequate compensation and community development measures to the impacted communities	The expectations of these stakeholders from the project are: <ul style="list-style-type: none"> <li>• Compliance with the regulatory requirements applicable</li> <li>• Timely and complete disclosure of information pertaining to the project by NBBL</li> <li>• Provision of regular updates in regards to the progress of the project</li> <li>• Adequate compensation for/ mitigation of the project impacts in terms of livelihood restoration and other Community Development Activities</li> </ul>	Political parties in any region are capable of influencing (to a varying degree) the public opinion regarding a project or a component of the project.	Medium-High:
Local NGOs	The local NGOs have a very strong presence and primarily deal with issues of livestock, savings and micro credit, improvement of education and rural development.	The primary concerns of these stakeholders pertain to the provisioning of adequate mitigate measures and community development programmes by NBBL	The expectations of these stakeholders from the project are: <ul style="list-style-type: none"> <li>• Adequate community development programmes in the area.</li> <li>• Timely and complete disclosure of information pertaining to the project by NBBL</li> <li>• Provision of regular updates in regards to the progress of the project</li> <li>• Involvement of the local NGOs in the identification of these mitigate measures</li> <li>• Engagement of NBBL in</li> </ul>	NGOs can play an extremely important role in forming public opinions regarding the project; Local NGOs can be partners in implementation of LRP and other community development measures.	Medium



Stakeholder Group	Profile/Status	Concerns surrounding the project	Expectations from the project	Influence on Project	Rating of Stakeholder Priority
			the NGO activities so as to contribute towards the development of the region		
Media	The regional press (both print and audio-visual) has in the past showcased a keen interest in the projects coming up in the region and power sector. They are known to play important role in generating awareness in previous projects.	The primary concerns of these stakeholders pertain to the provisioning of adequate mitigate measures by NBBL as well as compliance of the project to the statutory requirements applicable.	The expectations of these stakeholders from the project are: <ul style="list-style-type: none"> <li>• Timely and complete sharing of information pertaining to the project by NBBL</li> <li>• Provision of regular updates in regards to the progress of the project</li> </ul>	These stakeholders play an important role in generating awareness and forming public opinion through the dispersion of information	Medium
Other Industries/ projects	There is one more power plant (BPDB) in the study area and one 35 MW power plant near Bhola. There may also be future projects in the pipeline.	The primary concerns of these stakeholders pertain to the issues which may arise due to differential compensations across projects. This is a concern as in cases of NBBL providing high compensation packages or better community development programmes; it is likely to create benchmarks for the other companies. These benchmarks would then have to be matched by the others so as to ensure the smooth functioning of their projects.	The expectations of these stakeholders involve collaboration across the projects in terms of investments made in the community development activities as well as the compensation packages provided	Collaboration with the other power companies in the region will allow for the optimization of the investments made by the project proponents towards the community development activities	Low
Bangladesh Power Development Board	<ul style="list-style-type: none"> <li>• The BPDB is responsible for major portion of generation and distribution of electricity mainly in urban areas except Dhaka and West Zone of the country.</li> </ul>		Timely commencement of operation of the project as well as compliance of the project to the statutory requirements applicable.	<ul style="list-style-type: none"> <li>• The land lease agreement (LLA) and power purchase agreement will be executed between NBBL and BPDB.</li> <li>• In the event of gas</li> </ul>	High

Stakeholder Group	Profile/Status	Concerns surrounding the project	Expectations from the project	Influence on Project	Rating of Stakeholder Priority
	<ul style="list-style-type: none"> <li>The Board is under the Power Division of the Ministry of power, Energy and Mineral Resources, Government of Bangladesh.</li> </ul>			supply failure to the project, BPDB need to instruct NBBL to switch to HSD.	
External Influences	These stakeholders comprise of residents from neighbouring villages or districts (such as community spoke persons, local leaders) who appear to be influential in the opinion formation amongst the impacted villages. These stakeholders would not only comprise of people who are working for the benefit of the community but also those who maybe opportunistic and on the lookout to achieve personal gains.	The primary concerns of these stakeholders pertain to the opinion that the present mitigation measures being undertaken appear to be insufficient.	The expectations of these stakeholders involve Adequate compensation for mitigation of the project and overall benefit and community development of the area	These stakeholders may have an important role to play in terms of in forming public opinions regarding the project.	Low
Department of Environment (DoE) Ministry of Environment and Forest, Bangladesh	<ul style="list-style-type: none"> <li>The Department of Environment is the primary government regulatory authority for Environmental protection in Bangladesh.</li> <li>The closest office is located in Bogra District</li> </ul>	The primary concern of these stakeholders is that the project complies with all the regulatory requirements applicable on the project.	<p>The expectations of these stakeholders from the project are:</p> <ul style="list-style-type: none"> <li>Compliance with the regulatory requirements applicable</li> <li>Timely and complete disclosure of information pertaining to the project by NBBL</li> <li>Provision of regular updates in regards to the progress of the project</li> </ul>	<ul style="list-style-type: none"> <li>Government Regulatory agency to provide Environmental Clearance (EC) to the Project based on evaluation and approval of Environmental Impact Assessment (EIA) study</li> <li>Responsible for monitoring the Project's Environmental compliance</li> </ul>	High

Stakeholder Group	Profile/Status	Concerns surrounding the project	Expectations from the project	Influence on Project	Rating of Stakeholder Priority
				throughout the Project lifecycle	
District Commissioners Office (DCO), Bhola	<ul style="list-style-type: none"> <li>The District commissioners office is the most senior administrative authority within the district</li> </ul>	The primary concern of these stakeholders is that the project complies with all the regulatory requirements applicable on the project.	<p>The expectations of these stakeholders from the project are:</p> <ul style="list-style-type: none"> <li>Compliance with the regulatory requirements applicable</li> <li>Timely and complete disclosure of information pertaining to the project by NBBL</li> <li>Provision of regular updates in regards to the progress of the project</li> </ul>	<ul style="list-style-type: none"> <li>The participation of the district commissioners office is restricted to permitting and clearances</li> <li>Is the primary agency for overseeing the Project's compliances to local administrative rules and regulations</li> </ul>	Low
Local Government Engineering Department (LGED), Bhola	<ul style="list-style-type: none"> <li>Local Government Engineering Department (LGED) is one of the largest public sector organizations in Bangladesh entrusted with planning and implementation of local level infrastructure development programs.</li> </ul>	The primary concern of these stakeholders is that the project complies with all the regulatory requirements applicable on the project.	<p>The expectations of these stakeholders from the project are:</p> <ul style="list-style-type: none"> <li>Compliance with the regulatory requirements applicable</li> <li>Timely and complete disclosure of information pertaining to the project by NBBL</li> <li>Provision of regular updates in regards to the progress of the project</li> </ul>	<ul style="list-style-type: none"> <li>Is responsible for maintenance of the approach road to the Project site over the lifecycle of the Project</li> </ul>	Low
Directorate of Labour, Ministry of Labour and Employment	<ul style="list-style-type: none"> <li>Primary nodal agency for creating employment opportunities, implementation for labour laws, fix minimum wages of labour, and ensuring addressal of labour related grievances through labour</li> </ul>	The primary concern of these stakeholders is that the project complies with all the regulatory requirements applicable on the project.	<p>The expectations of these stakeholders from the project are:</p> <ul style="list-style-type: none"> <li>Compliance with the regulatory requirements applicable</li> <li>Timely and complete disclosure of information</li> </ul>	<ul style="list-style-type: none"> <li>All labour related permits and licences have to be procured by both NBBL as the principal employer as well as the contractors and sub-contractors working</li> </ul>	Medium

Stakeholder Group	Profile/Status	Concerns surrounding the project	Expectations from the project	Influence on Project	Rating of Stakeholder Priority
	courts		<p>pertaining to the project by NBBL</p> <ul style="list-style-type: none"> <li>Provision of regular updates in regards to the progress of the project</li> </ul>	<p>in the Project</p> <ul style="list-style-type: none"> <li>Responsible for undertaking periodic audits and compliance check at the site in order to ensure proper implementation of the local labour regulations</li> </ul>	
Dept. of Social Welfare (DSW)	<ul style="list-style-type: none"> <li>Local governmental agency responsible for implementation of governmental social welfare schemes and activities in Bhola District.</li> </ul>	The primary concern of these stakeholders is that the project complies with all the regulatory requirements applicable on the project.	<p>The expectations of these stakeholders from the project are:</p> <ul style="list-style-type: none"> <li>Compliance with the regulatory requirements applicable</li> <li>Timely and complete disclosure of information pertaining to the project by NBBL</li> <li>Provision of regular updates in regards to the progress of the project</li> <li>Partnership in working on community development projects</li> </ul>	<ul style="list-style-type: none"> <li>No major influence on Project related activities</li> <li>However participation level and influence may increase in case community welfare activities proposed by the Project proponent are implemented in coordination with this agency</li> </ul>	Low
Dept. of Public Health and Engineering	<ul style="list-style-type: none"> <li>Primary department responsible for managing the overall healthcare facilities in the district</li> <li>Local community healthcare centres and hospitals functioning under this department are responsible for providing medication and healthcare</li> </ul>	The primary concern of these stakeholders is that the project complies with all the regulatory requirements applicable on the project.	<p>The expectations of these stakeholders from the project are:</p> <ul style="list-style-type: none"> <li>Compliance with the regulatory requirements applicable</li> <li>Timely and complete disclosure of information pertaining to the project by NBBL</li> </ul>	<ul style="list-style-type: none"> <li>No major influence on Project related activities</li> <li>Key agency responsible for managing healthcare facilities around the Project area</li> <li>Controlling out-</li> </ul>	Low

Stakeholder Group	Profile/Status	Concerns surrounding the project	Expectations from the project	Influence on Project	Rating of Stakeholder Priority
	facilities to the community		<ul style="list-style-type: none"> <li>Provision of regular updates in regards to the progress of the project</li> <li>Partnership in working on community development projects</li> </ul>	break of any major disease and monitoring the disease pattern	
Other Regulatory & Permitting Authorities	<ul style="list-style-type: none"> <li>Bangladesh Railways for obtaining railways related clearances for transportation of HSD</li> <li>Bangladesh Water Development Board (BWDB) for transportation of material and resources through the Jamuna River</li> </ul>	The primary concern of these stakeholders is that the project complies with all the regulatory requirements applicable on the project.	<p>The expectations of these stakeholders from the project are:</p> <ul style="list-style-type: none"> <li>Compliance with the regulatory requirements applicable</li> <li>Timely and complete disclosure of information pertaining to the project by NBBL</li> <li>Provision of regular updates in regards to the progress of the project</li> <li></li> </ul>	<ul style="list-style-type: none"> <li>Agencies required for obtaining permits and licenses for establishment and operation of the Project</li> <li>Primary involvement during pre-construction and operation phases</li> </ul>	Medium
Contractors (local and foreign)	<ul style="list-style-type: none"> <li>Contractors include OEM (Original Equipment Manufacturers), part suppliers, mechanical installers and maintenance service providers who would be engaged during the Project lifecycle</li> </ul>	The primary concern of these stakeholders is that the project complies with all the regulatory and contract agreement requirements applicable on the project.	<ul style="list-style-type: none"> <li>Timely and complete disclosure of information pertaining to the project by NBBL</li> <li>Provision of regular updates in regards to the progress of the project</li> </ul>	<ul style="list-style-type: none"> <li>Construction phase will require almost 1500 people (for both civil and mechanical work), during peak construction stage, including both local and migrant workers over a span of almost 2 and a half years</li> <li>Engagement levels would be mostly during construction, and</li> </ul>	Medium

Stakeholder Group	Profile/Status	Concerns surrounding the project	Expectations from the project	Influence on Project	Rating of Stakeholder Priority
				decommissioning phases	
Migrant Workers and Labourers	<ul style="list-style-type: none"> <li>Labourers and workers arriving from outside of Bhola District for participating in construction activities</li> </ul>	The primary concern of these stakeholders is that the project complies with all the regulatory and contract agreement requirements applicable on the project including safeguards and provisions for accommodation, wages, occupational health and safety.	<ul style="list-style-type: none"> <li>Timely and complete disclosure of information pertaining to the project by NBBL</li> <li>Provision of regular updates in regards to the progress of the project</li> </ul>	<ul style="list-style-type: none"> <li>Responsible for undertaking mostly skill based work during construction phase</li> <li>Engagement level during both civil and mechanical phases of work</li> </ul>	Medium
Local Workers and Labourers	<ul style="list-style-type: none"> <li>Labourers and workers recruited from the Area of Influence mostly during the construction phase of the Project</li> </ul>	The primary concern of these stakeholders is that the project complies with all the regulatory and contract agreement requirements applicable on the project including preference for casual work, safeguards and provisions for accommodation, wages, occupational health and safety.	<ul style="list-style-type: none"> <li>Timely and complete disclosure of information pertaining to the project by NBBL</li> <li>Provision of regular updates in regards to the progress of the project</li> <li>Provision of local employment as preference</li> </ul>	<ul style="list-style-type: none"> <li>Responsible for undertaking mostly un-skill based work during construction phase and housekeeping related work during operation phase of the Project</li> <li>Engagement level primarily in civil construction part of the work</li> </ul>	Medium

## 8.4

### *INFORMATION DISCLOSURE AND CONSULTATION*

This section discusses the key engagement mechanisms adopted by the project proponents and their partners for project disclosure and stakeholder engagement thus far:

#### 8.4.1

##### *Land Ownership Identification*

NBBL has undertaken verification of and consultation with land owners regarding ownership, inheritance and mutation of records between May 2016 to January 2017. This is being undertaken along with the Burhanuddin Upazila Chariman office and Land and Revenue department. Verification of mauza maps, drawings and on-field verification and ground-truthing of owner information was undertaken to correctly identify land ownership.

The land parcels have been identified and currently, 63 land owners have been identified who will be impacted due to land procurement for the power plant. 21 land sale agreements have also been executed with these land owners in January 2017 based on their signed consent to the rates per decimal that was negotiated at a Union level.

As of March 2017, the details of parcel and land ownership identification for the gas pipeline has been complete and it is understood that Land ownership verification of the route for gas pipeline is currently underway and it is expected that approximately 132 land owners will be impacted by right of way acquisition. This acquisition will be carried out by Sunderban Gas Company Limited.

The consultant undertook a review of land ownership information made available by NBBL and consulted the impacted villagers to trace and identify land owners for discussions and household surveys.

#### 8.4.2

##### *Consultations during ESIA Preparation*

A combination of mixed methods of information disclosure and consultation processes was adopted at this stage of ESIA preparation. The method selected for consultation was designed keeping in mind the profile of the stakeholders, type of information desired and level of engagement required. In each consultation session the consultant introduced themselves, introduced the Project and the purpose of engagement with the respective stakeholder. The primary methods followed in the consultation process are:

- Individual level consultation/discussion;
- Focus group discussion; and
- Community meetings.

A number of consultation exercises were conducted during preparation of this ESIA. The stakeholders consulted include the community in the direct vicinity of the Project area, local elected representative such as the Upazila Chaimramn of Burhanuddin and the Union Chairmen of Kutba, Sachra and Kachia Unions, and other external stakeholders such as relevant government



departments and NGOs. The details of key feedback from the consultations held and suggestions provided have been provided in *Annexure U*.

## 8.5

### KEY FEEDBACK

The main findings and observations from the consultation have been summarised here:

- ***Residual issues from the existing Power Plant:*** the consultation with the local community in *Dakshin Choto Monika* and *Dakshin Kutba* revealed that there was some level of community health and safety issues within the local community with respect to the noise levels of existing BPDB power plant adjacent to the Project site. Also there were reports of dissatisfaction with respect to compensation, fragmentation of land due to the transmission corridor right of way and a lack of CSR initiatives amongst others. The current Project development has to be clearly presented to the community as a separate development in order to avoid any confusion within the community, who may associate the development with the existing plant and the residual issues having a cascading effect on the same.
- ***Limited interactions between the Project facility and the local community:*** based on the FGD with the community at *Dakshin Choto Monika* and *Dakshin Kutba* which is located very close of the Project site, it was reported that the Project construction phase did not have any major or significant interaction with the local population or the resource capital within the village. The only level of interaction was a positive impact in terms of labour employment.
- ***Limited restrictions on access to any community resource around the Project site:*** the local community reported that due to the establishment of the BPDB Project, no restrictions as such were imposed in terms of access to Char land, grazing land, the river or any similar community resource. It was observed as well as conveyed that the land around the unused jetty area and adjacent to the boundary wall of the Project site was being used yearly for growing of pulses and rice and for grazing purposes. They also reported that the current land procurement for NBBL plant may further reduce grazing land in the two villages
- ***Escalation of local land prices:*** it was reported by the community that the land prices around the Project area have increased significantly due to the establishment of the existing BPDB plant. It is expected to rise further with the advent of this Project.
- ***Disruption of boat movement and fishing activities due to temporary Jetty:*** the local fishermen representatives were of the opinion that the use of the Jetty area for vessel and material movement would result in a negative impact on the local community. This negative impact is likely to

be resultant from a restriction on boat movement and use of nets, restriction on fishing activities during certain time periods and a decline in fish population and catch due to churning of river bed and siltation. Resultant from this, the representatives were of the opinion that the use of the Jetty by the project should be undertaken during the pre-monsoons and outside of the spawning period of the important species.

## 8.6

### *PUBLIC CONSULTATION MEETING FOR ESIA DISCLOSURE*

In addition to focus group discussions (FGDs), community meetings and consultations with key informants – a Public Consultation Meeting was held on 6th March, 2017 at Upazila Auditorium, Borhanuddin Upazila Office, Borhanuddin to disclose the key findings, impacts and proposed mitigation of the project. The meeting was presided by Upazila Nirbahi Officer (UNO), and attended by representatives from other Government Departments, Ward Councilors Borhanuddin Upazila and Union Parishads, Teachers, eminent citizens, senior citizens and NGO representatives. The people were notified about the meeting through invitation letters issued by the Project Proponent that outlined the purpose of the meeting along with date, time and venue; notices were also put up at prominent places in Upazila Office in advance.

A presentation was made on the Project, Nutan Bidyut (Bangladesh) Ltd. (NBBL) and on findings of the ESIA conducted followed by question and answer session. The Q&A session witnessed some technical questions being asked by the participants – especially on cumulative impact on environment due to operations of two similar plants, availability of sufficient natural gas from the gas field for running of two power plants, safety arrangements in case of fire hazards or other accidents, etc. This ESIA report is updated with the key points of discussion including issues raised and suggestions provided by different stakeholders during the public consultation. The details of Public Consultation Meeting along with photographs and list of participants is provided in **Annexure W**.

## 8.7

### *WAY FORWARD*

The effectiveness of the ESIA is directly related to the degree of continuing involvement of those affected directly or indirectly by the Project. During the preparatory stage, consultations were held at local, sub district and district level. Several additional rounds of consultations with stakeholders will be planned during construction and operation phase of the Project.

Continued information disclosure and consultation process can either be done internally by the Project proponent or through engaging some outside agency on behalf of them. Should consultation be undertaken using internal resources by the Project proponent, an assessment of internal capacity and expertise should be undertaken. If the capacity is not available, the Project proponent should engage an external agency and gradually build up internal capacity by

working alongside of that agency. This will help them in developing internal capacity and maintaining continued consultation process through the Project life cycle.

Please refer to *Annexure X-1* for a detailed Stakeholder Engagement Plan and Grievance Redressal Mechanism.

This section on Risk Assessment (RA) aims to provide a systematic analysis of the major risks that may arise as a result of the proposed dual fuel based (natural gas and HSD) combined cycle power plant (CCPP) in Bhola, Bangladesh. The RA process outlines rational evaluations of the identified risks based on their significance and provides the outline for appropriate preventive and risk mitigation measures. The output of the RA will contribute towards strengthening of the Emergency Response Plan (ERP) in order to prevent damage to personnel, infrastructure and receptors in the immediate vicinity of the plant. Additionally, the results of the RA can also provide valuable inputs for keeping risk at As Low As Reasonably Practicable (ALARP) and arriving at decisions for mitigation of high risk events.

The following section describes the objectives, methodology of the risk assessment study and assessment for each of the potential risk separately. This includes identification of major hazards, hazard screening and ranking, frequency and consequence analysis for major hazards. The hazards have been quantitatively evaluated through a criteria base risk evaluation matrix. Risk mitigation measures to reduce significant risks to acceptable levels have also been recommended as a part of the risk assessment study.

## 9.1

### **RA STUDY OBJECTIVE**

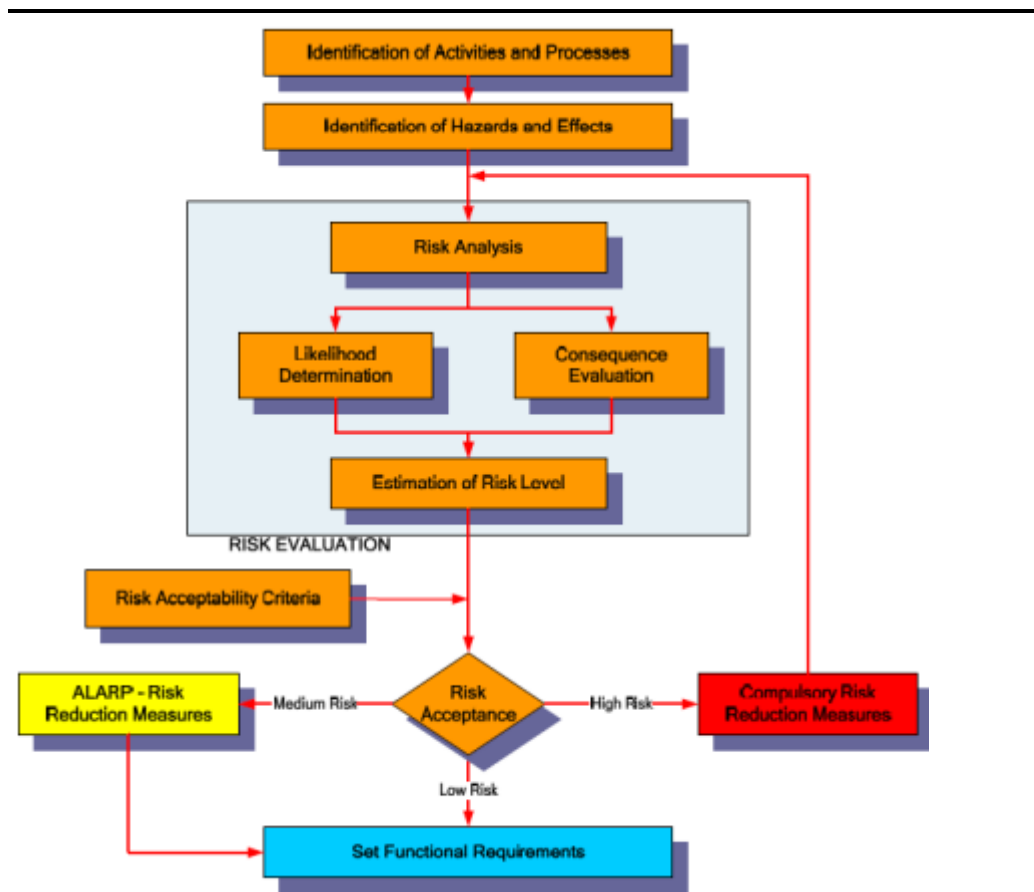
The overall objective of this RA with respect to the proposed project involves identification and evaluation of major risks, prioritizing risks identified based on their hazard consequences and using the outcome to guide and strengthen both onsite and offsite ERP. Hence in order to ensure effective management of any emergency situations that may arise from failure of High Speed Diesel (HSD) storages and natural gas supply pipelines, the following specific objectives need to be achieved.

- Identify potential risk scenarios that may arise from storage of diesel (including its unloading operations) and supply of natural gas via pipelines;
- Review existing information and historical databases to arrive at possible likelihood of such risk scenarios;
- Predict the consequences of such potential risk scenarios and if consequences are observed to be high, establish the same through application of quantitative simulations; and
- Recommend feasible preventive and risk mitigation measures as well as provide inputs for strengthening of the project Emergency Response Plan (ERP).

The risk assessment process is primarily based on likelihood of occurrence of the risks identified and their possible hazard consequences particularly being evaluated through hypothetical accident scenarios. With respect to the proposed project, major risks viz. leaks and rupture of storage tanks and pipelines been assessed and evaluated through a risk matrix generated to combine the risk severity and likelihood factor. Risk associated with the proposed dual fuel based CCPP project have been determined semi-quantitatively as the product of likelihood/probability and severity/consequence by using order of magnitude data (*risk ranking = severity/consequence factor X likelihood/probability factor*). Significance of such project related risks was then established through their classification as high, medium, low, very low depending upon risk ranking.

The risk matrix is widely accepted as standardized method of risk assessment and is preferred over purely quantitative methods, given that it's inherent limitations to define a risk event is certain. Application of this tool has resulted in the prioritization of the potential risks events for the existing operations and proposed expansion thus providing the basis for drawing up risk mitigation measures and leading to formulation of plans for risk and emergency management. The overall approach is summarized below in Figure 9.1.

Figure 9.1 Risk Assessment Methodology



### 9.3

#### *SAFETY MEASURES FOR PROPOSED FLAMMABLE STORAGES & PIPELINE*

Adequate number of gas leak detection and fire detection system as per stipulated norms will be provided for the pipeline supply of natural gas. Gas flow measurement system with integrator and local/remote indication will also be installed.

The fuel oil storage is planned to be provided with firefighting facilities as per Oil Industry Safety Directorate (OISD) Standard 117. As per this OISD standard, 4 hours of fire water supply will be required for firefighting. The fire water will be stored in two steel cone roof tanks and same will be connected with centrifugal pump for supplying water to the fire water network. Fire hydrants and monitors are also proposed around tank farm for firefighting. Day tanks planned to be located at the power plant will also having firefighting arrangements as per OISD-117. The fire water will be supplied from the power plant fire water supply source.

For the fuel oil storage tanks, the storage and movement of fuels at the tank farm will be managed via combination of both manual and automatic tank gauging as mentioned in OISD-117. Based on proposed designs, all storage tanks on site will be provided with secondary containment and will be able to contain leaks and spills.

### 9.4

#### *SAFETY MEASURES FOR CHLORINE*

##### *Receipt and Unloading of Chlorine Tonners/Cylinders*

The chlorine tonners/cylinders to be lifted by using a hoist of sufficient capacity for the load in conjunction with a ton container lifting beam .A forklift of sufficient capacity can also be used. The tonners/cylinders to be always kept secured to prevent them from rolling.

##### *Storage Requirements*

The water treatment plant (WTP) building to be storing the chlorine tonners/cylinders will be designed and constructed to protect all elements of the chlorine system from fire hazards. All the containers to be kept segregated from flammable and oxidizing materials and from materials such as ammonia, sulfur dioxide, hydrocarbons, certain refrigerants and other materials that are reactive with chlorine. In case, flammable materials are stored or processed in the same building, a fire wall that meets the applicable fire and building code standards should be in place.

The chlorine storage areas/buildings to be equipped with gas detection equipment to monitor for any accidental chlorine releases. Chlorine detectors are to be designed and adequately maintained to warn personnel or to signal a remote, manned location in case of a leak. Proper maintenance will also include a written plan for a regular calibration of the monitoring equipment, including written documentation of periodic testing.

### *Operational Requirements*

The chlorine containers to be emptied in the gas phase, standing secured in an upright position. The containers to be set in a horizontal position with the valves placed in a vertical plane, delivering gas from the upper valve and liquid from the lower valve. When emptied in the liquid phase, a vaporizer should normally be used.

When discharging through a manifold, care shall be taken that all containers are at the same temperature, particularly when connecting a new container to the manifold. If there is a difference in the temperature of the liquid chlorine, it will be transferred by distillation from the warm to the cool container, and the cooler container may become completely filled with liquid. If this should occur and the container valve remains closed, hydrostatic pressure may cause bursting. For this reason, extra precautions to be observed when closing valves of containers connected to a manifold.

When chlorine is being absorbed in liquid, proper precautions will be taken to prevent suck-back of the liquid into the container when it becomes empty (due to a partial vacuum created); a barometric leg or vacuum breaking device or both to be installed in such a case.

## **9.5**

### ***HAZARD IDENTIFICATION***

The first stage in any risk assessment is to identify the potential incidents that could lead to the release of a hazardous material from its normal containment and result in a major accident. This is achieved by a systematic review of the facilities to determine where a release of a hazardous material could occur from various parts of the installation.

The major hazards are generally one of three types: flammable, reactive and/or toxic. In this study, only flammable hazards are relevant involving loss of containment of diesel and leakage from natural gas pipeline. Flammable hazards may manifest as high thermal radiation from fires and overpressures following explosions that may cause direct damage, building collapse, etc. Flammable hazards are present throughout the facility and associated pipelines. Fires may occur if flammable materials are released to the atmosphere and ignition takes place.

Based on the result of this exercise, potential hazards that may arise due to proposed project were identified and a qualitative understanding of their probability and significance were obtained. Taking into account the applicability of different risk aspects the following hazards have been identified with respect to the proposed project which has been dealt in detail in the subsequent sections.

- Release of diesel from failure of loading/unloading line or hose and from storage tank leaks may lead to jet fire (from immediate ignition), pool fire and VCE (from delayed ignition);



- Accidental release of natural gas from pipelines leading to jet fire, flash fire or vapour cloud explosion (VCE); and
- Accidental release of chlorine from tonners leading to toxic vapour cloud dispersion.

### 9.5.1 *Hazards from Flammable Liquid Storages and Gas Pipelines*

There are a number of hazards that are present at the proposed project site that may result in injury to people or a fatality in more serious cases. This study is only concerned with ‘major hazards’, which are as follows:

- Jet fires associated with pipework failures;
- Hydrocarbon fires associated with tank failures;
- Storage tank fires;
- Vapour cloud explosions; and
- Flash fires.

Each of these hazards has been described below.

#### *Jet Fire*

Jet fires result from ignited releases of pressurized flammable gas or superheated/pressurized liquid. The momentum of the release carries the material forward in a long plume entraining air to give a flammable mixture. Jet fires only occur where the LNG is being handled under pressure or when handled in gas phase and the release is unobstructed.

#### *Pool Fires*

The principal type of hydrocarbon fire of interest in this study is a pool fire. If a liquid release has time to form a pool and is then ignited before the pool evaporates or drains away, then a pool fire results. Because they are less well aerated, pool fires tend to have lower flame temperatures and produce lower levels of thermal radiation than some other types of fire (such as jet fires); however, this means that they will produce more smoke. Although a pool fire can still lead to structural failure of items within the flame, this will take several times longer than in a jet fire. An additional hazard of pool fires is their ability to move. A burning liquid pool can spread along a horizontal surface or run down a vertical surface to give a running fire. Due to the presence of kerbs, slopes, drains and other obstacles; pool fire areas and directions can be unpredictable.

For this study, pool fires have been limited to the bund size used for a full bund fire; one-fourth of the bund size for small bund fire; and 100m pool diameter for unconfined fires.

### *Flash Fire*

Vapour clouds can be formed from the release of flashing liquids of pressurized flammable material as well as from non-flashing liquid releases where vapour clouds can be formed from the evaporation of liquid pools or from an overfilling of storage tanks or vessels.

Where ignition of a release does not occur immediately, a vapour cloud is formed and moves away from the point of origin under the action of the wind. This drifting cloud may undergo delayed ignition if an ignition source is reached, resulting in a flash fire if the cloud ignites in an unconfined area or vapour cloud explosion (VCE) if within confined area.

Flash fires are considered to be possible as a result of overfilling of storage tanks. Vapour from evaporating pools is not considered to result in flash fires due to slower evaporation rates. The cloud typically stays above the liquid pool and does not disperse significantly out of the bund limits. Should vapour be ignited it will most likely initiate a pool fire of the released pool.

### *Vapour Cloud Explosion*

If the generation of heat in a fire involving a vapour-air mixture is accompanied by the generation of pressure then the resulting effect is a vapour cloud explosion (VCE). The amount of overpressure produced in a VCE is determined by the reactivity of the gas, the strength of the ignition source, the degree of confinement of the vapour cloud, the number of obstacles in and around the cloud and the location of the point of ignition with respect to the escape path of the expanding gases.

## **9.5.2 Hazards from Chlorine<sup>1</sup>**

Chlorine is a highly toxic chemical being extremely irritating to the mucous membranes of the eyes and respiratory tract. It combines with moisture to liberate nascent oxygen and form hydrochloric acid. Both these substances, if present in quantity, cause inflammation of the tissues with which they come in contact. If the lung tissues are attacked, pulmonary edema may result.

The current OSHA standard for chlorine is a ceiling level of 1ppm averaged over a 15 minute period and an IDLH value of 10 ppm. NIOSH has recommended that the permissible exposure limit to be 0.5 ppm measured over a 15 minute period. Overexposure to concentrations moderately above the TLV of 1 ppm irritates the eyes and respiratory tract. Chlorine is extremely irritant to the mucous membrane of the eyes at 3ppm and respiratory tract; 15 ppm causes immediate irritation of the throat. Concentrations of 50 ppm are

<sup>1</sup> NIOSH – Occupational Health Guideline for Chlorine

Dangerous Properties of Industrial Materials - Handbook of Dangerous Materials by N. Irving Sax

dangerous for even short exposures. Concentrations of about 400 ppm and beyond are generally fatal over 30 minutes, and at 1,000 ppm and above, fatality ensues within only a few minutes.

The physiological effects of various concentrations of chlorine gas are shown in Table 9.1.

**Table 9.1** *Effects of Chlorine at Various Concentrations*

Sl. No	Effects	Concentration of Chlorine in Air (ppm)
1	NIOSH-TLV	0.5
2	OSHA PEL	1.0
3	Extremely irritating to the mucous membrane of the eyes	3.0
4	Immediately Dangerous to Life or Health (IDLH)	10.0
5	Concentration causing immediate irritation of throat	15.0
6	Concentration dangerous for even short exposure	50
7	Fatal, even if the exposure is brief	1000

Source: NIOSH - Occupational Health Guideline for Chlorine and Handbook of Dangerous Materials by N. Irving Sax

The frequency analysis of the hazards identified with respect to the proposed project was undertaken to estimate the likelihood of their occurrences during the project life cycle. Hazard frequencies in relation to the proposed project were estimated based on the analysis of historical accident frequency data and professional judgment. Based on the range of probabilities arrived at for different potential hazards that may be encountered with respect to the storage of diesel, supply of natural gas and handling of chlorine, the following frequency categories and criteria have been defined (Refer Table 9.2).

**Table 9.2** *Frequency Categories and Criteria*

Likelihood Ranking	Criteria Ranking (cases/year)	Frequency Class
5	Likely to occur often in the life of the project, with a probability greater than $10^{-1}$	Frequent
4	Will occur several times in the life of project, with a probability of occurrence less than $10^{-1}$ , but greater than $10^{-2}$	Probable
3	Likely to occur sometime in the life of a project, with a probability of occurrence less than $10^{-2}$ , but greater than $10^{-3}$	Occasional/Rare
2	Unlikely but possible to occur in the life of a project, with a probability of occurrence less than $10^{-3}$ , but greater than $10^{-6}$	Remote
1	So unlikely it can be assumed that occurrence may not be experienced, with a probability of occurrence less than $10^{-6}$	Improbable

Source: Guidelines for Developing Quantitative Safety Risk Criteria – Centre for Chemical Process and Safety

### 9.6.1 *Frequency Analysis – Diesel Storage*

The most credible scenario of a diesel tank will be pool fire. In order to determine the probability of a pool fire occurring, the failure rate needs to be modified by the probability of the material finding an ignition source. The probability of a pool fire occurring in the event of a release is therefore equal to the product of the failure rate and the probability of ignition. The frequency of the release scenarios identified in the *Section 9.8.1* is represented in Table 9.3 below. The ignition probability is dependent on a number of factors including the type of site, the release rate and the type of material released.

**Table 9.3** *Tank Failure Frequency*

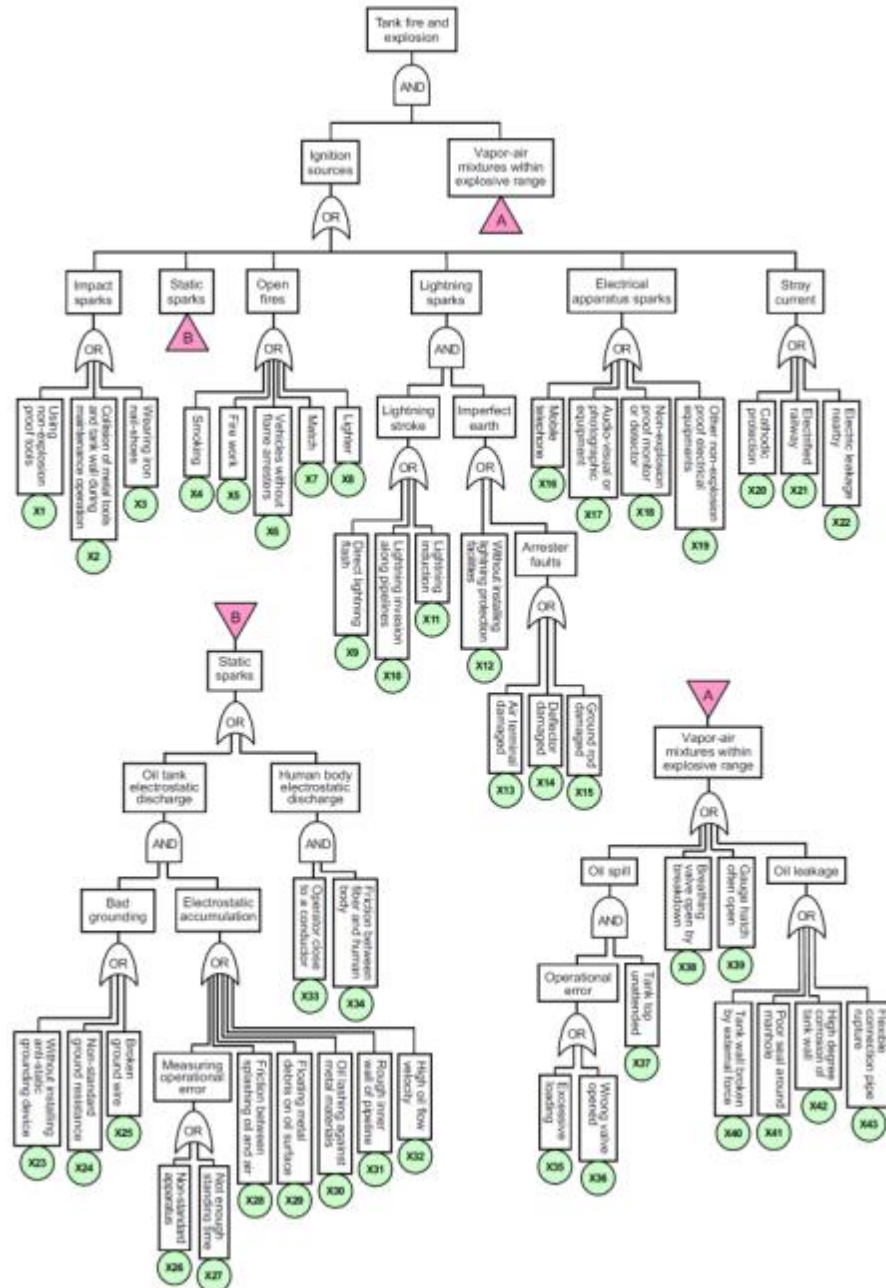
Sl. No	Type of Release	Failure Rate (per vessel per year)	Frequency
1	Catastrophic tanks failure	$5.0 \times 10^{-6}$	Remote
2	Small bund fire	$9.0 \times 10^{-5}$	Remote
3	Large bund fire	$6.0 \times 10^{-5}$	Remote

Source: OGP Risk Assessment Data Directory Report No 434 – 3, March 2010, Section 2 – Summary of Recommended Data

## Event Tree Analysis

Event tree analysis (ETA) is used to model the evolution of an event from the initial release through to the final outcome such as jet fire, fireball, flash fire etc. This may depend on factors such as whether immediate or delayed ignition occurs, or whether there is sufficient congestion to cause a vapour cloud explosion. The event tree for fire and explosion for an oil storage tank is shown in Figure 9.2.

Figure 9.2 Event Tree Analysis - Tank Failure



Source: Fuzzy Fault Tree Analysis for Fire and Explosion in Crude Oil Tanks – Daqing Wang, Peng Zhang and Liqiong Chen, Journal of Loss Prevention in the Process Industries

## 9.6.2

### *Frequency Analysis - Pipeline*

An effort has also been made to understand the primary failure frequencies of pressurised natural gas pipeline to be supplied to the site to serve as a fuel source. Based on the European Gas Pipeline Incident Data Group (EGIG) database the evolution of the primary failure frequencies over the entire period and for the last five years has been provided in Table 9.4 below.

**Table 9.4** *Primary Gas Pipeline Failure Frequency*

Period	No. of Incidents	Total System Exposure (km.yr)	Primary failure frequency (1000 km.yr)
1970-2007	1173	3.15.10 <sup>6</sup>	0.372
1970-2010	1249	3.55.10 <sup>6</sup>	0.351
1970-2013	1309	3.98.10 <sup>6</sup>	0.329
1974-2013	1179	3.84.10 <sup>6</sup>	0.307
1984-2013	805	3.24.10 <sup>6</sup>	0.249
1994-2013	426	2.40.10 <sup>6</sup>	0.177
2004-2013	209	1.33.10 <sup>6</sup>	0.157
2009-2013	110	0.70.10 <sup>6</sup>	0.158

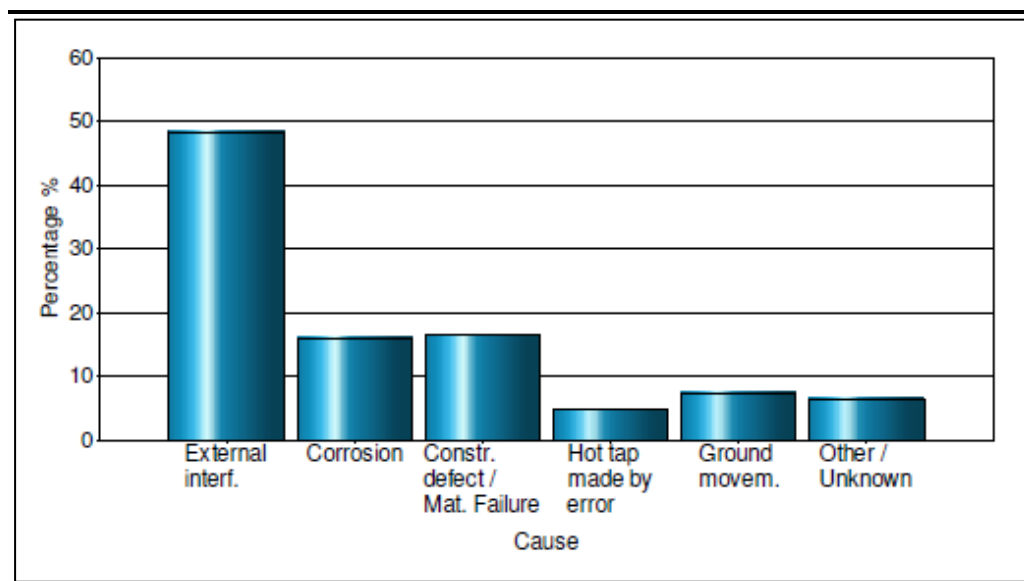
Source: 9th EGIG Report

As referred in the above table the overall failure frequency (0.33) of the entire period (1970-2013) is slightly lower than the failure frequency of 0.35 reported in the 8<sup>th</sup> EGIG report (1970-2010). The failure frequency of the last 5 years was found to be 0.16 per 1000km.year, depicting an improved performance over the recent years.

#### Incident Causes

Gas pipeline failure incidents can be attributed to the following major causes viz. external interference, construction defects, corrosion (internal & external), ground movement and hot tap. The distribution of incidents with cause has been presented in the Figure 9.3 below.

**Figure 9.3 Gas Pipeline Failure - Distribution of Incident & Causes**



Source: 8<sup>th</sup> EGIG Report

The interpretation of the aforesaid figure indicated external interference as the major cause of pipeline failure contributing to about 48.4% of the total failure incidents followed by construction defects (16.7%) and corrosion related problems (16.1%). Ground movement resulting from seismic disturbance, landslides, flood etc. contributed to only 7.4% of pipeline failure incident causes.

Review of the 9<sup>th</sup> EGIG report indicates that primary failure frequency varies with pipeline diameter, and the same has been presented in Table 9.5 below.

**Table 9.5 Primary Failure Frequency based on Diameter Class (1970-2013)**

Nominal Diameter (inch)	Primary failure frequency (per km.yr)		
	Pinhole/Crack	Hole	Rupture
diameter < 5"	4.45 X 10 <sup>-4</sup>	2.68 X 10 <sup>-4</sup>	1.33 X 10 <sup>-4</sup>
5" ≤ diameter < 11"	2.80 X 10 <sup>-4</sup>	1.97 X 10 <sup>-4</sup>	6.40 X 10 <sup>-5</sup>
11" ≤ diameter < 17"	1.27 X 10 <sup>-4</sup>	0.98 X 10 <sup>-4</sup>	4.10 X 10 <sup>-5</sup>
17" ≤ diameter < 23"	1.02 X 10 <sup>-4</sup>	5.00 X 10 <sup>-5</sup>	3.40 X 10 <sup>-5</sup>
23" ≤ diameter < 29"	8.50 X 10 <sup>-5</sup>	2.70 X 10 <sup>-5</sup>	1.20 X 10 <sup>-5</sup>
29" ≤ diameter < 35"	2.30 X 10 <sup>-5</sup>	5.00 X 10 <sup>-6</sup>	1.40 X 10 <sup>-5</sup>
35" ≤ diameter < 41"	2.30 X 10 <sup>-5</sup>	8.00 X 10 <sup>-6</sup>	3.00 X 10 <sup>-6</sup>
41" ≤ diameter < 47"	7.00 X 10 <sup>-6</sup>	-	-
diameter ≥ 47"	6.00 X 10 <sup>-6</sup>	6.00 X 10 <sup>-6</sup>	6.00 X 10 <sup>-6</sup>

Source: 9<sup>th</sup> EGIG Report

The pipeline failure frequency viz. leaks or rupture for the natural gas pipeline has been computed based on the aforesaid table. For pipeline with diameter varying within 11 to 17 inches, the probability of pinhole is estimated to be **1.27 x 10<sup>-4</sup> per km year**, while full bore rupture is considered to be **4.10 x 10<sup>-5</sup> per km year**. **This is considered for estimating failure probability of the**



**natural gas pipeline having a 12 inch diameter which supplies to metering skid onsite. (Refer Table 9.6 below).**

**Table 9.6 Natural Gas Pipeline - Failure Frequency**

Sl. No	Pipeline Failure Case	EGIG Failure Frequency (per km.year)	Avg. Pipeline Length (km)	Project Pipeline Failure Frequency (per year)	Frequency
1	Natural Gas Pipeline Rupture	$4.10 \times 10^{-5}$	7.0	$2.87 \times 10^{-4}$	Remote
2	Natural Gas Pipeline Leak	$1.27 \times 10^{-4}$	7.0	$8.89 \times 10^{-4}$	Remote

Thus the probability of pipeline leak and rupture with respect to the pipeline transportation of natural gas as fuel to the site is identified to be as “Remote” (Refer Table 9.6).

*Pipeline Failure – Ignition Probability*

The ignition probability of natural gas pipeline failure (rupture & leaks) with respect to the proposed project is derived based on the following equations as provided in the IGEM/TD/2 standard

$$\left. \begin{aligned} P_{ign} &= 0.0555 + 0.0137pd^2; \text{ for } 0 \leq pd^2 \leq 57 \\ \text{(For pipeline ruptures)} \\ P_{ign} &= 0.81; \text{ for } pd^2 > 57 \end{aligned} \right\}$$

$$\left. \begin{aligned} P_{ign} &= 0.0555 + 0.0137(0.5pd^2); \text{ for } 0 \leq 0.5pd^2 \leq 57 \\ \text{(For pipeline leaks)} \\ P_{ign} &= 0.81; \text{ for } 0.5pd^2 > 57 \end{aligned} \right\}$$

**Where:**

- P<sub>ign</sub>** = **Probability of ignition**
- p** = **Pipeline operating pressure (bar)**
- d** = **Pipeline diameter (m)**

The ignition probability of natural gas release from a leak/rupture of 12inch natural gas pipeline is calculated based on the above equations utilizing the following input parameters as discussed below.

*Natural Gas Pipeline*

Normal Pipeline Inlet Pressure (bar) = p= 41.3 bar

Pipeline diameter = d = 12 inch or 0.30 m

For pipeline rupture  $pd^2 = (41.3) \times (0.30)^2 = 3.717$

For pipeline leak  $0.5 pd^2 = 0.5 \times (41.3) \times (0.30)^2 = 1.858$

Since  $0 \leq pd^2 \leq 57$  and  $0 \leq 0.5pd^2 \leq 57$ , the following equation has been utilized for deriving the ignition probability for failure.

$$P_{\text{ign for pipeline rupture}} = 0.0555 + 0.0137pd^2 = 0.0555 + 0.0137 (3.717) = 0.10$$

$$P_{\text{ign for pipeline leak}} = 0.0555 + 0.0137(0.5pd^2) = 0.0555 + 0.0137 (1.858) = 0.08$$

The probability of ignition for an accidental release of natural gas from pipeline supplying the site is presented in Table 9.7 below:

**Table 9.7** *Natural Gas Pipeline –Jet Fire Probability*

Sl. No	Pipeline Failure Case	Project Pipeline Failure Frequency (per year)	Ignition Probability	Jet Fire Probability
1	Natural Gas Pipeline Leak	$1.27 \times 10^{-4}$	0.08	$1.01 \times 10^{-5}$
2	Natural Gas Pipeline Rupture	$4.10 \times 10^{-5}$	0.10	$0.41 \times 10^{-5}$

Hence from the above table it can be concluded that ignition probability of natural gas that may be released from the supply pipeline due to any accidental event is considered to be unlikely.

### 9.6.3 *Frequency Analysis – Chlorine Storage Tanks*

An effort has been made to understand the causal factors for release of chlorine from tonners based on review of the thesis on “*Consequence Modelling, Vulnerability Assessment, and Fuzzy Fault Tree Analysis of Hazardous Storages in an Industrial Area*”<sup>1</sup>. The thesis indicates that release of chlorine from storage tanks can occurs following circumstances:

- Corrosion
- Exothermic chemical reaction
- Exposure to external heat
- Insulation failure and subsequent temperature rise
- Failure of level indicators/ alarm devices

The failure frequency of chlorine tonners is established based on review of the *UK HSE Database - Failure Rate and Event Data for use within Risk Assessments (28/06/2012)*. The failure rates for chlorine storages are presented in Table 9.8 below.

<sup>1</sup>Renjith V.R. - Division of Safety and Fire Engineering, School of Engineering, Cochin University of Science and Technology

**Table 9.8 Chlorine Storage - Failure Rates based on Type of Release**

Sl. No	Type of Release	Failure Rate (per storage per year)	Frequency
1	Catastrophic	$4.0 \times 10^{-6}$	Remote
2	50mm diameter hole	$5.0 \times 10^{-6}$	Remote
3	25mm diameter hole	$5.0 \times 10^{-6}$	Remote
4	13mm diameter hole	$1.0 \times 10^{-5}$	Remote
5	6mm diameter hole	$4.0 \times 10^{-5}$	Remote

Source: UK HSE Database

## 9.7 CONSEQUENCE ANALYSIS

In parallel with the frequency analysis, hazard prediction / consequence analysis exercises were undertaken to assess the likely impact of project related risks on onsite personnel, infrastructure and environment. In relation to the proposed project as well as the existing activities have been considered, the estimation of the consequences for each possible event has been based either on accident frequency, consequence modeling or professional judgment, as appropriate. Overall, the consequence analysis takes into account the following aspects:

- Nature of impact on environment and community;
- Occupational health and safety;
- Asset and property damage;
- Corporate image; and
- Timeline for restoration of property damage.

The following criteria for consequence rankings (Refer Table 9.9) have been drawn up in context of the possible consequences of the risk events that may occur during the proposed project operations:

**Table 9.9 Severity Categories and Criteria**

Consequence	Ranking	Criteria Definition
Catastrophic	5	<ul style="list-style-type: none"> <li>• Multiple fatalities/permanent total disability to more than 50 persons.</li> <li>• Net negative financial impact of &gt;10 crores</li> <li>• International media coverage</li> <li>• Loss of corporate image and reputation</li> </ul>
Major	4	<ul style="list-style-type: none"> <li>• Single fatality/permanent total disability to one or more persons</li> <li>• Net negative financial impact of 5 -10 crores</li> <li>• National stakeholder concern and media coverage.</li> </ul>
Moderate	3	<ul style="list-style-type: none"> <li>• Short term hospitalization &amp; rehabilitation leading to recovery</li> <li>• Net negative financial impact of 1-5 crores</li> <li>• State wide media coverage</li> </ul>
Minor	2	<ul style="list-style-type: none"> <li>• Medical treatment injuries</li> <li>• Net negative financial impact of 0.5 - 1 crore</li> <li>• Local stakeholder concern and public attention</li> </ul>

Consequence	Ranking	Criteria Definition
Insignificant	1	<ul style="list-style-type: none"> <li>• First Aid treatment</li> <li>• Net negative financial impact of &lt;0.5 crores.</li> <li>• No media coverage</li> </ul>

### Risk Evaluation

Based on ranking of likelihood and frequencies, each identified hazard has been evaluated based on the likelihood of occurrence and the magnitude of consequences. The significance of the risk is expressed as the product of likelihood and the consequence of the risk event, expressed as follows:

$$\text{Significance} = \text{Likelihood} \times \text{Consequence}$$

The Table 9.10 below illustrates all possible product results for the five likelihood and consequence categories while the Table 9.11 assigns risk significance criteria in three regions that identify the limit of risk acceptability. Depending on the position of the intersection of a column with a row in the risk matrix, hazard prone activities have been classified as low, medium and high thereby qualifying for a set of risk reduction / mitigation strategies.

**Table 9.10 Risk Matrix**

		Likelihood →					
		Frequent	Probable	Unlikely	Remote	Improbable	
		5	4	3	2	1	
Consequence ↑	Catastrophic	5	25	20	15	10	5
	Major	4	20	16	12	8	4
	Moderate	3	15	12	9	6	3
	Minor	2	10	8	6	4	2
	Insignificant	1	5	4	3	2	1

**Table 9.11 Risk Criteria and Action Requirements**

S.N.	Risk Significance	Criteria Definition & Action Requirements
1	High (16 - 25)	"Risk requires attention" – Project HSE Management need to ensure that necessary mitigation are adopted to ensure that possible risk remains within acceptable limits
2	Medium (10 - 15)	"Risk is tolerable" – Project HSE Management needs to adopt necessary measures to prevent any change/modification of existing risk controls and ensure implementation of all practicable controls.
3	Low (5 - 9)	"Risk is acceptable" – Project related risks are managed by well-established controls and routine processes/procedures. Implementation of additional controls can be considered.
4	Very Low (1 - 4)	"Risk is acceptable" – All risks are managed by well-established controls and routine processes/procedures. Additional risk controls need not to be considered

## 9.7.1

### Consequence Analysis – Tankages

The main hazards associated with the storage and handlings of fuels are pool fires resulting from the ignition of released material as well as explosions and Flash fires resulting from the ignition of a flammable cloud formed in the event of tank overfilling. The hazards may be realised following tank overfilling and leaks/failures in the storage tank and ancillary equipment such as transfer pumps, metering equipment, etc. all of which can release significant quantities of flammable material on failure.

The **Section 9.8.1** had previously provided an explanation of the events which may occur as a result of release of flammable material, followed by ignition.

#### Bulk Storage Tank Scenarios

In addition to overfill, the scenarios considered for the diesel storage tanks were partial/local failures and cold catastrophic failures. Factors that have been identified as having an effect on the integrity of tanks are related to design, inspection, maintenance, and corrosion<sup>1</sup>. The following representative scenarios for the tanks were considered (Refer **Table 9.12**).

**Table 9.12 Diesel Storage Tank – Risk Modelling Scenarios**

Sl. No	Tank	Tank Diameter (m)	Tank Height (m)	Tank Volume (KL)	Accident Scenario	Threat Modelled
1		21.0	15.0	5192	5% release and ignition of total mass	Pool Fire
2	Diesel Tank	21.0	15.0	5192	15% release and ignition of total mass	Pool Fire
3		21.0	15.0	5192	50% release and ignition of total mass	Pool Fire VCE

The diesel storage tank failure risk scenarios have been modeled using ALOHA and interpreted in terms of Thermal Radiation Level of Concern (LOC) encompassing the following threshold values (measured in kilowatts per square meter) to create the default threat zones:

*Red: 10 kW/ (sq. m) -- potentially lethal within 60 sec;*

*Orange: 5 kW/ (sq. m) -- second-degree burns within 60 sec; and*

*Yellow: 2 kW/ (sq. m) -- pain within 60 sec*

For vapour cloud explosion, the following threshold level of concern has been interpreted in terms of blast overpressure as specified below:

*Red: 8.0 psi – destruction of buildings;*

*Orange: 3.5 psi – serious injury likely; and*

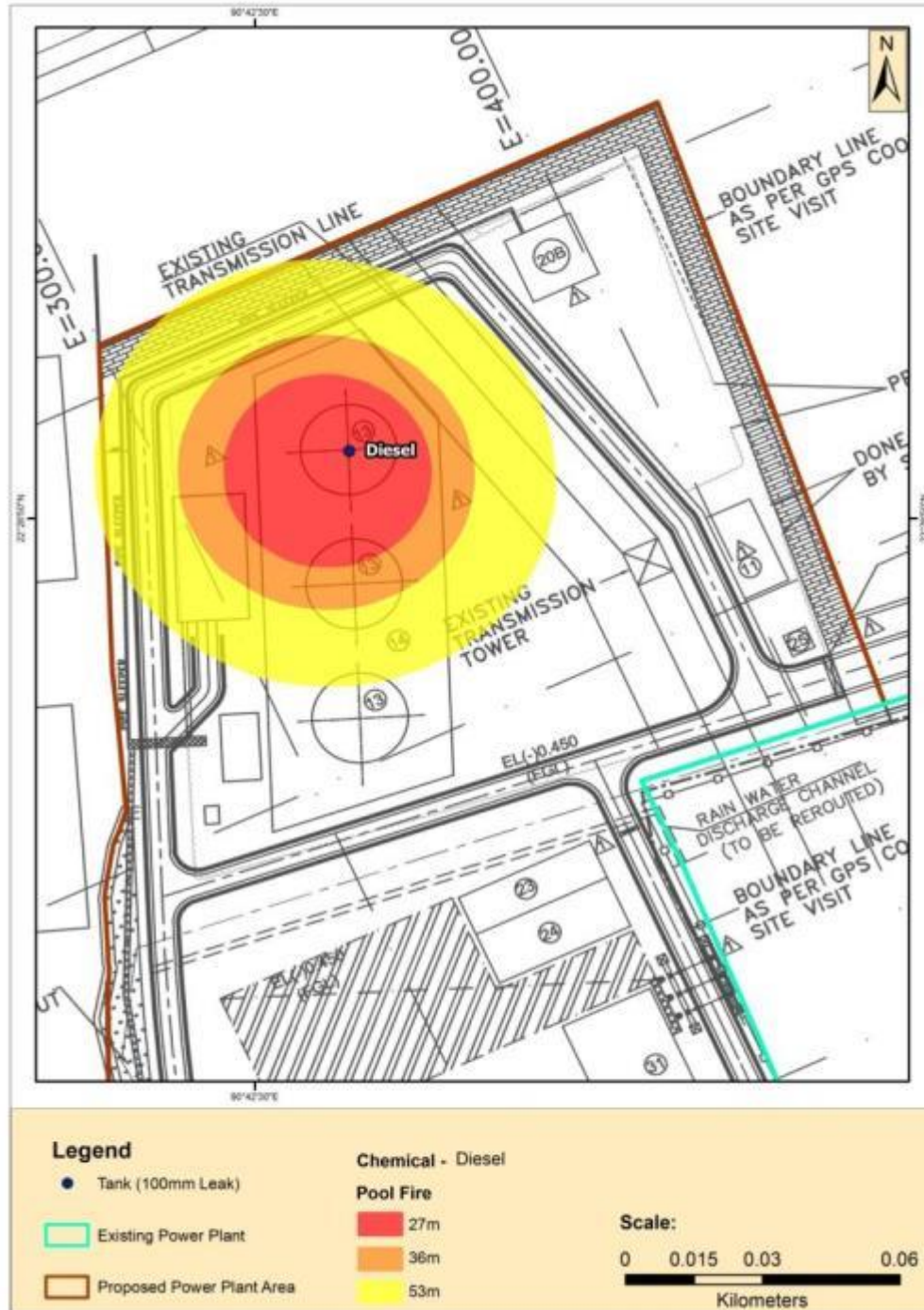
<sup>1</sup> AEA Technology, HSE Guidance Document

Yellow: 1.0 psi – shatters glass

Scenario 1: Diesel Storage Tank Failure – 5% Mass Release & Ignition

The pool fire threat zone plot for 5% release and ignition of diesel from storage tank failure is represented in Figure 9.4 below.

Figure 9.4 Threat Zone Plot -5% Mass Release & Ignition of Diesel Tank



Source: ALOHA

## THREAT ZONE:

Threat Modeled: Thermal radiation from pool fire

Red : 27 meters --- (10.0 kW/ (sq. m) = potentially lethal within 60 sec)

Orange: 36 meters --- (5.0 kW/ (sq. m) = 2nd degree burns within 60 sec)

Yellow: 53 meters --- (2.0 kW/ (sq. m) = pain within 60 sec)

**The worst hazard for 5% release and ignition of diesel from storage tank failure will be experienced to a maximum radial distance of 27m from the source with potential lethal effects within 1 minute.**

*Scenario 2: Diesel Storage Tank Failure – 15% Mass Release & Ignition*

The pool fire threat zone plot for 15% release and ignition of diesel from storage tank failure is represented in in Figure 9.5 below.



Figure 9.5 Threat Zone Plot -15% Mass Release & Ignition of Diesel Tank



Source: ALOHA

### THREAT ZONE:

Threat Modeled: Thermal radiation from pool fire

Red : 66 meters --- (10.0 kW/ (sq. m) = potentially lethal within 60 sec)

Orange: 92 meters --- (5.0 kW/ (sq. m) = 2nd degree burns within 60 sec)

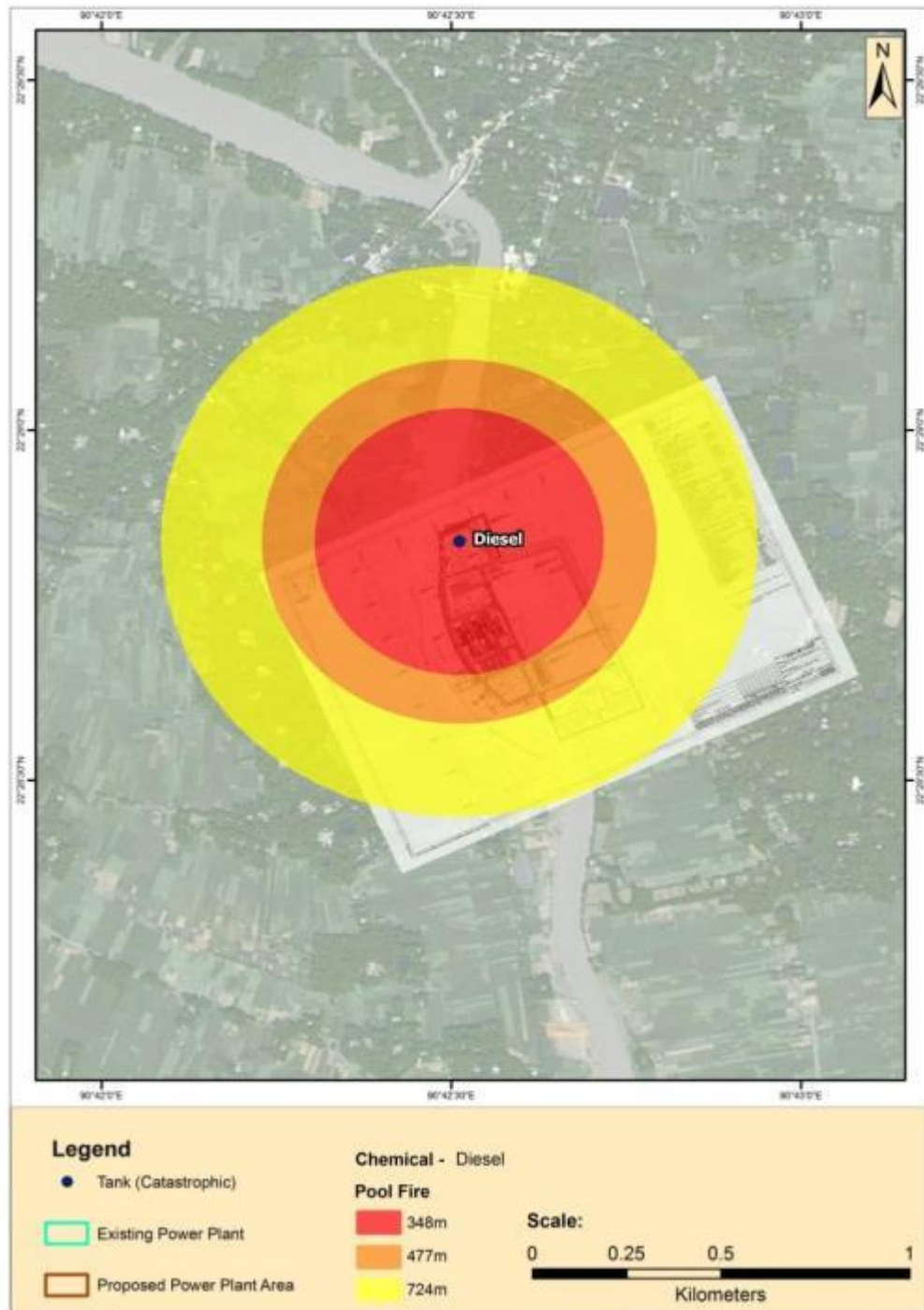
Yellow: 142 meters --- (2.0 kW/ (sq. m) = pain within 60 sec)

The worst hazard for 15% release and ignition of diesel from storage tank failure will be experienced to a maximum radial distance of 66m from the source with potential lethal effects within 1 minute.

*Scenario 3: Diesel Storage Tank Failure – 50% Mass Release & Ignition*

The pool fire threat zone plot for 50% release and ignition of diesel from storage tank failure is represented in *Figure 9.6* below.

**Figure 9.6** *Threat Zone Plot –50% Mass Release & Ignition of Diesel Tank*



Source: ALOHA

## THREAT ZONE:

Threat Modeled: Thermal radiation from pool fire

Red : 348 meters --- (10.0 kW/ (sq. m) = potentially lethal within 60 sec)

Orange: 477 meters --- (5.0 kW/ (sq. m) = 2nd degree burns within 60 sec)

Yellow: 724 meters --- (2.0 kW/ (sq. m) = pain within 60 sec)

**The worst hazard for 50% release and ignition of diesel from storage tank failure will be experienced to a maximum radial distance of 348m from the source with potential lethal effects within 1 minute.**

For VCE modelled for catastrophic failure of diesel storage tank, the LOC level was never exceeded

## THREAT ZONE:

Threat Modeled: Overpressure (blast force) from vapor cloud explosion

Type of Ignition: ignited by spark or flame

Level of Congestion: uncongested

Model Run: Heavy Gas

Red : LOC was never exceeded --- (8.0 psi = destruction of buildings)

Orange: LOC was never exceeded --- (3.5 psi = serious injury likely)

Yellow: LOC was never exceeded --- (1.0 psi = shatters glass)

For calculating the risk significance of diesel storage failure, the likelihood ranking is considered to be "2" as the failure probability for such failure is computed to be  $\sim 5 \times 10^{-6}$  per year. With respect to consequence ranking, for the aforesaid incident it has been identified to be as "4" given for a worst case scenario lethal effects is likely to be experienced within a maximum radial zone  $\sim 350$  meters. However, considering that isolated diesel storages will be equipped appropriate state of the art process and fire safety controls in consistent with OISD-117 requirements, the risk is likely to be less significant.

Further in consistent Bangladesh Petroleum Rules 1937, necessary safety consideration has been made in storage tank design so that adequate safe distance ( $>6.0$  m) is maintained with the existing power transmission line.

### *Risk Ranking – Diesel Tank Failure (Worst Case Scenario)*

Likelihood ranking	2	Consequence ranking	4
Risk Ranking & Significance = 8 i.e. "Low" i.e. Risk is Acceptable and can be managed through use of existing controls with the option for installation of additional controls, if necessary.			

Domino effect has not been considered taking into account the tank designing wherein they are adequately spaced and equipped with appropriate safety

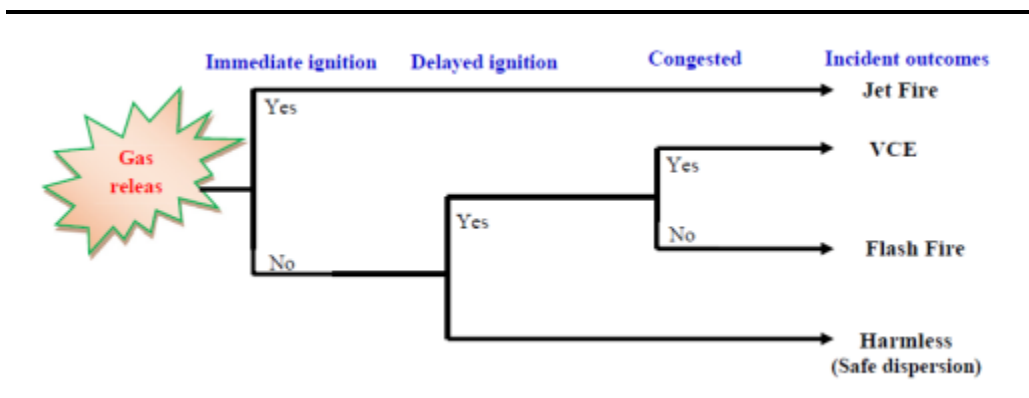
controls. Further review of the site plan reveals that the diesel storage tanks are located north abutting the project boundary of Bhola-II project. For the Scenario 1 and 2 modelled for diesel the risk countours for a maximum thermal radiation intensity of 10 kW/m<sup>2</sup> are limited to a radius of 27 m and 66 m radius respectively, which are well within the boundary of Bhola-II project. Only in the worst case scenario modelled for diesel the risk contours for a maximum thermal radiation intensity of 10kW/m<sup>2</sup> is spread upto a radius of 348m and can have domino effect on the gas receiving and metering stations of both Bhola II as well as Bhola-I power plants.

*Consequence Analysis – Pipelines*

Pipeline generally contains large inventories of oil or gas under high pressure; although accidental releases from them are remote they have the potential of catastrophic or major consequences if related risks are not adequately analysed or controlled. The consequences of possible pipeline failure is generally predicted based on the hypothetical failure scenario considered and defining parameters such as meteorological conditions (stability class), leak hole & rupture size and orientation, pipeline pressure & temperature, physicochemical properties of chemicals released etc.

In case of pipe rupture containing highly flammable natural gas, an immediate ignition will cause a jet fire. Flash fires can result from the release of natural gas through the formation of a vapour cloud with delayed ignition and a fire burning through the cloud. A fire can then flash back to the source of the leak and result in a jet fire. Flash fires have the potential for offsite impact as the vapour clouds can travel considerable distances downwind of the source. Explosions can occur when a flammable gas cloud in a confined area is ignited; however where vapour cloud concentration of released material is lower than Lower Flammability Limit (LFL), consequently the occurrence of a VCE is highly unlikely. VCE, if occurs may result in overpressure effects that become more significant as the degree of confinement increases (Refer Figure 9.7).Therefore, in the present study, only the risks of jet fires for the below scenarios have been modelled and calculated.

**Figure 9.7** *Natural Gas Release – Potential Consequences*



[Source: "Safety risk modelling and major accidents analysis of hydrogen and natural gas releases: A comprehensive risk analysis framework" - Iraj Mohammadfam, Esmaeil Zarei]

Based on the above discussion and frequency analysis as discussed in the earlier section, the following hypothetical risk scenarios (Refer Figure 9.8) have been considered for consequence analysis of the natural gas supply pipeline (12inch dia) of 7km length.

**Table 9.13 Pipeline Risk Modelling Scenarios**

Scenario	Pipeline	Accident Scenario	Design Pressure (bar)	Pipeline Temperature	Potential Risk
1	Natural Gas Supply Pipeline	Leak of 25mm dia	41.36	24°C	Jet Fire
2	Natural Gas Supply Pipeline	Leak of 50mm dia	41.36	24°C	Jet Fire
3	Natural Gas Supply Pipeline	Complete rupture	41.36	24°C	Jet Fire VCE

The pipeline failure risk scenarios have been modeled using ALOHA and interpreted in terms of Thermal Radiation Level of Concern (LOC) encompassing the following threshold values (measured in kilowatts per square meter) for natural gas (comprising of ~95% methane<sup>1</sup>) to create the default threat zones:

*Red: 10 kW/ (sq. m) -- potentially lethal within 60 sec;*

*Orange: 5 kW/ (sq. m) -- second-degree burns within 60 sec; and*

*Yellow: 2 kW/ (sq. m) -- pain within 60 sec.*

For vapour cloud explosion, the following threshold level of concern has been interpreted in terms of blast overpressure as specified below:

*Red: 8.0 psi – destruction of buildings;*

*Orange: 3.5 psi – serious injury likely; and*

*Yellow: 1.0 psi – shatters glass*

The risk scenarios modelled for natural gas pipeline has been presented below

<sup>1</sup> [https://www.naesb.org//pdf2/wgq\\_bps100605w2.pdf](https://www.naesb.org//pdf2/wgq_bps100605w2.pdf)

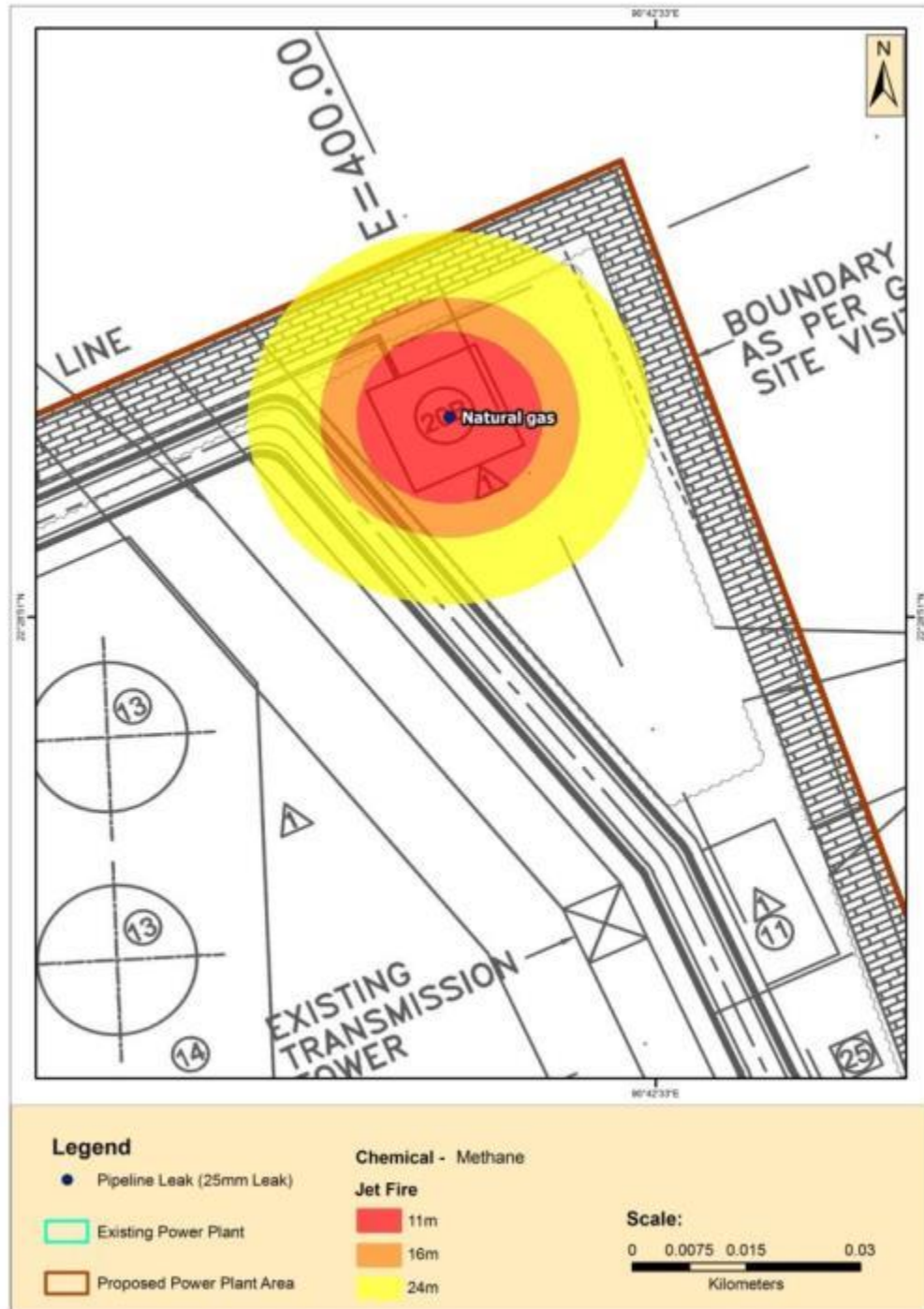
[http://www.google.co.in/url?sa=t&rct=j&q=&esrc=s&source=web&cd=18&ved=0ahUKewjF7MiDttPRAhVCMi8KHd7aD6cQFghrMBE&url=http%3A%2F%2Fwww.springer.com%2Fcd%2Fcontent%2Fdocument%2Fcd\\_downloaddocument%2F9781848828711-c1.pdf%3FSGWID%3D0-0-45-862344-p173918930&usg=AFQjCNEaJklfYKl3fRUdi6xiRYeW-FJb2A](http://www.google.co.in/url?sa=t&rct=j&q=&esrc=s&source=web&cd=18&ved=0ahUKewjF7MiDttPRAhVCMi8KHd7aD6cQFghrMBE&url=http%3A%2F%2Fwww.springer.com%2Fcd%2Fcontent%2Fdocument%2Fcd_downloaddocument%2F9781848828711-c1.pdf%3FSGWID%3D0-0-45-862344-p173918930&usg=AFQjCNEaJklfYKl3fRUdi6xiRYeW-FJb2A)



Scenario 1: Natural Gas Pipeline Leak (25mm dia)

The jet fire threat zone plot for release and ignition of natural gas from pipeline leak of 25mm dia is represented in Figure 9.8 below.

Figure 9.8 Threat Zone Plot - Natural Gas Pipeline Leak (25mm dia)



Source: ALOHA

**THREAT ZONE:**



Threat Modeled: Thermal radiation from jet fire

Red : 11 meters --- (10.0 kW/ (sq. m) = potentially lethal within 60 sec)

Orange: 16 meters --- (5.0 kW/ (sq. m) = 2nd degree burns within 60 sec)

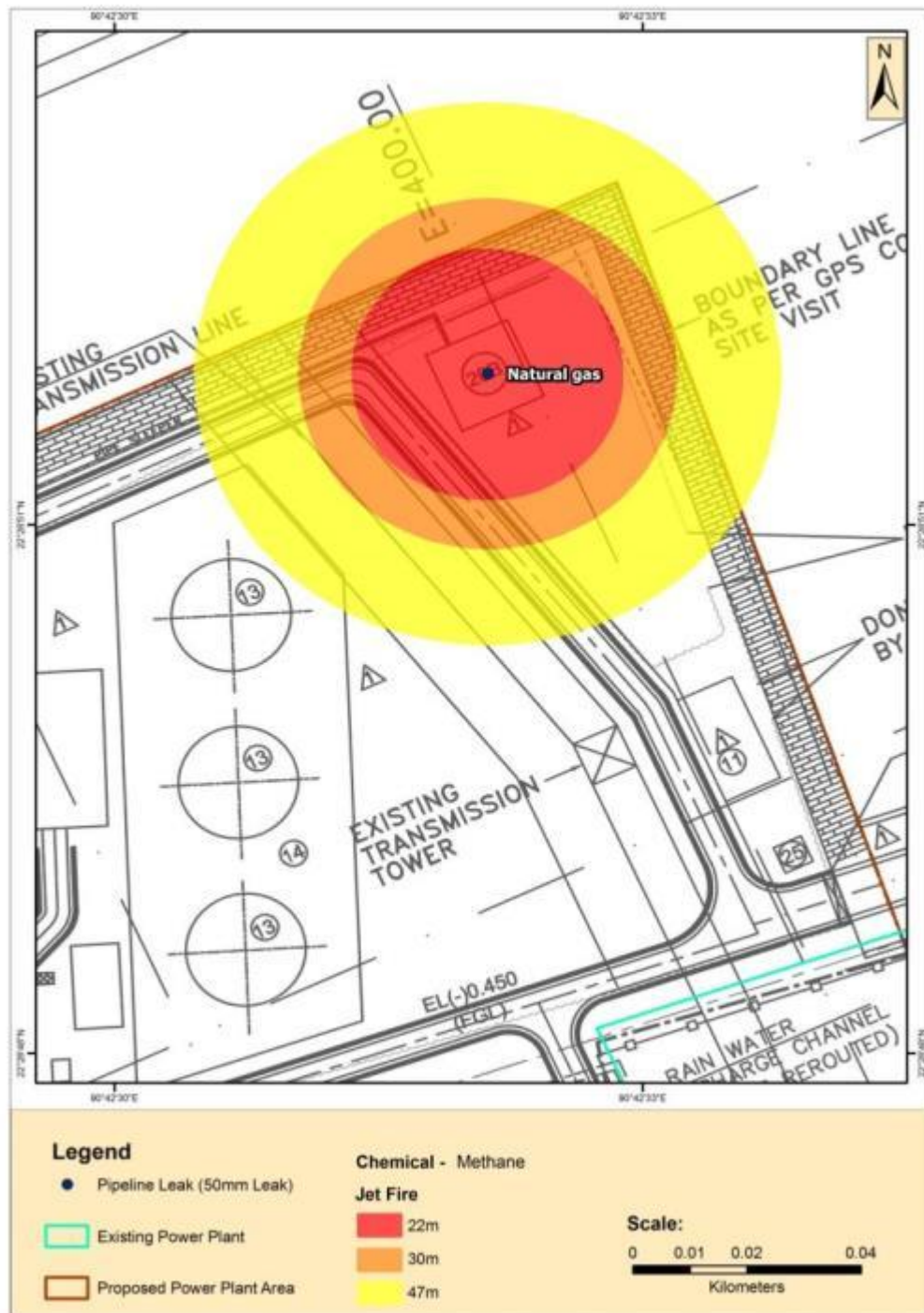
Yellow: 24 meters --- (2.0 kW/ (sq. m) = pain within 60 sec)

**The worst hazard for release and ignition of natural gas from the pipeline leak of 25mm dia will be experienced to a maximum radial distance of 11m from the source with potential lethal effects within 1 minute.**

*Scenario 2: Natural Gas Pipeline Leak (50mm dia)*

The jet fire threat zone plot for release and ignition of natural gas from pipeline leak of 50mm dia is represented in Figure 9.9 below.

Figure 9.9 Threat Zone Plot - Natural Gas Pipeline Leak (50mm dia)



Source: ALOHA

**THREAT ZONE:**

Threat Modeled: Thermal radiation from jet fire

Red : 22 meters --- (10.0 kW/ (sq. m) = potentially lethal within 60 sec)

Orange: 30 meters --- (5.0 kW/ (sq. m) = 2nd degree burns within 60 sec)

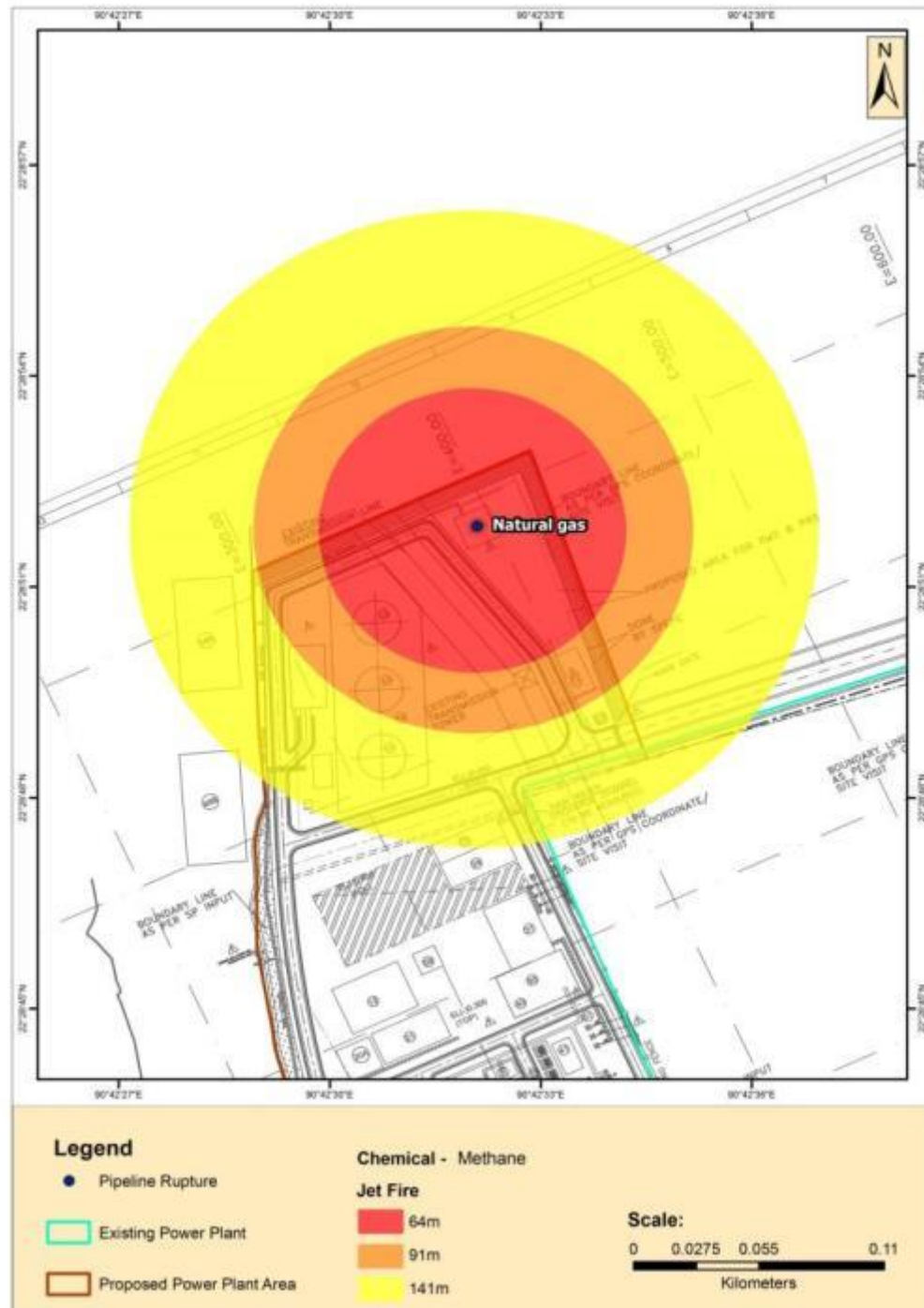
Yellow: 47 meters --- (2.0 kW/ (sq. m) = pain within 60 sec)

The worst hazard for release and ignition of natural gas from the pipeline leak of 50mm dia will be experienced to a maximum radial distance of 16m from the source with potential lethal effects within 1 minute.

*Scenario 3: Natural Gas Pipeline Rupture*

The jet fire threat zone plot for release and ignition of natural gas from pipeline rupture (worst case) is represented in Figure 9.10 below.

**Figure 9.10** *Threat Zone Plot - Natural Gas Pipeline Rupture*



Source: ALOHA

### THREAT ZONE:

Threat Modeled: Thermal radiation from jet fire

Red : 64 meters --- (10.0 kW/ (sq. m) = potentially lethal within 60 sec)

Orange: 91 meters --- (5.0 kW/ (sq. m) = 2nd degree burns within 60 sec)

Yellow: 141 meters --- (2.0 kW/ (sq. m) = pain within 60 sec)

**The worst hazard for release and ignition of natural gas from the pipeline rupture will be experienced to a maximum radial distance of 12m from the source with potential lethal effects within 1 minute.**

For VCE modelled for catastrophic failure of natural gas pipeline onsite, the LOC level was never exceeded

### THREAT ZONE:

Threat Modeled: Overpressure (blast force) from vapor cloud explosion

Type of Ignition: ignited by spark or flame

Level of Congestion: uncongested

Model Run: Heavy Gas

Red : LOC was never exceeded --- (8.0 psi = destruction of buildings)

Orange: LOC was never exceeded --- (3.5 psi = serious injury likely)

Yellow: LOC was never exceeded --- (1.0 psi = shatters glass)

For calculating the risk significance of natural gas pipeline, the likelihood ranking is considered to be "2" as the probability of pipeline rupture is computed to be  $\sim 4.1 \times 10^{-5}$  per year; whereas the consequence ranking has been identified to be as "4" as given for a worst case scenario (rupture) lethal effects is likely to be limited within a radial zone of  $\sim 64$ m. Also no social sensitivities in the form of village settlements, educational institutions etc. were found to be located within this zone. Further as discussed in the earlier section, adequate number of gas leak and fire detection system of appropriate design will be provided for the pipeline supply of natural gas to prevent for any major risk at an early stage of the incident.

*Risk Ranking – Natural Gas Pipeline Rupture (Worst Case Scenario)*

Likelihood ranking	2	Consequence ranking	3
Risk Ranking & Significance = 6 i.e. "Low" i.e. Risk is Acceptable and can be managed through use of existing controls and evaluation of additional controls.			

As discussed in *Section 9.8.2*, the release of chlorine from storage tanks can result due to corrosion, exothermic reaction, exposure to heat, failure of alarm devices/detectors etc. Generally chlorine is stored as a liquid under pressure in steel containers within a specifically designed enclosure equipped with various detection and safety devices. When a rupture or leak occurs in a liquid chlorine container, the sudden reduction in pressure that occurs causes a portion of the liquid to vaporise as it is released. The remaining liquid chlorine vaporised as it is warmed by the environment. When it becomes a vapour, liquid chlorine expands to 450 times the liquid volume. Consequently, a liquid chlorine release can affect a significantly greater than a chlorine gas release from a vessel or pipe with similar size hole. In all cases (depending upon the release volume), the incident will be a toxic vapour cloud moving downwind.

Chlorine released from process could result in significant consequences to the health of personnel within the affected areas due to its highly toxic nature. Taking into account the above tankage failure consequences and frequency analysis the following hypothetical risk scenarios (Refer Table 9.14) have been considered for risk modelling for chlorine release from tanks at the storage yard.

**Table 9.14 Chlorine Tonner – Risk Modelling Scenarios**

Scenario	Storage	Storage Diameter (m)	Storage Length (m)	Tank Volume (kg)	Accident Scenario
1	Chlorine Tonner	0.76	2.08	930 kg	5mm leak
2		0.76	2.08		10mm leak
3		0.76	2.08		Catastrophic Failure

For chlorine release from tonners, the LOC has been interpreted in terms of health effects on general public on exposure to specific concentration of chlorine expressed in terms of part per million (ppm). Based on review of the standard reference documents on chlorine - NIOSH, OSHA and Dangerous Materials Handbook by Irving Sax, the following threat zones have been considered for risk modelling of chlorine release from pipelines using ALOHA.

*Red: 20ppm – Dangerous to Life or Health (EPRG-3);*

*Orange: 3 ppm – Irritation to the mucous membrane of eye (EPRG-2); and*

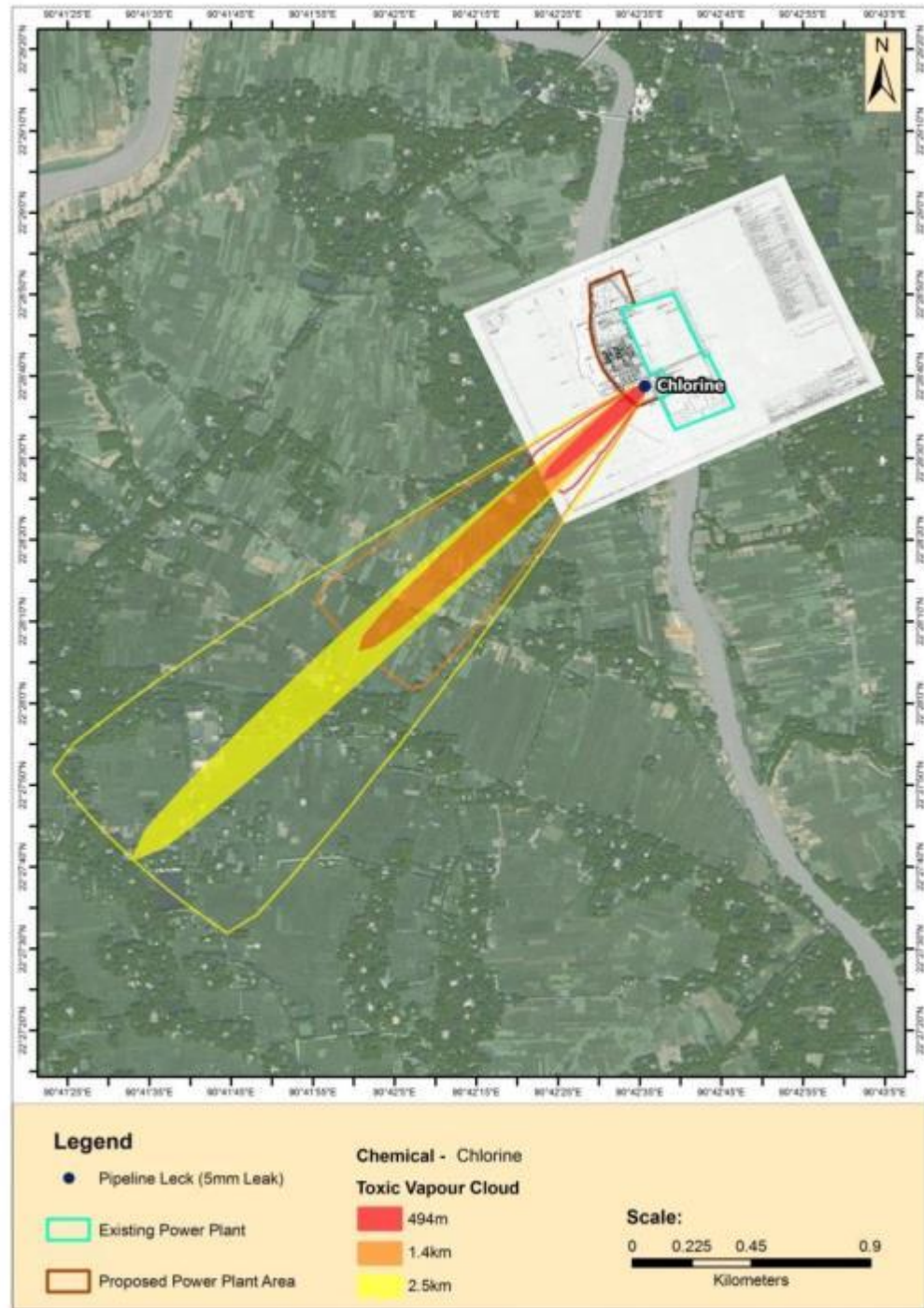
*Yellow: 1 ppm – Permissible Exposure Limit (PEL)/EPRG-1.*



Scenario 1: Chlorine Tonner leak (5mm dia)

The toxic vapour cloud threat zone plot for release of chlorine gas from leak (5mm dia) of chlorine tonner is represented in Table 9.11 below.

Figure 9.11 Threat Zone Plot- Chlorine Tonner Leak (5mm dia)



Source: ALOHA

## THREAT ZONE:

Threat Modeled: Toxic Vapour Release

Red : 494 meters --- 20 ppm = EPRG-3))

Orange: 1.4 kilometer --- 3 ppm = EPRG-2)

Yellow: 2.5 kilometer --- 1 ppm = PEL/EPRG-1)

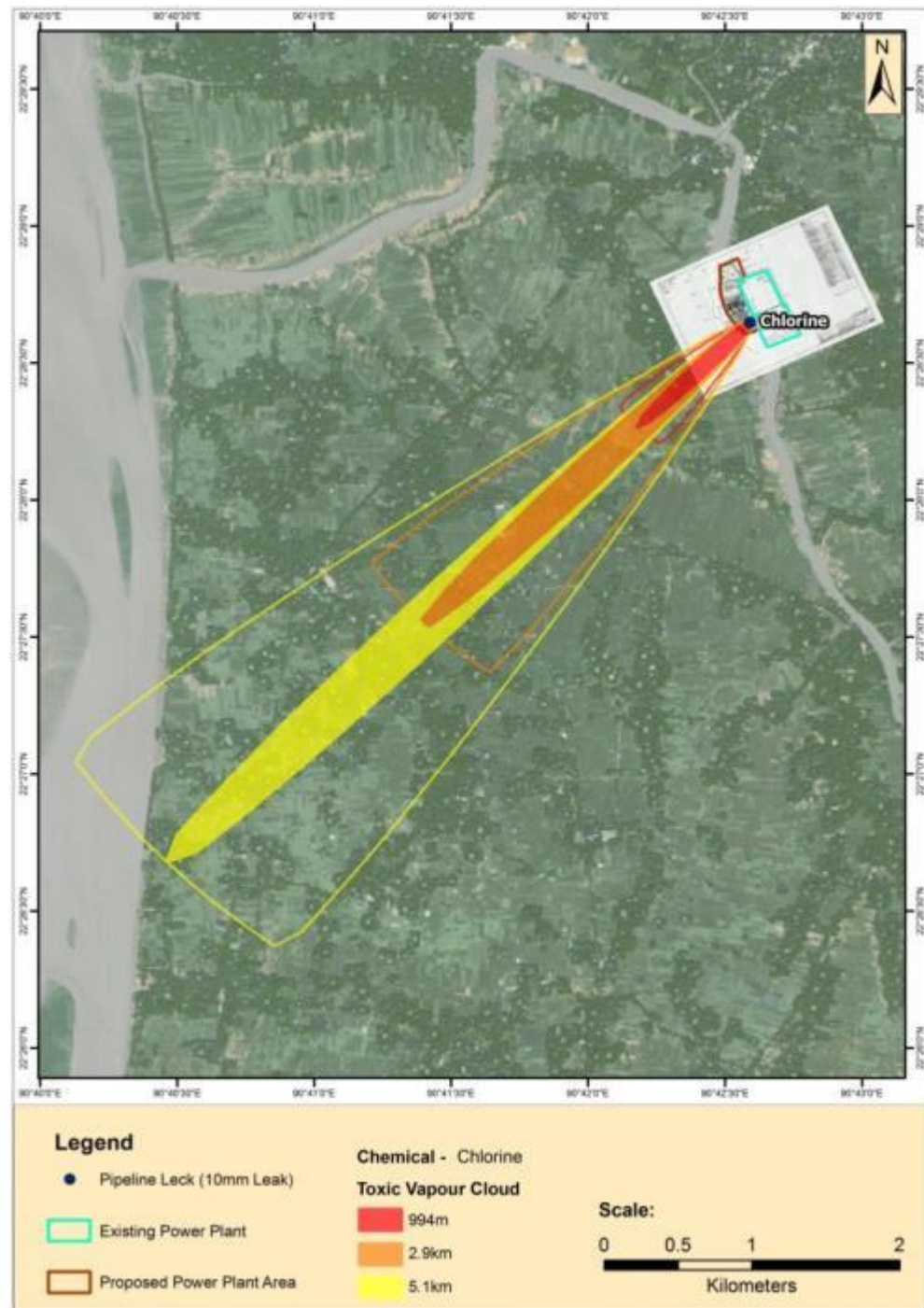
**The worst hazard for release of toxic chlorine vapour from 5mm leak of a chlorine tonner will be experienced within a radial distance of 494m from source . The total of mass of chlorine released for the scenario is computed to be 545 kg over a 60 minute duration .**

*Scenario 2: Chlorine Tonner Leak (10mm dia)*

The toxic vapour cloud threat zone plot for release of chlorine gas from leak (10mm dia) of chlorine tonner is represented in Figure 9.12 below.



Figure 9.12 Threat Zone Plot- Chlorine Tonner Leak (105mm dia)



Source: ALOHA

**THREAT ZONE:**

Threat Modeled: Toxic Vapour Release

Red : 994 meters --- 20 ppm = EPRG-3)

Orange: 2.9 kilometer --- 3 ppm = EPRG-2)

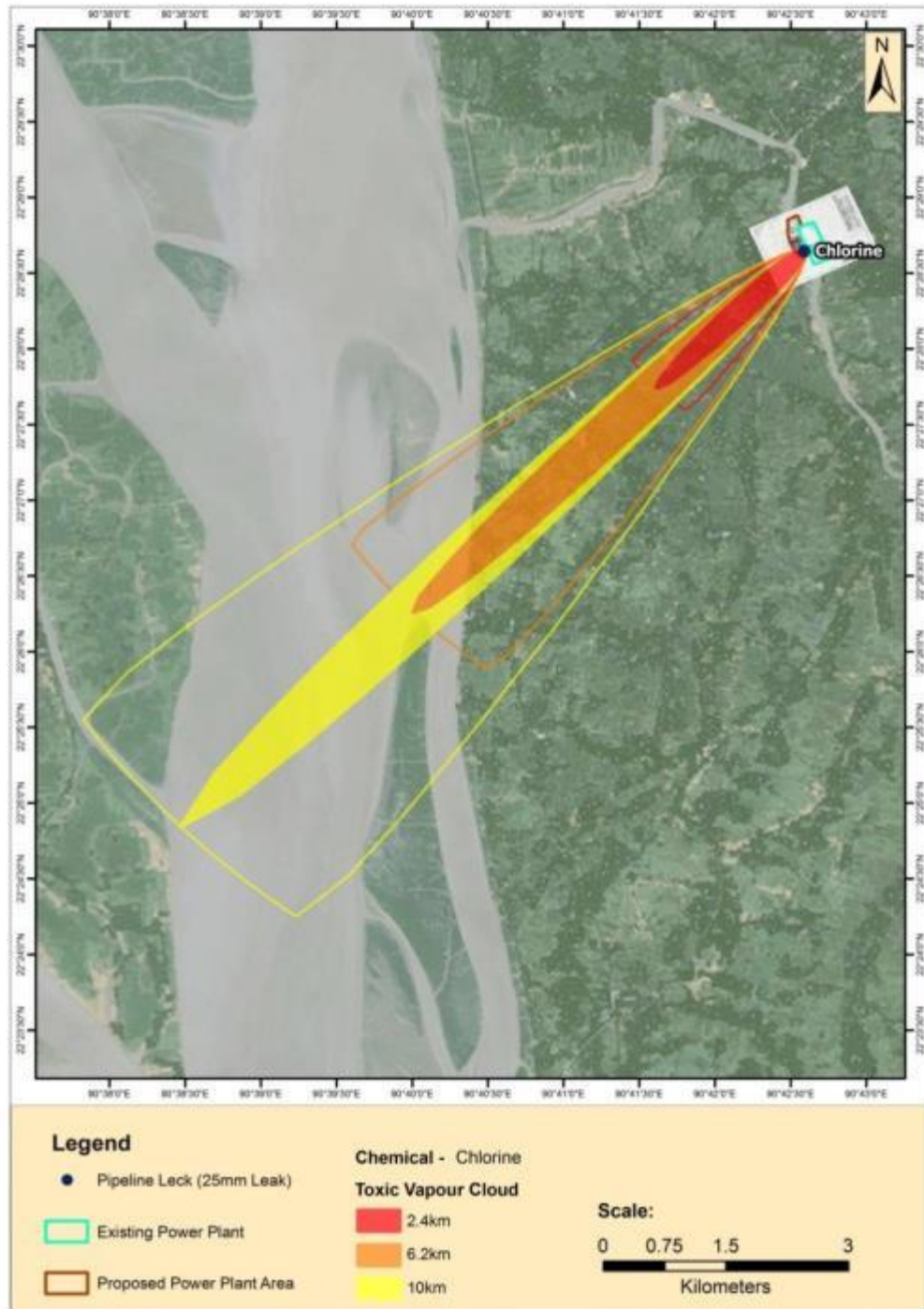
Yellow: 5.1 kilometer --- 1 ppm = PEL/EPRG-1)

The worst hazard for release of toxic chlorine vapour from 10mm leak of a chlorine tonner will be experienced within a radial distance of 994m from source. The total of mass of chlorine released for the scenario is computed to be 1177 kg over a 40 minute duration.

*Scenario 3: Chlorine Tonner – Catastrophic Failure*

The toxic vapour cloud threat zone plot for release of chlorine gas from a catastrophic failure of a chlorine tonner is represented in Figure 9.13 below.

**Figure 9.13** Threat Zone Plot-Catastrophic Failure of Chlorine Tonner



Source: ALOHA

## THREAT ZONE:

Threat Modeled: Toxic Vapour Release

Red : 2.4 kilometer --- 20 ppm = EPRG-3)

Orange: 6.2 kilometer --- 3 ppm = EPRG-2)

Yellow: 10 kilometer --- 1 ppm = PEL/EPRG-1)

**The worst hazard for release of toxic chlorine vapour from a catastrophic failure of a chlorine tonner will be experienced within a radial distance of 2.4km from source. The total of mass of chlorine released for the scenario is computed to be 1185 kg over a 7 minute duration.**

For calculating the risk significance of chlorine tonner failure, the likelihood ranking is considered to be "2" as the failure probability for such failure is computed to be  $\sim 4 \times 10^{-6}$  per year. As in With respect to consequence ranking, for the aforesaid incident it has been identified to be as "5" given for a worst case scenario a concentration of 20ppm will be manifested within a zone of 2.4 km from source. However appropriate mitigation measures and controls will be adopted by the site to both prevent and control any major risk associated with chlorine release at source.

### *Risk Ranking – Chlorine Tonner Failure (Worst Case Scenario)*

Likelihood ranking	2	Consequence ranking	5
Risk Ranking & Significance = 10 i.e. "Medium" i.e. Risk is Tolerable and can be managed through adoption of necessary controls.			

## 9.8 *RISK REDUCTION MEASURES*

The storage and handling of flammable and toxic chemicals at the site to be planned and designed so that they do not constitute any significant fire or explosion risks to people and properties within and surrounding the facility.

### 9.8.1 *Design Considerations*

In consistent with the aforesaid philosophy, SP INFRA will design the project in accordance to ASME, BIS and other relevant international standards. The plant operation and control will be achieved through a modern state-of-the-art control and instrumentation system employing DCS.

With respect to the fuel oil storage tanks, the firefighting facilities will be designed as per Oil Industry Safety Directorate (OISD) Standard 117. The storage and movement of fuels at the tank farm will be managed via combination of both manual and automatic tank gauging as specified in OISD-117. Product pump house, utilities and firefighting pumps will be in conformance to the OISD 118 standard requirement. All fuel storage tanks on site will be equipped with secondary containment in order to contain leaks and spills. Adequate number of gas leak detection and fire detection system as per stipulated norms will be provided for the pipeline supply of natural gas. For chlorine cylinders/tonners to be used, applicable regulatory provisions (as specified in the Bangladesh Pressure Vessel Rules, 1995) related to chlorine vessel design, its storage and handling will be complied with.

### 9.8.2 *Hazard Zone Classification*

Hazard zonation/classification of the site will be undertaken by SP INFRA in consistent with the requirements of the National Electrical code (NEC) and NFPA 497. As per NEC, there are three categories of the hazardous areas namely Class I, Class II and Class III. With respect to the respect to the proposed project, natural gas pipeline/metering station onsite to be classified as Class I hazardous area as flammable gas/vapour is involved. Diesel oil considered for this project is classified as Class-II as the flash point is expected to be a minimum of 35°C.

All electrical equipment installed in classified hazardous location is required to conform to the requirements of the international standard IEC 60079.

### 9.8.3 *Emergency Planning & Response*

For operations, the proponent will develop and implement a comprehensive Emergency Response Plan (ERP) in order to deal with both onsite and offsite emergencies. The overall objectives of ERP are summarized as follows:

- To establish and define roles of coordinators, plant key personnel & other emergency response personnel;
- To establish guidelines for effective response to any emergency;
- To contain and control emergency incidents;

- To prevent loss of life and minimize the risk of injuries to people working within the complex and neighbouring population;
- To minimize damage to company installations and public property & environment;
- To inform employees, public and authorities on the hazards/risks assessed, safeguards provided and the role to be played by SP INFRA; and
- Ensure a smooth interface between District Disaster Management Authority and Site Emergency Response Plan (ERP).

An Emergency Response Team (ERT) comprising of trained and qualified personnel will be constituted and will be in charge of the execution of the plan under the direct supervision of a Site Incident Commander. ERT will be responsible in periodically evaluating the performance of firefighting resources through reviews/inspections. Further, ERT will be conducting periodic mock drills to assess the overall preparedness of the facility in effectively responding to emergency scenarios.

#### 9.8.4 *Safety Management Measures for Operations*

##### *Toxic Gas Detectors (for Chlorine)*

Detectors for gases which create an immediate health hazard (danger to life) need to be placed at appropriate locations. The following applies to the selection of detectors in this category:

- detection shall be fast and reliable and preference shall be given to speed of response over precision;
- all aspects of HSE shall be included in the design study

Detection equipment shall be suitable for detecting the specific toxic gases or vapours that can be present in the area covered by the detectors.

The method for toxic gas detection shall be electrochemical except where:

- This is unsuitable (e.g. low humidity conditions where the electrochemical cell may dry out, or presence of interferences from other gases);
- Or other methods provide rapid detection (acoustic) of release events, or;
- Other emerging methods provide detection e.g. optical, or;
- Other methods are required by regulation.

Electrochemical sensor heads should not be installed until immediately prior to commissioning to avoid damage and poisoning of the sensor elements by construction activities such as painting, welding, freezing and mechanical impact. Care should also be taken in the case of electrochemical sensors, which have a very limited shelf life if left unpowered. Electrochemical sensors should be powered up within the time specified by the Manufacturer or delivery should be delayed until shortly before plant commissioning. For the sake of functional loop testing, a “sacrificial” head should be used to verify

that the transmitter is responding to test gas (i.e., move a single head from location to location).

Acoustic detectors SHALL [PS] be considered for detecting loss of containment of pressurised toxic gas where the release is into an open area and including elevated equipment, and where rapid response to loss of containment of pressurised gas is required.

#### Sensitivity

The minimum sensitivity of the detector should not be greater than 25 % of the high alarm concentration. The detector's concentration range maximum should be between 2x and 4x the highest alarm concentration. e.g. if the highest alarm level is 40 ppm, then the measurement range should be between 0-80 ppm and 0-160 ppm.

#### Manual Alarm Call (Electrical)

Manual Alarm Call devices SHALL [PS] be capable of being operated by simple operations e.g. lift flap and push button, or lift flap and pull handle, or break glass.

Local regulations may specify the type of action.

Manual Alarm Call devices shall be designed so it is visually obvious how the control works and if they have been activated. Further, their mode of operation shall be in compliance with the operator's cultural expectation for operation of emergency controls.

Where alarm call points possess a telephone (e.g. Gaitronics) a sound insulated booth shall be provided at the phone if the sound level exceeds 65 dB(A).

Manual Alarm Call devices shall be designed to avoid accidental activation.

Manual Alarm Call devices shall be sized to their expected mode of operation (for example, operators wearing heavy gloves or mittens).

#### Output

Simple Manual Alarm Call (e.g. switched) should have volt-free latching contacts for Alarm, and with end-of-line resistors for circuit monitoring via FGS analogue input modules.

Addressable Manual Alarm Call should be through discrete a protocol (e.g. Internet Protocol) for the system.

#### *Preventive Measures for Storage and Handling of HSD*

Fire is one of the major hazards, which can result from HSD storage tanks. The preventive measures include the following:

- Fire prevention and relevant code enforcement. The fire service facilities should be equipped with:
  - Smoke and fire detection alarm system.

- Water supply
  - Fire hydrant and nozzle installation
  - Foam system
  - Water for sprinkler system
  - Mobile fire fighting equipment
  - First aid appliances
- Periodical training/ awareness to be given to work force at the project site to handle any emergency situation;
  - Periodic mock drills to be conducted so as to check the alertness and efficiency and corresponding records should be maintained;
  - Signboards including emergency phone numbers and 'no smoking' signs should be installed at all appropriate locations;
  - Plant shall have adequate communication systems;
  - All major units / equipments should be provided with smoke / fire detection and alarm system;
  - 'No smoking zone' to be declared at all fire prone areas;
  - Sand buckets, fire hydrant points and fire extinguishers to be provided at strategic locations;
  - Storage location to be selected at an isolated place with proper fencing and guarding;
  - Co-ordination with local authorities such as fire, police, ambulance, district administration and nearby industries should be ensured to manage / control, meet any eventuality; and
  - Naked flame, welding etc to be not permitted in storage area.

*Preventive Measures for Handling of Natural Gas*

- Leak detection sensors to be located at areas prone to fire risk/ leakages;
- All safety and firefighting requirements as per OISD norms to be put in place;
- High temperature and high pressure alarm with auto-activation of water sprinklers as well as safety relief valve to be provided;
- Flame proof electrical fittings to be provided for the installation;
- Periodical training/awareness to be given to work force at the project site to handle any emergency situation;
- Periodic mock drills to be conducted so as to check the alertness and efficiency and corresponding records to be maintained;
- Signboards including emergency phone numbers and 'no smoking' signs should be installed at all appropriate locations;
- Plant shall have adequate communication system;
- Pipeline route/equipment should be provided with smoke / fire detection and alarm system. Fire alarm and firefighting facility commensurate with the storage should be provided at the unloading point;
- 'No smoking zone' to be declared at all fire prone areas. Non sparking tools should be used for any maintenance; and
- Wind socks to be installed to check the wind direction at the time of accident and accordingly persons may be diverted towards opposite direction of wind.



### *Preventing Fire and Explosion Hazards*

- Proper marking to be made for identification of locations of flammable storages;
- Provision of secondary containment system for all fuel and lubricating oil storages;
- Provision of fire and smoke detectors at potential sources of fire and smoke;
- Storing flammables away from ignition sources and oxidizing materials;
- Providing specific worker training in handling of flammable materials, and in fire prevention or suppression;
- Equipping facilities with fire detectors, alarm systems, and fire-fighting equipment;
- Fire and emergency alarm systems that are both audible and visible;
- For safety of people the building, regulations concerning fire safety to be followed. Some of the requirements include:
  - Installation of fire extinguishers all over the building;
  - Provision of water hydrants in operative condition;
  - Emergency exit;
  - Proper labelling of exit and place of fire protective system installation;
  - Conducting mock drills;
  - Trained personnel to use fire control systems.

### *General Health and Safety*

- The facility will adopt a total safety control system, which aims to prevent the probable accidents such as fire accidents or chemical spills.
- Fire fighting system, such as sprinklers system, portable extinguishers (such as CO<sub>2</sub>) and automated fire extinguishers shall be provided at strategic locations with a clear labelling of the extinguisher so the type of the extinguisher is easily identifiable. Also a main hydrant around the buildings will be available. On all floors an automated fire detection system will be in place.
- The site operations manager will take steps to train all emergency team members and shall draw up an action plan and identify members. The appointed emergency controller shall act as the in-charge at the site of the incident to control the entire operation.
- The staff shall be trained for first-aid and fire fighting procedures. The rescue team shall support the first-aid and fire fighting team.
- A first-aid medical centre will be onsite to stabilise the accident victim. The emergency team will make contact with a nearby hospital for further care, if required.
- A training and rehearsal of the emergency response by emergency team members and personnel on site will be done regularly.
- A safe assembly area will be identified and evacuation of the premises will be practised regularly through mock drills.
- In case an emergency is being declared, the situation shall be reported to the authorities such as local police, the chief inspector of factories and the state pollution control board as per rules and regulation of law of the land.

- Safety manual for storage and handling of Hazardous chemicals shall be prepared.
- All the personnel at the site shall be made aware about the hazardous substance stored and risk associated with them.
- Personnel engaged in handling of hazardous chemicals shall be trained to respond in an unlikely event of emergencies.
- A written process safety information document shall be compiled for general use and summary of it shall be circulated to concerned personnel.
- MSDS shall be made available and displayed at prominent places in the facility. The document compilation shall include an assessment of the hazards presented including (i) toxicity information (ii) permissible exposure limits. (iii) Physical data (iv) thermal and chemical stability data (v) reactivity data (vi) corrosivity data (vii) safe procedures in process.
- Safe work practices shall be developed to provide for the control of hazards during operation and maintenance
- In the material storage area, hazardous materials shall be stored based on their compatibility characteristics.
- Near miss and accident reporting system shall be followed and corrective measures shall be taken to avoid / minimize near miss incidents.
- Safety measures in the form of DO and Don't Do shall be displayed at strategic locations.
- Safety audits shall be conducted regularly.
- Fire fighting system shall be tested periodically for proper functioning.
- All hydrants, monitors and valves shall be visually inspected every month.
- Disaster Management Plan shall be prepared and available with concerned personnel department.

#### *Personal Protective Equipment*

In certain circumstances, personal protection of the individual maybe required as a supplement to other preventive action. It should not be regarded as a substitute for other control measures and must only be used in conjunction with substitution and elimination measures. PPEs must be appropriately selected individually fitted and workers trained in their correct use and maintenance. PPEs must be regularly checked and maintained to ensure that the worker is being protected.

#### *First Aid*

First aid procedures and facilities relevant to the needs of the particular workforce should be laid down and provided in consultation with an occupational physician or other health professional.

Health assessment should form a part of a comprehensive occupational health and safety strategy. Where employees have to undergo health assessment, there should be adequate consultation prior to the introduction of such program. Medical records should be kept confidential. Site should be able to relate employee health and illness data to exposure levels in the workplace.

This environmental and social impact assessment of the Nutan Bidyut (Bangladesh) Limited's (NBBL's) dual fuel (Natural Gas and High Speed Diesel Oil) based combined cycle power plant of net capacity of around 225 MW (the Project) has been prepared based on an understanding of the technical specifications available as of January 2017, existing studies and reports undertaken, a scoping exercise in April 2016 and subsequent site visits, stakeholder consultations, baseline environmental monitoring and socio-economic surveys which were undertaken between May 2016 to January 2017. The Project site is located within the area earmarked and developed for power generation by the Government of Bangladesh to utilise the natural gas availability in Bhola Island as well as to fulfil the objectives of PSMP.

Through this process an assessment has been done of the potential environmental and social impacts attributable to the construction and operation phases of the Project in line with the applicable environmental regulations in Bangladesh and international standards of ADB and the IFC. Environmental and social impacts during decommissioning of the Plant have not been considered in the impact assessment, as these will depend on the options available at the time of expiry of the power purchase agreement between NBBL and BPDB.

Qualitative and quantitative (where possible) assessments of impacts have been presented with an impact rating against each potential impact and mitigation measures to minimize and reduce the impacts. Cumulative environmental impacts particularly on water resources, air quality, greenhouse gases and noise have also been assessed taking into consideration overall development of the power generation complex in Bhola.

The environmental and social assessment of the Project ascertains that the Project is unlikely to cause any significant adverse environmental and social impacts. Many of the impacts are localised and short-term or temporary in nature and can be readily addressed by some embedded control measures in the engineering design of the Project as well as additional mitigation measures as suggested in the Environmental and Social Management Plan. The Project received favourable support from local people and other stakeholders during consultations undertaken for the study. Stakeholders appreciated that in addition to providing a reliable power supply to the region, the Project will have several other benefits such as supporting economic growth in the region by opening avenues for further development, employment (direct and indirect) and improving local infrastructure.

The stakeholder feedback and perceptions towards the project has also been influenced by the recent development (construction and operation) of BPDB's combined cycle power plant of Bhola I.

## 10.1 PROJECT IMPACTS

### 10.1.1 Pre-construction Impacts

Development of the Project will cause physical displacement of some households in the local communities of Kutuba and Kacchia Union (approximately 5 households). In addition, approximately 63 land owners and 25 land users have been economically displaced by the land requirement for the power plant. The right of way acquisition of the gas pipeline will additionally impact approximately 132 land owners and users, however, this impact will be limited due to the route of the pipeline being largely adjacent to the existing BPDB gas pipeline, thus minimizing land requirement. A Resettlement Framework has been prepared in order to implement mitigation measures to compensate the impacts of physical and economic displacement.

The Project study area is not having any ecologically protected areas. No archaeological or protected monuments are located in the Project vicinity. The nearest physical cultural resources (mosques and temples – excluding mosque within the power complex) of local importance are located over 500 m from the Project.

### 10.1.2 Construction Phase Impacts

During the construction phase of the Project, the key environmental issues are noise and dust generation. There is also a risk of contamination of soil, groundwater and the Dehular Khal from accidental spills and leaks of hazardous materials (e.g. oil) during handling, transportation, and storage at the site.

Various mitigation measures have already been developed by the Project Developer, as part of their “*Master Specification Manual*” for the EPC Contractor. The adverse impacts identified are generally manageable through good housekeeping and a diligent implementation of the ESMP by the EPC Contractor and its supervision by the Project Developer and their team of consultants. The nearest air quality and noise sensitive receptors will be a focus for monitoring of any impact arising due to the construction activities.

The social assessment of the Project ascertains that the Project is unlikely to cause any major social impacts during the construction phase. The adverse impacts are likely to be with respect to influx and in-migration into the project area and community health & safety. During the construction phase there will be impact from migration of labour into the Project area, construction activities and increased movement of traffic. The range of impacts identified include: conflicts with the local community, health and safety issues inconvenience due to vehicle movements, risk of spread of communicable and sexually transmitted diseases, waste disposal and unhygienic conditions. The magnitude and significance of most of these impacts would be limited to the construction period, with limited spill over to the operation phase.

As the project intends to have a construction camp outside the premises of the allotted land, the interaction between the community and migrant workers would require to be monitored. Furthermore, by implementing the recommended mitigation measures the Project will minimise the identified risks whereas on-going consultation and engagement will support the maintenance of a harmonious relation with the local community.

### 10.1.3 *Operations Phase Impacts*

During the operation phase of the Project, the two key impacts will be from the increase in ambient noise and air quality levels due to operation of plant equipment and auxiliary machinery. It has been demonstrated through air quality dispersion modelling with natural gas as primary fuel as well as HSD as secondary fuel, the incremental ground level concentrations due to the operation of the Plant will be well within the applicable ambient air quality standards. Continuous emission monitoring from the stacks and periodic ambient air quality monitoring throughout operations will confirm compliance to the applicable standards/ guidelines and enable identification of further measures to reduce impacts to ALARP. Incremental noise levels due to the operation of Plant will meet the applicable GOB standards/IFC guidelines for industrial areas. However, the nearest noise sensitive receptors will have slightly higher noise levels than the applicable standards/ guidelines due to the higher background noise levels which are resulted primarily due to anthropogenic activities.

Induced draft cooling towers have been proposed in the project to reduce the water intake and outfall. About 75 m<sup>3</sup>/hr of cooling tower blowdown and treated wastewater will be discharged into Dehular Khal. The cooling tower blowdown will maintain increase in temperature difference between intake and outfall water temperature < 3°C and due to that the warming of surface water will be limited to a smaller area at outfall location, which will mix within a short distance (< 50 m) from the outfall location. A surface water quality monitoring program, along with quarterly monitoring of aquatic ecology and fisheries has been formulated to further understand the extent of impact, if any, and to alert NBBL to take additional mitigation measures.

#### *Habitat Disturbance*

The project will entail loss of habitat and vegetation clearance during the construction phase due to dredging of Dehular Khal, dredging of sand and transport of material up to the project location and jetty development. During the construction and operations phase, accidental spillage of oil and chemical may lead to habitat disturbance. However, it has been assessed that this will not lead to a significant impact on aquatic ecology, fish resources and thereby fishing livelihoods and incomes.

NBBL will need to ensure that stakeholder engagement is undertaken to ascertain that access to fishing grounds and transportation by boats from Dehular Canal up to Tetulia river is not impacted. In addition, fish resources

and fish catch will need to be monitored through the construction and operations phase. For the latter, it is recommended that a thermal plume modelling is undertaken with focus on aquatic ecology and fishing implications by considering the inlet and outfall of BPDB and NBBL's water intake systems. Overall, the local community depends on Tetulia river for fishing and hence, while there is likely to be minor disturbance during construction, there is no significant disruption to fish resources and their availability.

#### *Local Community Benefits*

The project development of NBBL's power plant in addition to BPDB's existing power plant will enable local economic benefits linked to employment generation, local procurement, encouragement of local enterprise development and skill development within the communities.

The construction phase of the Project will have an important role in the socio-economic development of the area, whereas the operation phase of the Project will play an important role by supplying power in the region. A reliable and expanded power supply will support future economic development of dependant sectors including agriculture, industry and manufacturing enabling them to operate and compete.

In addition, by specific stakeholder engagement activities and community development programs, the Project will further enhance the good will and cooperation of the community. The Project in its entirety can bring prosperity and development into the region and pave the way for further industrialisation in sectors such as food and fish processing, local manufacturing etc.

## **10.2 OVERALL PROJECT CATEGORISATION**

To conclude, a majority of the environmental and social impacts are localised, short-term or temporary although some of them are permanent in nature like health associated risks due to air emissions and effluent release, but can be mitigated with appropriate mitigation measures built in as part of the Project planning process.

It is therefore established that the Project activities will trigger the ADB SPS Safeguard Requirement 1 and IFC Performance Standard 1 to 6 due to environmental and social impacts arising from the Project, trigger of negotiated settlement for the land procurement and right of way acquisition, involvement of about 1500 workers during construction phase (peak demand) and about 70 workers during operation phase and occupational health and safety (*PS2 – Labour and Working Conditions*); emissions, effluents and waste generation during the entire project life cycle (*SR1 – Environment and PS3 – Resource Efficiency and Pollution Prevention*) and community health and safety (*PS4 – Community Health, Safety and Security*) and presence of critical habitat to

a very limited extent (SR1 – Environment and PS6 – Biodiversity Conservation and Sustainable Management of Living Natural Resources) based on the assessment of the Project AOI.

However, PS 7 and 8 and SR – 3 will not be triggered, as the interactions between the baseline and the project development does not entail impacts to any indigenous community, their ancestral domain or rights and protected archaeological/ physical cultural site in the vicinity of the Project and its associated facilities.

### 10.3 ENVIRONMENTAL AND SOCIAL MANAGEMENT

The effective implementation of the ESMP and adherence with the GOB, ADB and IFC guidelines will assist in minimising the environmental impacts to acceptable levels. No additional studies for the ESIA are envisaged at this stage other than the proposed Resettlement Action Plan once the right of way for the pipeline is finalised as indicated in the Resettlement Framework.

Post environmental assessment, surveillance and monitoring are essential to track and sustain the effectiveness of the mitigation measures suggested. A detailed monitoring plan has been prepared as part of the EMP. The focus areas of monitoring cover air, surface water quality, groundwater quality, noise, soil erosion, soil and groundwater contamination, occupational health and safety as well as community health and safety. The reporting requirements along with the follow up actions in case of deviation from the norms have been detailed in the ESMP. The frequency has also been set in consideration of the likely impacts.

### 10.4 RESIDUAL IMPACTS

Table 10.1 present the outcomes of the comprehensive assessment of identified impacts as a result of various phase of the project and present significance of residual impacts before mitigation (with embedded controls) and with suggested mitigation measures.

Table 10.1 Summary of Impact Assessment and Residual Impacts

Project Activities/ Impacts	Nature of Impact	Significance of Residual Impacts	
		Before Mitigation	With Mitigation
<i>Construction Phase (NBBL Bhola-II Project)</i>			
Soil compaction	Negative	Negligible	Negligible
Soil erosion	Negative	Negligible	Negligible
Soil and sediment contamination	Negative	Minor	Negligible
Soil contamination from waste handling	Negative	Negligible	Negligible
Waste water discharge	Negative	Minor	Negligible
Ground water contamination	Negative	Minor	Negligible
Air quality degradation due to dust generation	Negative	Moderate	Minor
Air quality degradation due to exhaust emissions	Negative	Moderate	Minor



Project Activities/ Impacts	Nature of Impact	Significance of Residual Impacts	
		Before Mitigation	With Mitigation
Noise from Construction Activities and transportation of man/ material (Day-time)	Negative	Negligible to Minor	Negligible
Noise from Construction Activities and transportation of man/ material (Night-time)	Negative	Minor to Moderate	Negligible to Minor
Habitat Loss	Negative	Negligible to Minor	Negligible
Habitat Disturbance	Negative	Negligible to Minor	Negligible
Loss of land	Negative	Minor	Negligible
Fragmentation and Linear Impacts	Negative	Moderate	Minor
Physical displacement	Negative	Minor	Negligible
Economic displacement - impact on land owners	Negative	Minor	Negligible
Economic displacement - impact on land users	Negative	Moderate	Minor
Influx and in-migration	Negative	Moderate	Minor
Community health from changes in environmental conditions	Negative	Moderate	Minor
Local economy and skills development	Positive		
<b>Operation Phase (NBBL Bhola-II Project)</b>			
Contamination of soil and sediment from wastes	Negative	Negligible	Negligible
Surface water abstraction	Negative	Negligible	Negligible
Water pollution from wastewater discharge	Negative	Negligible	Negligible
Ground water contamination	Negative	Minor	Negligible
Ambient Air Quality (by use of natural gas as fuel for power generation)	Negative	Negligible	Negligible
Ambient Air Quality (by use of HSD as fuel for power generation)	Negative	Negligible	Negligible
GHG Emission due to Bhola-II project	Negative	Moderate	Moderate
Noise from Operation of Plant and vehicular movement in Access Road (Day-time)	Negative	Negligible to Minor	Negligible
Noise from Operation of Plant and vehicular movement in Access Road (Night-time)	Negative	Minor to Moderate	Minor
Electric and magnetic field	Negative	Minor	Negligible
Habitat Disturbance	Negative	Minor to Moderate	Minor
Risks due to hazardous materials handling and storage	Negative	Minor to Moderate	Minor
Community health and safety due to project induced traffic	Negative	Minor	Negligible
Risks of industrial accidents and fatalities to workers	Negative	Minor	Negligible
Impact on fishing communities	Negative	Minor	Negligible
Employment generation and in-migration of skilled workforce	Positive		
<b>Cumulative Impacts due to Operation of Bhola-I and II Projects)</b>			
Surface water abstraction	Negative	Negligible	Negligible
Water Pollution from Wastewater Discharge	Negative	Minor	Negligible
Ambient Air Quality (Cumulative impact due to Bhola-I and II projects) with natural gas as fuel	Negative	Negligible	Negligible
Ambient Air Quality (Cumulative impact due to Bhola-I project with natural gas and Bhola-II project with HSD as fuel)	Negative	Negligible	Negligible
GHG emissions due to Operation of Bhola-I and II Projects	Negative	Moderate	Moderate
Noise from Operation of Bhola-I and II projects (Day time)	Negative	Negligible to Minor	Negligible

Project Activities/ Impacts	Nature of Impact	Significance of Residual Impacts	
		Before Mitigation	With Mitigation
Noise from Operation of Bhola-I and II projects (Night time)	Negative	Minor to Moderate	Negligible to Minor

## 10.5

### CONCLUSION

Based on the analysis conducted in this environmental and social assessment, it is concluded that overall the Project will result in positive socio-economic benefits and the negative environmental impacts that have been identified are mostly short-term and localised in nature, and can be minimized adequately through good design, appropriate application of mitigation measures and regular supervision of implementation.

**ERM has over 160 offices  
Across the following  
countries worldwide**

Argentina	Netherlands
Australia	Peru
Belgium	Poland
Brazil	Portugal
China	Puerto Rico
France	Singapore
Germany	Spain
Hong Kong	Sweden
Hungary	Taiwan
India	Thailand
Indonesia	UK
Ireland	USA
Italy	Venezuela
Japan	Vietnam
Korea	
Malaysia	
Mexico	

**ERM India Private Limited**

Building 10, 4th Floor,  
Tower A, DLF Cyber City,  
Gurgaon NCR – 122 002  
India  
Tel : 91-124-4170300  
Fax: 91-124-4170301  
Email: india@erm.com

Regional Office – West  
801, 8th Floor, Windfall, Sahar Plaza,  
J B Nagar, Andheri (East),  
Mumbai – 400 059  
Tel : 022 42107373  
Fax: 91- 022- 4210 7474

Regional Office – West  
702 Abhishree Avenue,  
Near Nehru Nagar Circle,  
Ambawadi Ahmedabad -380006 India  
Tel: +91 79 66214300  
Fax: +91 79 66214301

Regional Office -South  
Ground Floor, Delta Block  
Sigma Soft Tech Park  
Whitefield, Main Road  
Bangalore- 560 066, India  
Tel: +91 80 49366 300 (Board)

Regional Office –East  
4th Floor,  
Asyst Park, GN-37/1, Sector-V,  
Salt Lake City, Kolkata 700 091  
Tel : 033-40450300

[www.erm.com](http://www.erm.com)